

Energy Efficient Automized Public Utility

Sachin Sanghratna Bhalerao¹, Professor :- Dr. Abhijit Banubakode²

^{1,2}Department of Computer Science, MET College, Bandra West

Abstract— This paper gives information to build a public utility. We use knowledge of PLC and SCADA. It is basically the delegation of human control function to the technical equipments for reducing energy consumption in terms of automatic control of Fan, Lighting system, Air conditioning system and Fire Alarm system, Water level control, Power distribution control system, emergency broadcasting and security automation. The best usage of electricity or saving of energy is one of the major concerns these days. Wastage of electricity cannot be avoided but can be minimized, if we efficiently use it. The same can be done if brains is added to the daily electrical appliances. Work of this brain is carried out by Programmable Logic Controller (PLC). Training of this brain is done by programming. The PLC is programmed using the ladder logic. The basic objective after using a PLC is that PLC has a capability of handling several Inputs, Output signals especially discrete. The overall automation of the Utility is controlled using SCADA software. SCADA is used to collect data from various Sensors and thus monitor the proper functioning of the plant.

Keywords: PLC; SCADA; PIR Sensor; Relay; Ladder Logic.

I. INTRODUCTION

This research deals with process of building automation. It is necessary to have a system solution which can turn operational excellence onto a permanent condition, ensure that system will work user friendly as well create the foundation for plant flexibility. Earlier the processes carried out in building automation were quite monotonous as a result the centralize control could not be possible. The centralize control in building automation as per the requirement is a chief necessity in building automation. The paper offers a hardware assembly for a building automation incorporating the use of PLC and SCADA which in turn results into improved efficiency, energy saving and cost effectiveness. The best usage of electricity or saving of energy is one of the major concerns these days. Wastage of electricity cannot be avoided but can be minimized, if we efficiently use it. The same can be done if brains is added to the daily electrical appliances. This paper deals with the Energy Efficient Automized Public Utility Building using PLC and SCADA. This approach is used for minimized the consumption of energy in terms of various electrical appliances.

The PLC is programmed using the ladder logic. The basic objective after using a PLC is that PLC has a capability of handling several Inputs, Output signals especially discrete which is very difficult in other

approaches. The overall automation of the Building is controlled using SCADA software. SCADA is used to collect data from various Sensors and thus monitor the proper functioning of the plant.

II. RELATED STUDY

Optimum usage of electricity or conservation of energy is one of the major concerns these days. Wastage of electricity cannot be avoided but can be minimized, if we efficiently use it. The same can be done if brains is added to the daily electrical appliances.

According to [1] describes the Energy Competent Building Automation and Control System using the concept of IEMN [3] characterized by its energy efficiency, which is able to minimize the use of overall energy consumption. Considering the environmental constraints, sensor provides a path for ECBAC.

The sensor based energy competent system is based on the fundamentals of usage and implementation of sensors along with the daily household devices which are very frequently used. The architecture design allows the implementation of an energy network monitoring and controlling systems which allows a user to access the appliances as per his desires and at the same time helps in saving the electrical power usage.

According to [2] the state of art and the major research challenges in architectures, algorithm, and protocols for wireless multimedia sensor network.

According to [3] Intelligent Energy Management Network for building automation describes an extension to the existing intelligent build network technology. The conventional intelligent building network facilitates the monitoring of sensor information and the issuing of controller commands by assuming that the network elements all have limited intelligence. The IEMN based on building automation and control network protocol and surrogate object-communication model to interconnect the building automation and control network, intranet and internet.

As per the [1] the architecture proposes that the usage of electricity per day consumption can be reduced that is the wastage of energy can be reduced by adding brains to the devices. With an example of a simple room where there are appliances such as Air Conditioner (A/C), bulbs and an automatic door. The following table shows the per hour energy consumption by the appliance in the present scenario:

TABLE I.

Component	Quantity	Per Hour Energy Consumed
Air Conditioner	1	1.335 KW
Bulb	1	0.1 KW
Automatic Door	1	0.35 KW

Energy Consumption by Different Electronic Appliance

TABLE II.

Simulation result of [1]

Component	Quantity	Daily Routine	Result of [1]
Air Conditioner	1	$1.335 \times 24 \times 1 = 32.04 \text{KW}$	$1.335 \times 0.5 \times 24 = 16.02 \text{KW}$
Bulb	4	$0.1 \times 4 \times 24 = 9.6 \text{KW}$	$0.1 \times 4.24 \times 0.25 = 2.4 \text{KW}$
Automatic Door	1	$0.35 \times 1 \times 10 \times 2 = 7 \text{KW}$	$0.35 \times 10 \times 2 \times 0.75 = 5.25 \text{KW}$
1 Room	-	48.64KW/day	23.67KW/day

According to their architecture, the number of bulbs active at a time results is 1/4 the number of bulbs which are active in a single room, so when the power supply is on 3/4 power of the total power is saved.

For the automation we are refers the various approaches, comparing the energy consumption table, the example of one room with some features like automatic door, A/C and bulb. In table 1 the energy consumption by different electronics appliances, the energy consumption per hour is shown. In the next table according to [1] this energy consumption is reduce as shown in table 2. For reducing this energy consumption the Zigbee sensors approach is used.

But this approach have some problem like mainly centralize control is not possible, also by using the Zigbee approach have low efficiency, and as use for large area like for college building it is costly because large number of Zigbee sensors are required which is turn to more costly, also Zigbee sensors are not compatible with atmospheric changes.

According to [2] in this approach architecture and algorithm is more complicated and controlling is not easily possible due to uneasy to understand algorithm. In the next approach [3] the intelligent building network facilitates the monitoring of sensor information and the issuing of controller commands by assuming that the network elements all have limited intelligence. In the earlier approaches problems mainly centralize control is not possible which is overcome by using the PLC and SCADA automation. So the aim of our project is to implement the knowledge of PLC and SCADA to build the real time automation for college building and try to reduce the energy consumption.

III. RESEARCH METHODOLOGY

A. PLC

PLC is stand for Programmable Logic Controller. A PLC is control system, designed for automation processes. It makes use of a programmable memory for the inner storage of user-orientated directions for imposing specific functions such as arithmetic, counting, logic, sequencing, and timing [5], [6]. A PLC can be programmed to sense, activate, and control industrial equipment and, therefore, incorporates a number of I/O points, which allow electrical signals to be interfaced. Input gadgets and output units of the system are related to the PLC and the control program is entered into the PLC memory.

PLC is computer based solid state device that controls equipments and process. Cost effective solution due to more number of input- output ports facility. Less labour charge as a process is automatic then there is a less requirement of labour. Human errors reduce, once a process is automatic and programming is over then chances of errors is negligible.

Programming of PLC is primarily based on the common sense requirement of input gadgets and the application implemented are predominantly logical rather than numerical computational algorithms. Most of the programmed operations work on a straightforward two-state "on or off" basis and these alternate possibilities correspond to "true or false" (logical form) and "1 or 0" (binary form), respectively. The programming method used is the ladder layout method. The PLC gadget affords a format environment in the shape of software tools jogging on a host laptop terminal which lets in ladder diagrams to be developed, verified, tested, and diagnosed[5].

B. SCADA

The term SCADA stands for Supervisory Control and Data Acquisition. A SCADA machine is a frequent technique automation device which is used to collect records from sensors and instruments positioned at far flung web sites and to transmit and display this data at a central website online for both manage or monitoring purposes. The accumulated records is usually seen on one or more SCADA Host computer systems located at the central or master site. SCADA basically consists of facts gaining access to function and controlling method remotely. SCADA refers to a gadget that collects records from various sensors at a building, factory, Plant or in other remote places and then sends this data to a central computer which then manages and controls the data.

SCADA is a large scale control system for automated process. SCADA is nothing however the graphical illustration of automation. SCADA systems are used to control and monitor the physical process and make online changes whenever required[5],[7]. Previously

without SCADA the process was entirely controlled by PLC, PID & micro controllers having programmed in certain languages or codes. These codes were written in assembly language without any true animation. So it is difficult to understand, but using SCADA we can easily understand the process if it is shown with some animation rather than written codes.

Many industrial and infrastructure-scale businesses depend on tools located at more than one sites dispersed over a large geographical area. A significant majority of large infrastructure and industrial-scale ventures use Supervisory Control and Data Acquisition (SCADA) systems.

IV. BLOCK DIAGRAM

This block diagram gives the example of one room with basic feature like lighting control, this deals with the key components used in the process and thus explains the use and working of each component. The block diagram of the experimental set up is illustrated. The following configurations can be obtained.

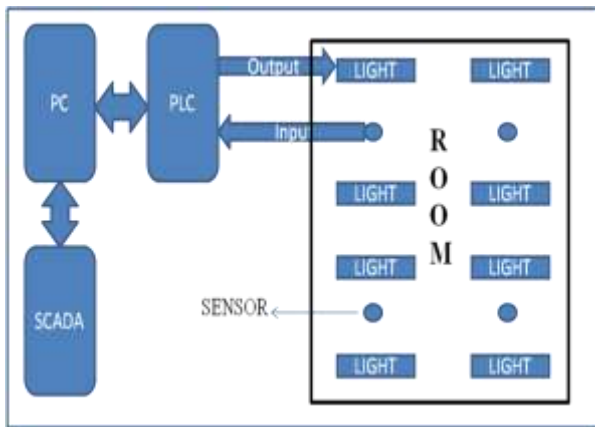

Figure I Block Diagram

The digital computer is used as an interface between PLC and SCADA. The PLC is a micro processor based system controller used to sense, activate and control equipments and thus incorporate a number of input output/modules which allows electrical system to be interfaced. SCADA is a centralized machine used to supervise a complete plant and essentially consists of records gaining access to elements and controlling approaches remotely. The conversation protocol used is Ethernet.

The sensor is PIR Motion detector sensor use to detect the motion of live object. The room with basic function like light manipulate system.

V. PLC AND RELATED SOFTWARE

The PLC is MicroLogix 1400 as it has 20 inputs and 12 outputs and has an interface for Ethernet. The MicroLogix 1400 system offers higher I/O count, faster high-speed counter, and enhanced network capabilities,

the programming software is RSLOGIX 500, Ladder logic based programming and the communication software used is RS LINX 500. Expandable DI cards is MicroLogix 32 Point Digital Input Module, Expandable DO cards is MicroLogix 32 Point Digital Output Module.

A. Feature of MicroLogix 1400

Ethernet port presents Web server capability, email capability and protocol support.

Built-in LCD with backlight lets you view controller and I/O status.

Built-in LCD presents simple interface for messages, bit/integer monitoring and manipulation.

Expand application capabilities through support for as many as seven 1762 MicroLogix Expansion I/O modules with 256 discrete I/O.

The sensor is PIR (Passive infrared sensor) motion detector sensor. Which is use to observe the movement of stay object. A passive infrared sensor (PIR sensor) is an digital sensor that measures infrared (IR) light radiating from objects in its discipline of view. They are most frequently used in PIR-based motion detectors. A PIR-based motion detector is used to sense movement of people or animals. The Input voltage 9-16V DC, 12mA and Output voltage 12V DC.

VI. PROCESS FLOW

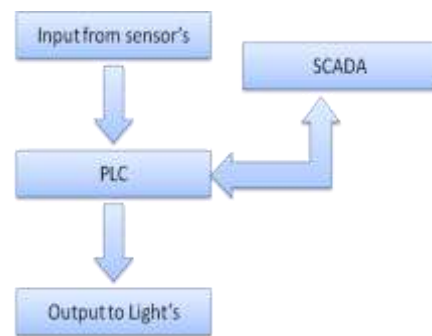

Figure II. Process flow

To start the process the PIR motion detector sensor is placed in to the room. When PIR motion detector sensor sense the motion of human body then it gives the high output. This high bit is given to the PLC. The PLC in turn offers a sign to the inverter to begin the lights. Corresponding lights is start in the region where the sensor is placed. The lights is ON till the sensor sense the motion in the unique region, if there is no motion in to the corresponding vicinity then the sensor offers low output. This low bit is given to the PLC. The PLC in turn gives a signal to the inverter to OFF the lights into the corresponding region.

The SCADA is installed in the computer and through serial port it is linked with PLC. All the area units are

linked to PLC and they get alerts from PLC. Whatever applications we prefer to run can be carried out either via PLC or SCADA.

Figure III shows the development window of SCADA. In this window we can develop one room with primary function like lightning and fan manage system. In improvement window we are given the symbol from the wizards and write script for that symbol. In the initial window there is a light, the condition of light is like when light is OFF it indicates with Red coloration and when the light is ON then it indicates with Green colour. For centralized control there is a switch placed in the SCADA window. The one room is divided into four regions that are region A, region B, region C and region D. In each region a sensor is placed.

Diagram IV indicates the run time window of SCADA. As we can see in diagram IV the person enters into the room at the same time entrance light is turned ON as shown by Green colour light. This entrance light is turned ON till the other light in the room is not ON. When any other light in the room is turned ON, then entrance light is automatically turned OFF.

Diagram V indicates some other run time window of SCADA. As we can see in diagram V the man and woman enter into the vicinity A, the corresponding Lights and Fans are turned ON as light shown by green colour. And the entrance light is turned OFF. The light in the region A is turned ON till the person covers the region A, after leaving the region A the corresponding Lights and Fans in that region are turned OFF.

Figure VI. SCADA Run time window

Diagram VI shows another run time window of SCADA. As we can see in figure VI there are two persons sitting in two different regions that are in region B and region D the corresponding lights and fans in that region are turned ON as shown via green colour lights. And the remaining lights and fans in the room are turned OFF. That means when a person is present in a particular region then and only then the corresponding lights and fans in that region are turned ON otherwise they are OFF. In this way the energy consumption is reduced.

VII. CONCLUSION

In this paper we conclude the overall process offers a hardware assembly for a building automation that incorporates the use of PLC and SCADA which in turn results into improved efficiency, cost effectiveness and energy saving. On the problem of energy consumption we have a system solution which is turn operational excellence onto the permanent condition, ensuring that the system is work user friendly as well as created the foundation for plant flexibility. The chief necessity of centralized control is achieved by SCADA and PLC approach. Reducing the energy consumption in terms of lightning control system and Fan Control system is achieved.

REFERENCES

- [1] Shipra Kapoor, Darshan Taneja, Vaibhav Malhotra "Energy Competent Building Automation and Control System" UACEE International Journal of Advance Electronics Engineering Vol.2: Issue 3 ISSN 2278-215X.
- I.F. Akyildiz, T. Melodia, K.R. Chowdhury "Wireless Multimedia Sensor Networks: A Survey" IEEE wireless communication 51 (4) 1536-1284, Dec. 2007.
- Hsiao-Yi Huang, Jia-Yush Yen, Member, IEEE, Sih-Li Chen, and Feng-Chu Ou, "Development of an Intelligent
- K.F. Tsang, Member, IEEE, KL Lam and HY Tung "Energy Management Using Zigbee" IEEE Third International Conference on Next Generation Mobile Applications, Services and Technologies 978-0-7695-3786-3/09, 2009.
- Ioan Valentin Sita "Building Control, Monitoring, Safety and Security using Collaborative Systems" IEEE Fourth International Conference on Intelligent Networking and Collaborative Systems 978-0-7695-4808-1/12, 2012.
- JiLi, Yue Zhang* "Intelligent Building Automation and Control Based on IndasIBMS Title" 2013 International Conference on Service Science, Apr-2013.