

Design and Analysis Report of a Professional Go-Kart

Aditya Pawar¹, Kishan Patel², Sai Upamanyu³, Prithvi Bhagat⁴, Himarohith Reddy⁵,
U Jatin Aneesh⁶

^{1,2,3,4}Students, Department of Mechanical Engineering, Symbiosis Institute of Technology, Pune, India

Abstract - Karting is commonly perceived as the stepping stone to formula one car. Go-kart is rear wheel IC engine driven automobile without any suspension and differential. The main objective of the design is to make a kart that is light in weight and performance packed. This paper explains the parameters included in the designing, fabrication and analysis of a kart. The paper also includes the designing of kart with better ergonomics for driver. The flexural rigidity of the structure and deformation of chassis are observed and compared between materials. Modeling of frame has been carried out in Solid works software, the validation was obtained by using Ansys Workbench 18.2 student, fabrication using various manufacturing processes in workshop in compliance with the rulebook of INDKC 3rd Edition which is necessary and governs a significant portion of the objectives. The paper is intended to help under graduates by giving a neat overview from initial to final stage in terms of design and fabrication of go-kart to participate in upcoming national competitions.

Keywords - Go kart, design, lightweight, ergonomics, FEA performance packed, Solid works, Ansys 18.2 workbench.

1. INTRODUCTION

The go kart has been designed and manufactured by team 'Wrench Welders Racing' consisting of under graduates of Symbiosis Institute of Technology affiliated to Symbiosis International University (Deemed), Pune, Maharashtra. The team was formed in 2016 and has participated in various national wide kart racing championships. Go-Kart is an open wheeled vehicle which is simple, lightweight, compact and easy to operate. It can be made and driven by a professional or a non-professional. The go-kart is specially designed for racing and recreational activities. Go karting being the initial prerequisite to F-1 racing, which is evolving motorsport in India which soon would be driven by upcoming enthusiasts.

Go karts are usually powered by two-stroke or four strokes. The common parts of a go-kart include the engine which is the drive for the vehicle, wheels that help in steering along with steering system, transmission consists of gear link, rear axle shaft on which braking system is linked to it. We have approached our design by considering all possible alternatives for a system & modelling them in CAD software like Solid Works and subjected to analysis using ANSYS FEA software. Based on

analysis results, the model was iterated and retested and the best design was finalised. The design process of the vehicle is based on various engineering processes depending upon the availability, cost and various other factors.

Thus, the design process focuses on following objectives: safety, serviceability, strength, and ruggedness, cost effectiveness, driving comfort, aesthetics and ergonomics. Analysis is conducted on all major components to optimize strength and rigidity, improve vehicle performance and reduce complexity and manufacturing cost.

Different manufacturing processes were used to manufacture different parts, like

- Welding (MIG & Arc welding) - Brake calliper mounting, steering mounting.
- Laser cutting - steering hub, tripod arm, rear wheel bearing support.
- Turing (Lathe) -steering Hub, knuckle, steering column, tie-rod, shaft.
- CNC- wheel hub, brake hub.
- Grinding (Angle, Pencil & Bench)- steering components, Frame members.
- Drilling (portable hand drill, radial machine drill)- steering components, Frame members, mounting members, seat mounting etc.

2. TECHNICAL SPECIFICATIONS OF THE KART

Table -1: KART SPECIFICATIONS

Engine	
Engine	Bajaj Discover 125 DTSi
Max. Torque	10.8 Nm at 6000 RPM
Max. Power	11.5 PS at 8000 RPM
Max. speed of bike	110 kmph
Kart Performance	
Max. Speed	80 kmph
Maximum torque at rear axle	50 Nm
Diameter of Shaft	30mm
Chassis	
Chassis weight	22 kg
Total weight with fluids	95 kg
Material	AISI 1018 (pipe)

Pipe Dimension	OD- 31.75 mm, Thickness - 2 mm
Kart Dimensions	
Wheelbase	1030 mm
Track-width	Front - 1020 mm, Rear - 1150 mm
Track-width to Wheelbase ratio	111.50%
Length of Kart	1738 mm
Width of kart	1182 mm
Height of Kart	650 mm
Steering	
Minimum turning radius	2000 mm
Ackerman angle	22 degree
Caster angle	5 degree
Kingpin inclination	10 degree
Camber	0
Transmission	
Chain Type	Roller Chain
Chain number	40
Chain Pitch	1/2 inch
Brakes	
Brake Type	Hydraulic Disc Brake
Brake Material	SS 304
Disc Diameter	170 mm
Master Cylinder Diameter	10 mm
Disc Thickness	4 mm



Fig- 2: ISOMETRIC VIEW 2



Fig- 3: ISOMETRIC VIEW 3

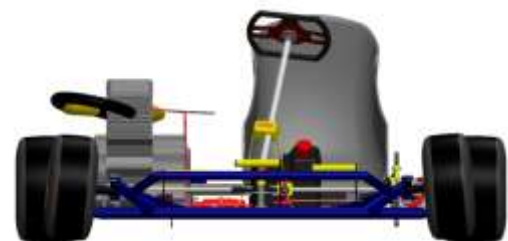

Fig- 4: FRONT VIEW

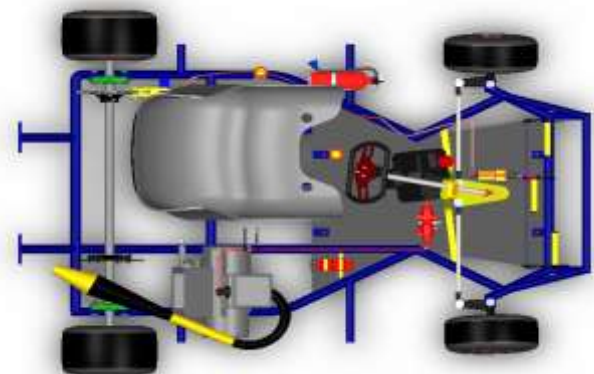

Fig-5: TOP VIEW

3. 3D VIEWS OF THE KART

The fig. 1-9 give a clear picture of the kart seen from different views and angles in CAD software.



Fig-1: ISOMETRIC VIEW 1



Fig-6: REAR VIEW



Fig-7: LEFT VIEW



Fig-8: RIGHT VIEW

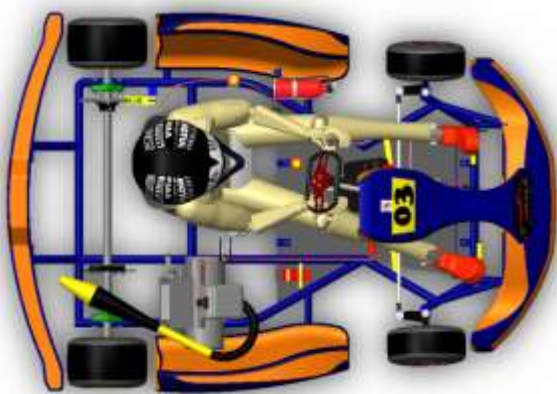

Fig-9: TOP VIEW

4. DESIGN METHODOLOGY

4.1 ERGONOMICS CONSIDERATIONS

In an automotive context, ergonomics is the design process that takes into accounts the driver's abilities, specific work processes and comfort. It is vital, therefore,

that the cockpit of an automobile be designed to maximize driver performance. In our case, the driver has to be supported in healthful postures to operate the controls, see what he needs to see and be well positioned for the safety restraint systems to work. As we can see from the below figure about the driver position while driving the kart. The seat positioning and dimensioning is done in such a way that the driver of the kart drives comfortably and efficiently. The positioning has to be optimum to get efficiency.

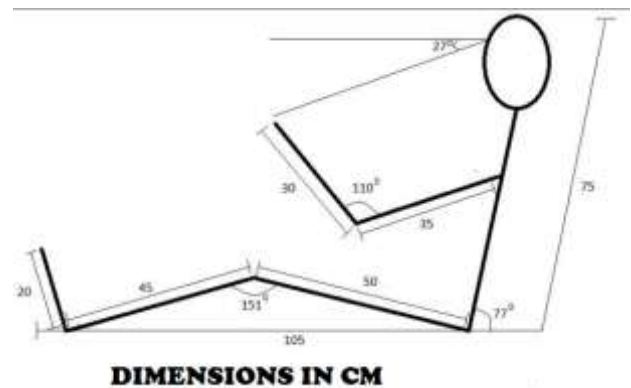

Fig-10: HUMAN STICK DIAGRAM

4.2 FLOOR PLANNING

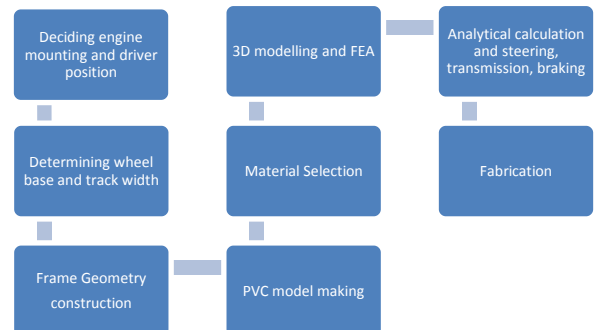

Fig-11: DESIGN METHODOLOGY

According to fig. 11, the flowchart shows the strategic planning from designing the geometry of the kart to the fabrication.

4.3 FRAME DESIGN

Usually the trackwidth to wheel base ratio is not allowed below 0.7 or 70% in rulebooks of national competitions held in India. It is optimum to keep the ratio between 0.8 to 0.9 or 80% to 90%. This could also depend on how much the driver prefers to keep his or her work range envelope. First step is to decide if the kart would be side mounted or rear mounted.

Side mounted engine karts are usually preferred by professionals because it leads to acquire a shorter turning radius and better manoeuvrability in dynamic tests of as it takes less space and is easier to stay in narrow tracks throughout the turn. In this method, the engine is placed on the outer most edge of side chassis member to avail maximum space for driver seating. Only care should be taken that the engine should lie well inside the side bumper outer edge which is prohibited. In this approach, the driver seat should be as close as possible to centre axis to maintain the CG at the centre most.

While the rear mounted engine method is an easy to manufacture and systematic approach which divides the go kart in two sections i.e. the driver cockpit and transmission. Entire steering assembly, pedal box, driver seat, fire extinguisher falls under cockpit section. Whereas rear axle shaft, chain and sprocket, brake disk and calliper, engine and electrical harnesses fall under the transmission section. This helps the designers to visualize the manufacturing in suitably planned manner. This method is usually followed by the beginner teams and is a recommended approach for neophytes. Being rear mounted, the go kart needs additional momentum to achieve the desirable yaw movement or a drift when oversteering the go kart which is not easily achieved at low speed. Due to the increased length, the driver also could find difficulty to slip through the narrow turns easily in various dynamic tests. To reduce the wheel base designers, place the engine above the shaft to form a vertical chain sprocket transmission. This method could face few problems such as the space constraints for chain under the driving sprocket of engine which could be overcome by chain tensioner or changing driving sprocket.

The frame has been designed to maintain rigidity and support all the sub systems of the kart such that it should handle all the components including driver safety and comfortably. Circular pipes are best suited because of few reasons such as uniform stress distribution, minimum crimp during bending, easy to notch. All the members of the frame work are hollow with certain radius of bends. The engine has been mounted on the right side of the driver.

Table- 2: FRAME PARAMETERS

Chassis	
Frame weight	8.5kg
Total weight with fluids	95kg
Material	AISI 1018
Type	Circular Cross Section
Pipe Dimension	OD- 31.75mm Thickness - 2mm

4.4 CAD MODEL IMAGES OF FRAME



Fig- 12: ISOMETRIC VIEW OF FRAME

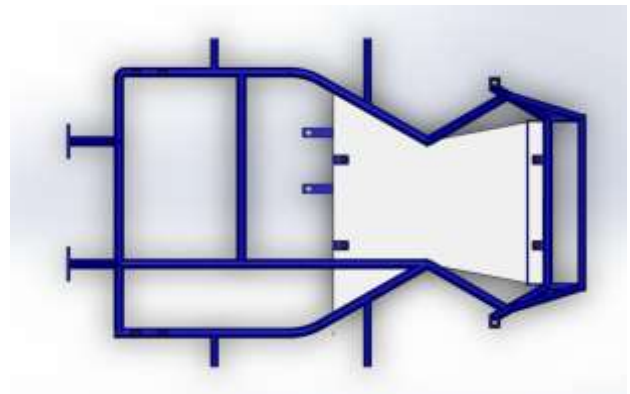

Fig-13: TOP VIEW OF THE FRAME

5. MATERIAL SELECTION

While selecting the pipe material, it is more appropriate to compare the ratio of strength to cost per meter amongst the material for selection. It is a more economical way for selection. The selection of material for chassis was done by detailed study of properties of 4 materials which were AISI 1018, AISI 1020, AISI 4130, AISI 1026 regarding their strength ,rigidity ,strength to weight ratio, chemical properties, mechanical properties, manufacturability, cost, special characteristics and the results suggest that the material AISI 1018 is suitable and economical for building the Go-kart.

The material AISI-1018 was used by us in the chassis design because of its good weld ability, relatively soft and strengthens as well as good manufacturability. AISI 1018 can satisfies this need successfully.

Table-3: MATERIAL PROPERTIES

MECHANICAL PROPERTIES	AISI 1020	AISI 1018	AISI 4130	AISI 1026
DENSITY (gm/cc)	7.87	7.87	8	7.87
TENSILE STRENGTH (MPa)	420	440	440	435

YIELD STRENGTH (MPa)	350	370	365	335
MODULUS OF ELASTICITY (GPa)	205	205	205	200
ELONGATION IN BREAK (50mm)	15%	15%	25%	20%
STRENGTH TO WEIGHT RATIO(KN-m/kg)	55	60	60	45
ROCKWELL HARDNESS	68	71	70	68
THERMAL CONDUCTIVITY	51.9	51.9	49.8	50.2

We can see from the above table that AISI 1018 has the best suitable mechanical properties. AISI 1018 has the ideal chemical properties too. After the analysis as shown in table 3, the material was finalised and used for the manufacturing of the Go-kart chassis.

6. DESIGN DECISIONS & JUSTIFICATIONS

To make the kart efficient and optimum, there were certain design decisions taken. Round and hollow pipes are used for the chassis to make it light weight. These were holes made on unnecessary bulk parts for weight reduction. The kart chassis weighs 8.5kgs which is pretty light weight compared to an average kart. Even though fuel tank is placed under the steering rod, it is seen that the positioning is in a way that doesn't create any discomfort to the driver. The kart is very spacious compared to a general kart making it easy for the driver to sit comfortably and more than enough space is provided for steering turning. This prevents the kart to go out of control in high speed situations.

7. FINITE ELEMENT ANALYSIS

To check the safety of our kart we have used FEA analysis in ANSYS 18.2 student. Finite element analysis (FEA) is a computerised method for predicting how a product reacts to real-world forces, vibration, heat, fluid flow and other physical effects. Finite element analysis shows whether a product will break, wear out or work the way it was designed. It is called analysis, but in the product development process, it predicts what's going to happen when the product is used. We have aimed for safety, performance and aesthetic as our highest priorities, the main and most important aspect is safety of the design as it is the one of the main aspects.

7.1 MESHING

As shown in fig. 14, hexagonal meshing and adaptive was done in ANSYS 18.2 software. Following data has been

found after meshing the frame at element size of 1mm. No. of nodes = 205488; No. of elements = 103925

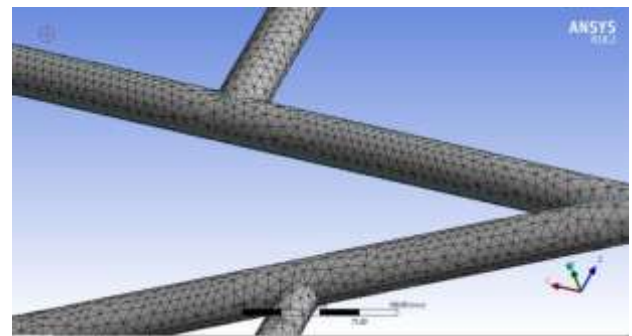

Fig- 14: MESH SIZE

The boundary condition for the impact was done by constraining the king pin and the rear axle mounting.

7.2 FRONT IMPACT

Force of 3g (3*9.81*120kg) i.e. 3530 N was applied on the front most member of the frame in fig. 15 and fig. 16.

The FOS was found to be 1.29.

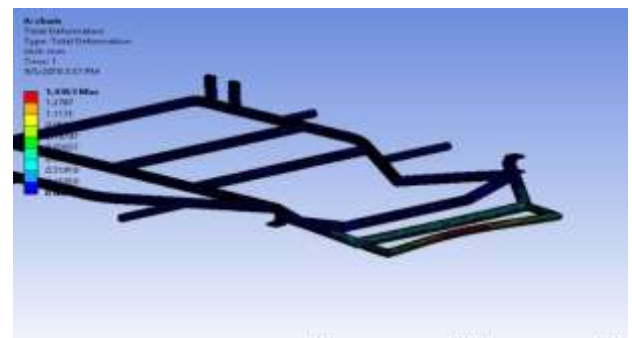

Fig- 15: FRONT IMPACT, DEFORMATION

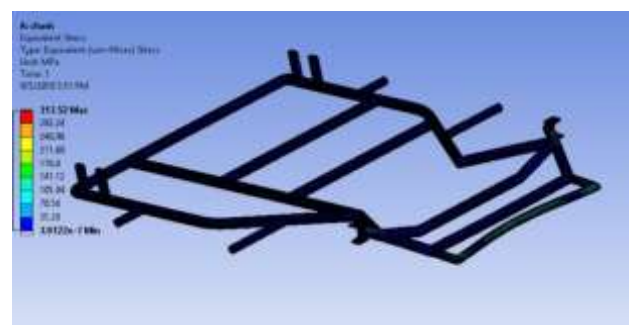

Fig- 16: FRONT IMPACT, STRESS ANALYSIS

7.3 REAR IMPACT

Force of 3g was applied on the rear most member of the frame and deformation in fig. 17 and fig. 18, The FOS was found to be 1.25.



Fig- 17: REAR IMPACT, DEFORMATION



Fig- 18: REAR IMPACT STRESS ANALYSIS

7.4 SIDE IMPACT (RIGHT)

Force of 3g ($2 \times 9.81 \times 120\text{kg}$) i.e. 3530 N was applied on the right side most member of the frame and deformation, stresses and FOS were calculated in fig. 19 and fig. 20. The FOS was 2.4.

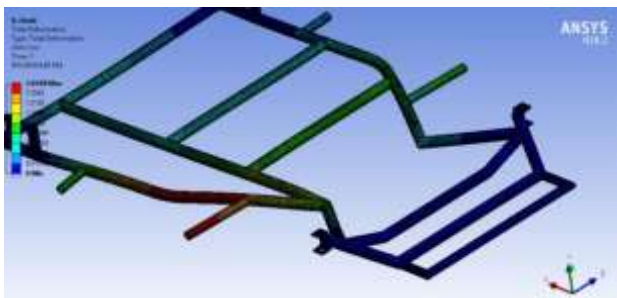

Fig- 19: SIDE IMPACT DEFORMATION, RIGHT SIDE

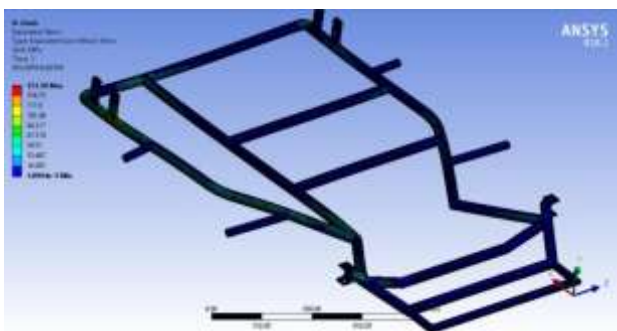

Fig- 20: SIDE IMPACT STRESS ANALYSIS, RIGHT SIDE

7.5 SIDE IMPACT (LEFT)

As shown in fig. 21 and 22, force of 3g ($2 \times 9.81 \times 120\text{kg}$) i.e. 3530 N was applied on the left side most member of the frame and deformation, stresses and FOS were calculated. The FOS was found to be 2.7 in fig. 212.

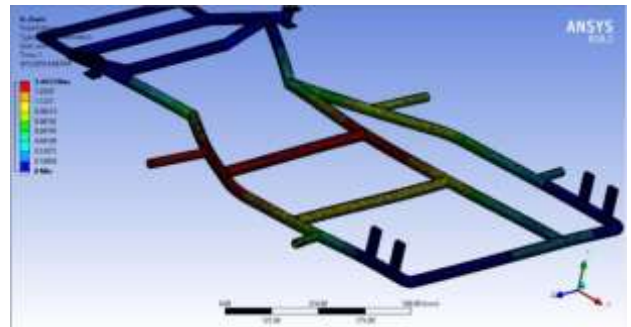

Fig - 21: SIDE IMPACT DEFORMATION, LEFT SIDE

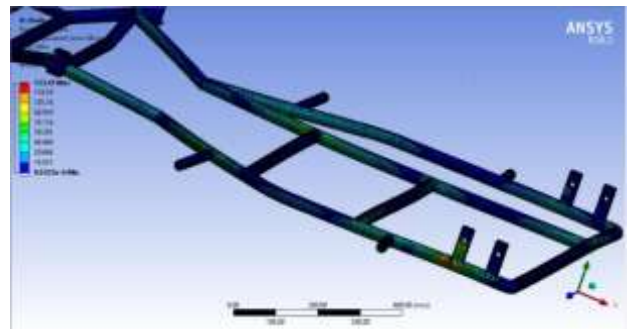

Fig- 22 : SIDE IMPACT STRESS ANALYSIS, LEFT SIDE

7.6 NODAL ANALYSIS

It is seen in modal analysis in fig. 23 that the maximum vibration (240 Hz) of the chassis and the minimum vibration (0 Hz) of the chassis don't match the natural frequency. As the matching causes resonance which might create a fracture on the chassis.

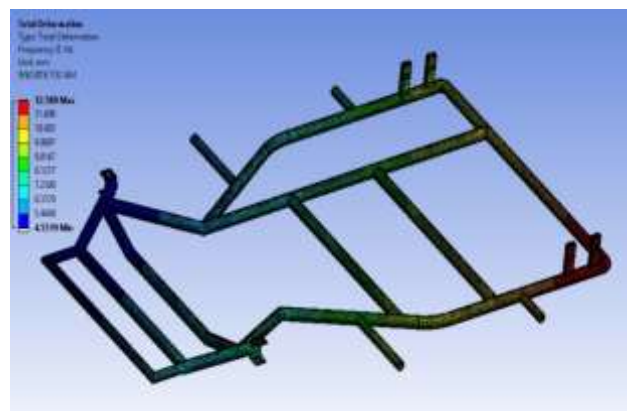

Fig- 23: NODAL ANALYSIS

8. SUBSYSTEMS OF GO KART

8.1 STEERING SYSTEM

The steering system for the vehicle has been designed to provide maximum control of the vehicle. Simplicity and safety were the main design specifications for the vehicle's steering system. The main goal for the steering system is to have steering radius 2.5m or less. Along with controlling the vehicle, steering system must provide good ergonomics and be easy to operate. After researching various steering systems, the Ackerman steering mechanism was selected which provides easy operation, less weight, less steering effort, requires low maintenance, provides excellent feedback and is cost effective. Fig. 24 shows the Ackerman angle by geometry method.

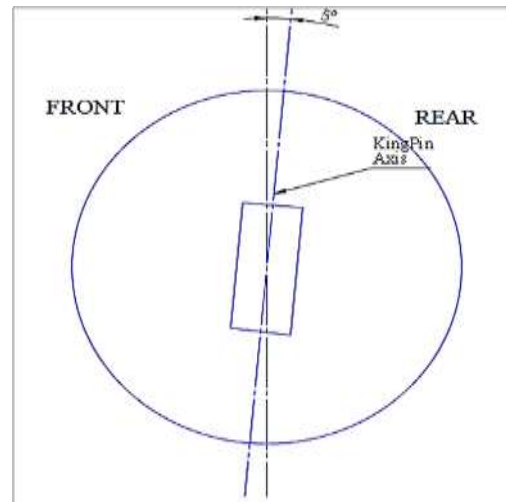

Fig- 25: CASTER ANGLE

8.1.2. KING PIN INCLINATION ANGLE AND CAMBER ANGLE

As shown in fig. 26, the king-pin inclination of 10 degree has been given making the knuckle retain its original position after performing a turn. As shown in fig. 27, the net camber angle was set to be zero, as the kart has tires having very less diameter which will not cause much effect but decreasing traction.

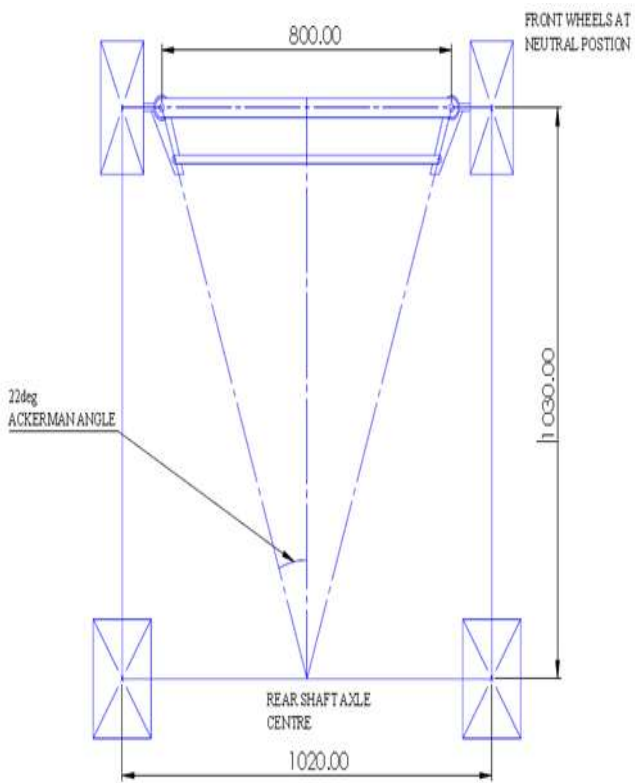

Fig- 24: ACKERMAN GEOMETRY

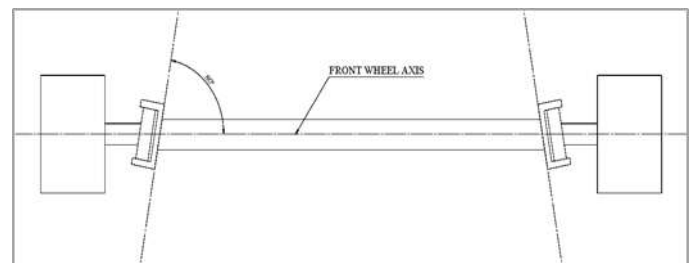

Fig- 26: KING PIN INCLINATION

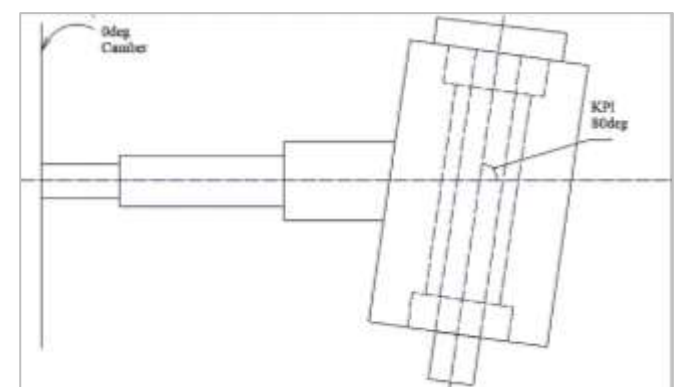

Fig- 27: CAMBER ANGLE

8.1.1 CASTER ANGLE

In fig. 25, caster angle of positive 5 degree has been given to the C bracket in the Knuckle assembly. Using of a positive castor angle in this case has given the kart a certain degree of self-centring. This increases the drive ability of the kart and helps the kart to not wander off the track.

Table - 4: STEERING PARAMETERS

Wheel base	1030 mm
Front track width	1020 mm
Ackerman angle	22°
Minimum turning radius	2000 mm
Max. inner angle	35°
Max. Outer angle	22°
King pin distance	800 mm
Scrub Radius	110 mm
Tie rod length	340 mm
Length of steering arm	80 mm
Caster angle	5°
Kingpin inclination	10°
Camber	0°
Steering Effort	156N

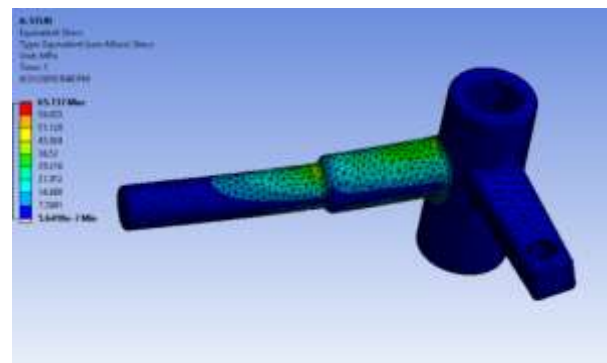

Fig- 29: STUB AXLE STRESS ANALYSIS

8.1.3. VARIOUS SUBSYSTEMS OF STEERING

8.1.3.1 Stub axle

High grade mild steel has been selected for the design of stub axle. Force equivalent to load of front tires, cornering force of 1.2g magnitude and kingpin movement were applied to respective points while constraining the stud in all the direction. For worst conditions, the deformation and the stresses are as follows as shown in fig. 28. And fig. 29. The FOS for the stub axle was 5.7

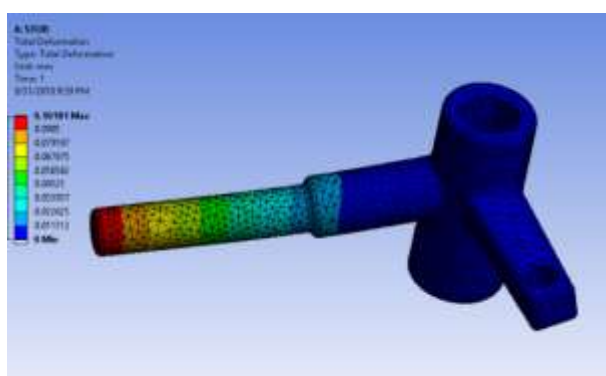

Fig-28: STUB AXLE DEFORMATION

8.1.3.2 Bracket

High grade mild steel has been used for the C bracket. For the worst case the deformation and equivalent stresses are analysed as follows as shown in fig. 30.

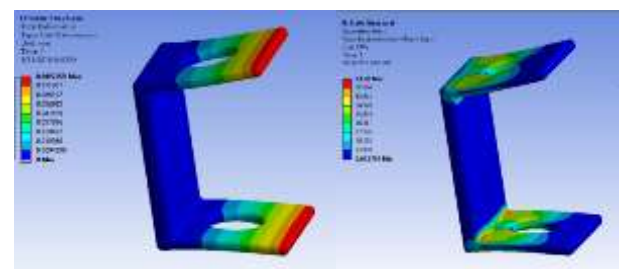

Fig- 30: C BRACKET ANALYSIS

8.2 TRANSMISSION

We have chosen a 4-stroke, 125cc single cylinder engine for the Go-Kart. After going through research papers and various surveys, Bajaj Discover 125cc DTSi (Digital twin spark ignition) engine was selected this can produce 11.5 PS of peak power and 10.8 Nm of peak torque. The maximum acceleration attained is 2.433 m/s² and can achieve a top speed of 110 km/hr, including the driver with an impressive fuel economy (50 kmpl) and overall performance blended with the go kart. The primary gear reduction ratio is 3.08 for the engine model and various gear reduction ratios are presented in table no. 5 and table no. 6.

Table -5: GEAR RATIOS

Primary Gear Reduction	3.08
1 st Gear Reduction	2.83
2 nd Gear Reduction	1.71
3 rd Gear Reduction	1.33
4 th Gear Reduction	1.08
5 th Gear Reduction	0.91
Maximum Engine RPM	8000 rpm

Table-6: GO-KART SPEED FROM ENGINE SPEED

Gear	Distance per Engine revolution.	Speed per 1000 rpm
1	310.15 mm	2.481
2	513.29 mm	4.106
3	659.5 mm	5.276
4	812.1623 mm	6.4973
5	963.885 mm	7.711

8.2.1. Shaft Design

The rear axle is used to transmit the power from engine to the rear tire through a chain drive. It is a solid shaft of diameter 30 mm and with a length of 1300 mm, according to design calculations. The material used is EN8 which is also known as AISI 1040 with the properties shown in table no. 7.

Table -7: EN8 PROPERTIES

Mechanical Properties	
Ultimate Tensile Strength	620 MPa
Yield Strength	415 MPa
Hardness	58 Rockwell
Density	7.845 g/cc
Youngs Modulus	210 GPa
Chemical Properties	
Iron (Fe)	98.60%
Manganese (Mn)	0.60%
Carbon (C)	0.40%
Sulphur (S)	0.05%
Phosphorous (P)	0.04%

As shown in fig. 31, the shaft analysis was done by constraining the end points and torque is applied in the centre.

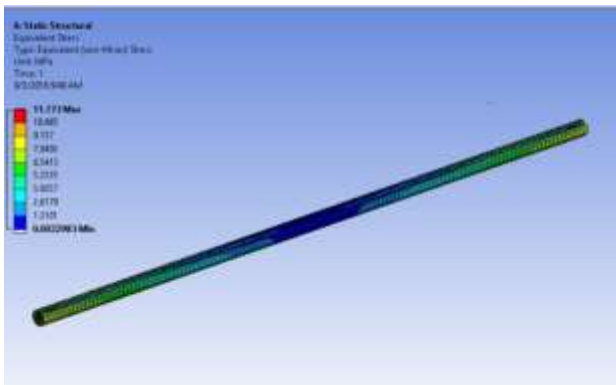

Fig- 31: SHAFT STRESS ANALYSIS

8.2.2. Chain Drive

Chain Drive is the way of transmitting power from one component to another. For the go kart, roller chain type of transmission was used reason being It is simple to design, easy to install and It is cost efficient. The chain type used is Roller chain, the pitch of the train is determined by the power rating table as shown in table no. 8.

Table -8: CHAIN SPECIFICATIONS

Maximum torque at rear axle	50 Nm
Chain Type	Roller Chain
Chain number	40
Chain Pitch	1/2 inch
Length of Chain	50 pitches
Ideal Centre Distance	127.1 mm
Diameter of Shaft	30mm
Driving Sprocket	
Number of Teeth	14 Teeth
Pitch circle diameter	57.07 mm
Driven Sprocket	
Number of Teeth	42 Teeth
Pitch circle diameter	85

8.3 BRAKING SYSTEM

A brake is a device by means of which frictional resistance is applied to a moving machine member, in order to stop the motion of machine. Most brakes commonly use friction between two surfaces pressed together to convert the kinetic energy of moving object into heat energy. A quality braking system enables the driver to navigate through the turns and corners with desired motion. A good braking system ensures smooth riding and excellent manoeuvrability.

TABLE - 9: BRAKE PARAMETERS

Brake Type	Hydraulic Disc Brake
Brake Material	SS 304
Disc Diameter	170 mm
Master Cylinder Diameter	10 mm
Caliper Piston Diameter	25.4 mm
Disc Thickness	4 mm
Pedal Force Applied	189.39 N
Pedal Ratio	03:01

As shown in table no. 9, brake design parameters include choosing of material for the disc, determining the thickness, determining the brake fluid to be used. Brake fluid plays an important role in the braking system as it transfers the pressure energy without getting compressed. According to fig. 32 graph, Knee Angle (β)= 150° , Driver can exert weight from 19kg to 240kg (Depends upon weight of driver; Pedal force can be taken as half the weight of driver) But considering safety reasons, we are taking it minimum.

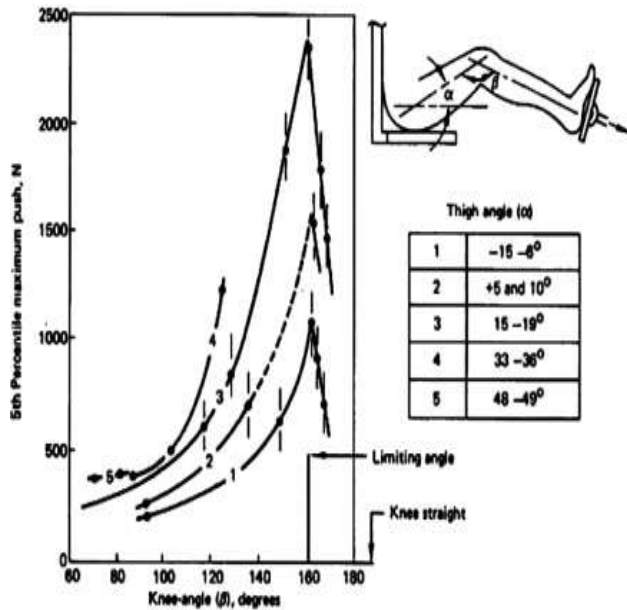

Fig- 32: FORCE AT DIFFERENT LEG ANGLES

TABLE - 10: CALCULATED RESULTS OF BRAKE SYSTEM

Pedal Force	186.39 N
Brake Line Pressure	9.065 MPa
Clamping Force	9186.6 N
Rotating Force	5511.96 N
Braking Torque	468.51 Nm
Braking Force	2682.94 N
Deceleration	16.76 m/s^2
Stopping Distance	4.66 m
Stopping Time	0.75 sec

As shown in fig. 33 and fig. 34, the analysis was done for deformation, stress and thermal module on the disc. Boundary conditions for the analysis were constraining the hub holes and applying the torque on the hub. The FOS were 1.3.

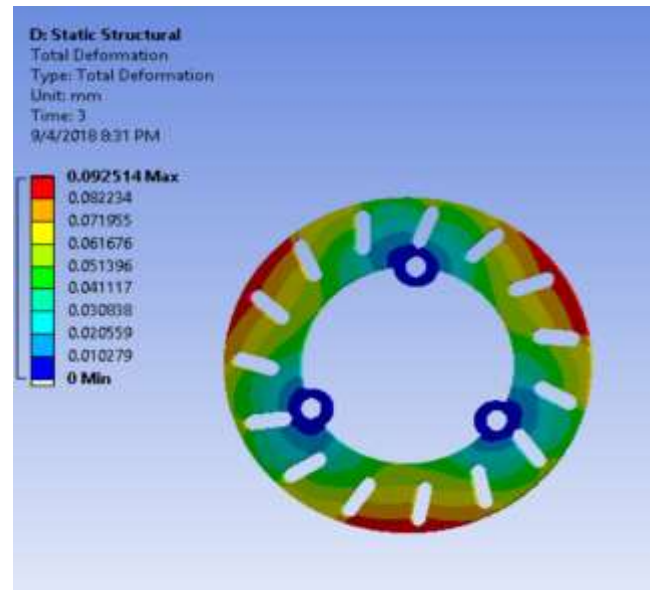

Fig-33: BRAKE DISC DEFORMATION

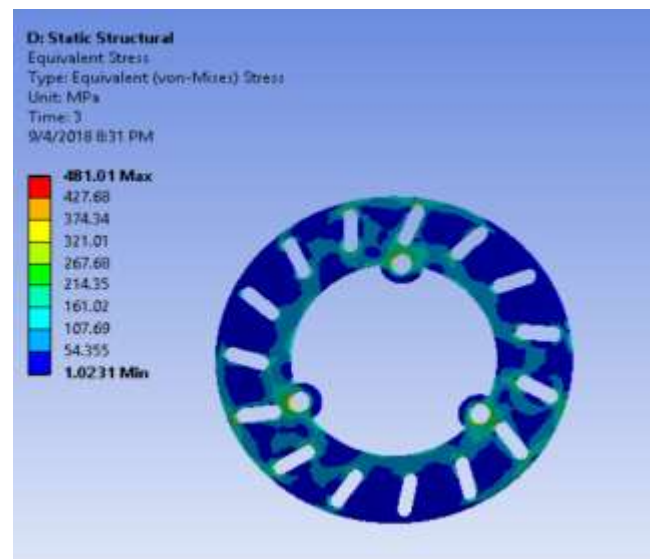

Fig- 34: BRAKE DISC STRESS ANALYSIS

9. CONCLUSION

A go-kart is a racing vehicle with various sub systems like a domestic car except that it doesn't have a suspension system. The main stages include the designing, stress analysis, fabrication of the kart for completion of a perfect go-kart. This paper has stressed on the ergonomics, comfort, aesthetics along with outlining the main sub systems of the kart. An overview of choosing the most optimum material in terms of strength, cost is given in this paper. As much as internal features of a vehicle are important so are the external features. Aesthetically, rounded corners are used instead of straight as to allow for more pleasing look as well as vehicle's body, reducing number of welded joints. All of these factors and analysis has led to fabrication of a ideal kart that can participate in national level racing championships.

10. REFERENCES

1. Indian Karting Championship Rule Book.2018.
2. Harshal D.Patil, Saurabh S. Bhange, Ashish S. Deshmukh, "Design And Analysis Of Go-Kart Using FEA Method" International Journal of Innovative and Emerging Research in Engineering Volume 3, Special Issue 1, ICSTSD 2016
3. Koustubh Hajare, Yuvraj Shet, Ankush Khot."A Review Paper On Design And Analysis Of A Go Kart Chassis" International Journal of Engineering Technology, Management and Applied Sciences, www.ijetmas.com, February 2016, Volume 4, Issue 2, ISSN 2349-4476
4. National Aeronautics and Space Administration Space Station Program Office Johnson Space Center Houston, Texas, pg 4-5, "International Space Station Flight Crew Integration Standard (NASA-STD-3000/T)", 9 International Space Station, Revision C 15 December 1999.
5. V.B.Bhandari, "Design Of Machine Elements"
6. R.K.Bansal, "Strength Of Material"