

# Design and Development of Conveyor System for Scrap Collection of Tab Blanker Machine in Battery Manufacturing Company

Adsul Sujit<sup>1</sup>, Amte Suhas<sup>2</sup>, Bhure Machchhindra<sup>3</sup>, Deshmukh Avinash<sup>4</sup>, Dr. Anil Sahu

Department of Mechanical Engineering, GHRCEM, Pune, Maharashtra Internal Guide, Department of Mechanical Engineering, GHRCEM, Pune, Maharashtra, India

\*\*\*

**Abstract** - In general conveyor system is a common piece of mechanical handling equipment that moves materials from one location to another. Conveyors are especially useful in applications involving the transportation of heavy or bulky materials. Conveyor systems allow quick and efficient transportation for a wide variety of materials, which make them very popular in them material handling industries. In Exide Industries Ltd. Expander machine and Tab Blanker machine in which the processing of negative grid is carried out. During the process from these machines scrap material is removed and conveyed by the two separate conveyor which is electrically driven. If we combine the flow of scrap from both expander machine and tab blanker machine in a conveyor which is already arranged for the expander machine So we will eliminate the conveyor of the tab blanker machine and also electrical power required, maintenance, time, material handling and saving of cost.

**Key Words:** Material Handling System (MHS), Tab Blanker Machine, Gravity Conveyor.

## 1. INTRODUCTION

Material handling involves short-distance movement within the confines of a building or between a building and a transportation vehicle. It uses a wide range of manual, semi-automated, and automated equipment and includes consideration of the protection, storage, and control of materials throughout their manufacturing, warehousing, distribution, consumption, and disposal. Material handling can be used to create time and place utility through the handling, storage, and control of material, as distinct from manufacturing, which creates form utility by changing the shape, form, and makeup of material.

Material handling is integral to the design of most production systems since the efficient flow of material between the activities of a production system is heavily dependent on the arrangement of the activities. If two activities are adjacent to each other, then material might easily be handed from one activity to another. If activities are in sequence, a conveyor can move the material at low cost. If activities are separated, more expensive industrial trucks or overhead conveyors are required for transport. The high cost of using an industrial truck for material transport is due to both the labor costs of the operator and the negative impact on the performance of a production system when multiple units of material are combined into a single transfer batch in order to reduce the number of trips required for transport. Manual material handling ranges from movement of raw material, work in progress, finished goods, rejected,

scraps, packing material, etc. These materials are of different shape and sizes as well as weight. Material handling is a systematic and scientific method of moving, packing and storing of material in appropriate and suitable location. Automated materials handling (AMH) refers to any automation that reduces or eliminates the need for humans to check-in, check-out, sort material, or to move totes and bins containing library material.

The mechanical equipment used in AMH systems includes check-in machines, sorters, conveyors, simulators, stackers and unstackers, totes, bins, trolleys, and tote carriers. Somewhere in the process there must be a scanner to read the bar code or a reader to read the RFID tag (or both.) Various belts, pulleys, chutes, slides, and laser beams are used to ensure bins don't overflow and to get each item oriented correctly and pushed or carried into the right tote or bin. Self-check-out machines are sometimes lumped into the AMH category because they take the check-out step out of the hands of staff. However, they do so by having the patron do it themselves so it is more of a self-service feature than automation.

## 2. LITERATURE REVIEW

Alsbaugh M. A. presented latest development in belt conveyor technology & the application of traditional components in non-traditional applications requiring horizontal curves and intermediate drives have changed and expanded belt conveyor possibility. For Examples of complex conveying applications along with the numerical tools required to insure reliability and availability will be reviewed. This paper referenced Henderson PC2 which is one of the longest single flight conventional conveyors in the world at 16.2611 km. But a 19.123 km conveyor is under construction in the USA now, and a 23.52 km flight is being designed in Australia. Other conveyors 30-50 km are being discussed in other parts of the world.

I.A. Daniyan discussed the design calculations and considerations of belt conveyor system for limestone using 3 rolls idlers, in terms of size, length, capacity and speed, roller diameter, power and tension, idler spacing, type of drive unit, diameter, location and arrangement of pulley, angle and axis of rotation, control mode, intended application, product to be handled as well as its maximum loading capacity in order ensure fast, continuous and efficient movement of crushed

limestone while avoiding halt or fatalities during loading and unloading.

**Following are the factors which consider to reduce the Material Handling-**

- **Right Amount:** The concept of just-in-time inventory management emphasizes the importance of holding the right amount of material both in manufacturing and distribution.
- **Right Material:** An accurate identification system is necessary in order to pick and deliver the right material to the lines.
- **Right Condition:** The quality of the delivered material should fulfil the desired expectations without damages/defects.
- **Right Sequence:** The impact of the sequence of activities performed in a material handling operation is very evident. Therefore, it is important to move, store, protect, and control materials in the right sequence.
- **Right Orientation:** Physical orientation of materials represents a significant portion of people’s activities both in manufacturing and distribution. Therefore, regaining the orientation of material will save valuable time.
- **Right Place:** The necessary material should be delivered at the point of use which can save undesired movements.
- **Right Time:** The need for the material handling system to move, store, protect, and control materials at the right time is increasingly important due to time-based competition.
- **Right Cost:** Right cost does not necessarily mean that a firm should decrease the cost of MHS. On the contrary, the system should be designed with competitive advantages, so it can be a revenue enhancer rather than a cost contributor.
- **Right Methods:** To perform all the mentioned points above in a right way, it is necessary to use the right methods.

**WORKING OF MACHINES ON SITE-**

**Grid Casting machine:-** In this section of negative grid casting machine the raw material is lead ingot is feed to the furnace in which melt and pass to the continuous casting machine in which the grid sheet is formed having thickness of 12 mm. This continues formed grid sheet is passed through the simple two rollers have no of stages of two rollers which reduces the thickness of the grid sheet up to 0.7 mm. this sheet is then wound around the roller of equal interval of 800 m.

**Expander unit:-** This sheet is unwound by the decoiler to the expander machine through various idle/guide rollers. In this expander machine the sheet is deformed into thin sheet by press roller of thickness 0.4 mm and width 170mm. Then

it is feed to the punching through the guide rollers and then punched by bunch of punches and form a grid sheet and the blanks are as a raw material is collected in the container through the in continuous manner by using conveyer.

**Tab blanker Machine:-** The finally formed grids by expander units is goes to the tab blanker machine. On this machine we are putting the knuckle end to the grid plate and remaining scrap is removed with the help of blanker, again this removed scrap is carried away with the help of hopper and conveyer arrangement. The scrap removed from the Expander unit and tab blanker machine is collected in the container through the conveyer and then it id recycle in the furnace.



**Fig.1** Expander unit and Tab blanker machine.

**4.1 SUGGESTED MATERIAL HANDLING SYSTEM-**

The problem in the previous arrangement of raw material handling system is as follows-

- Two conveyer is required for higher altitude.
- Two separate electric motors are required to drive the conveyer.

Considering above problem we are suggesting following arrangement of the raw material handling system as a solution. In this new arrangement the raw material from both the machines is collected and conveyed by single conveyer in one container instead of using two. So there is electric power required is less than the previous arrangement and also this is simple arrangement, Installation cost of conveyer is reduced and also maintenance of conveyer.

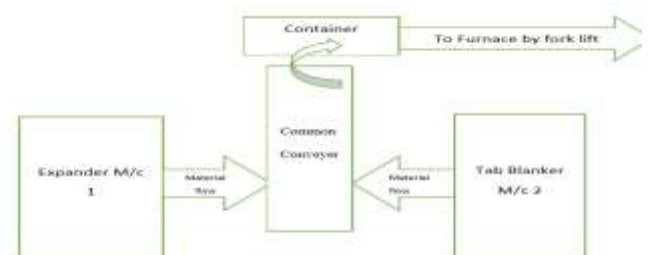

**Fig.2** Suggested MHS

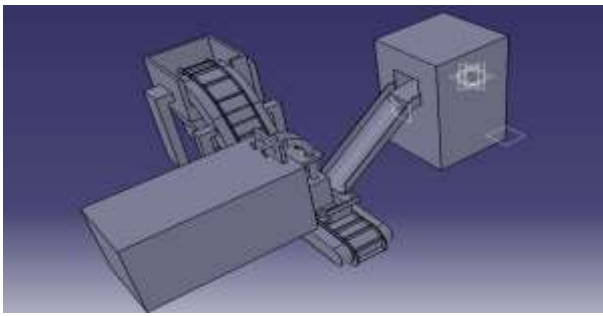

Fig 3. CATIA model

### 3. CALCULATIONS

Required Dimensions of Raw material conveyer :-

Length=87"

Height=38"

According to Pythagoras theorem,

$$(38)^2 + (87)^2 = (x)^2$$

$$x = 94.93"$$

#### 3.1 ELECTRICAL POWER CONSUMPTION AND COST SAVED

1HP=746 watt

1unit=(Watt\*hours)/1000

$$= (746*18)/1000$$

$$= 13.428 \text{ unit/day}$$

Assume, working hours is 24 for day and weekend holiday is 12 hours therefore

working day per year =  $365 - 0.5*52 = 339$  day/year

number of units per year =  $13.428*339 = 4552$  units/year

Assume industrial electrical units cost is 10 Rs uniformly throughout the year

Cost of unit per year =  $4552*10 = 45,520$  Rs/motor/year

As there are 2 motors are running for two machines to convey the raw material

Cost of two motors per year =  $2*45520 = 91,040$  Rs.

In our suggested material handling system we are reducing two motors as suggested MHS so cost save by one motor is 45,520 Rs.

### 4. CONCLUSION

In this project as our objective is to identify the scope of automation in production line. We had observed that the company has two tab blanker machine in the production line and it has been also observed that to collect the scrap there are two conveyor system which individually run by separate motor of 1 HP. While critically observing we had find out that, it is possible to remove the one conveyor and one motor which is running that conveyor and directly scrap can be possible to collect by using the gravity conveyor. Total cost will reduce if they implement our suggestion for two machine RS. 1,80,040 per year. While reducing the conveyor system more space will created and it will helpful for the movement of the fork lift.

### ACKNOWLEDGEMENT

The authors would like to thanks Dr. Anil Sahu for whom we have greatest amount of respect admiration. He has not only afforded us the opportunity to work on this topic but also provided valuable guidance and support throughout our time as student in G.H.Raisoni College Of Engineering And Management, Pune department of mechanical engineering.

We are sincerely thankful to Dr. R.R. Arakerimath (HOD) of mechanical department, for there kind guidance and support throughout this work.

We also like to thanks Mis. Nehma Gidh (HR) Mr. O.P.Modi & Mr. B.C Patil (Production Head) for allow us in Exide Industries LTD. Chinchwad for sponsor Project.

### REFERENCES

- 1). P. Sunderam, E. Viswanathan, (2014), "Development of Material Handling System in a Manufacturing Company", International Journal of Innovative Research in Science, Engineering and Technology, Vol. 3, PP:8909-8913, ISSN: 2319-8753
- 2). Kulkarni Prabhanjan, P. Gudhate, Saurabh S, (2016), "Design and Analysis of Material Handling system", International Journal for the Innovative Research in Science and Technology (IJIRST), Vol. 2, PP: 43-52, ISSN: 2349-6010
- 3). Waghmare santosh R. Tolmare Ashish M. Praveen K. Mali, (2016), "Design and analysis of material handling system", International Research Journal of Engineering and Technology (IRJET), Vol:3, PP: 2516-2533, ISSN: 2395-0056
- 4). Alspaugh M. A, (2013), "Design and Development of Automated Conveyor System for Material Handling", ISOR journal of Mechanical Engineering, PP 31-34, ISSN: 2278-1684
- 5). Sera Akincilar, Cameron Rad, (2013), "Material Handling System Design: A Case-Study in Bosch Rexroth Japan", International Research journal of Engineering and Technology.