

# DESIGN AND FABRICATION OF MANUALLY OPERATED SEED SOWING MACHINE

R. Kathiravan<sup>1</sup>, P. Balashanmugam<sup>2</sup>

<sup>2</sup>Assistant professor, Department of Mechanical Engineering, Annamalai University, Tamilnadu, India (On Deputation)

<sup>1</sup>Lecturer (Part-time/Guest Lecturer) Department of Mechanical Engineering, Central Polytechnic College, Tharamani, Chennai-113, Tamilnadu, India

**Abstract** This article addresses betterment in agricultural processes. Manually operated seed sowing machine consist of mechanisms for sowing of the seed. This mechanism runs simultaneously. The essential objective of sowing operation is to put the seed in desired depth and provide required spacing between the seeds and cover the seeds with soil. We can achieve optimum yield by proper compaction over the seed and recommended row spacing. To meet the demands farmer have to use new techniques in cropping to increase the yield. The requirements of small scale sowing machines are, they should be simple in design, affordable for small scale peasant farmers, easy maintenance for effective handling by unskilled farmers. In this project the attempt has been made for reduction in cost of machine and developing the multifunctional sowing machine which can perform simultaneous operations.

**Key Words:** Multiple cropping, broadcasting, seed planter machine, Dibbling, Seed meter mechanism

## 1. INTRODUCTION

Indian economy is based on agriculture. Development in agriculture leads to raise economic status of country. In India farmers are facing problems due to unavailability of labours, traditional way of farming using non efficient farming equipments which takes lot of time and also increases labour cost. This project is all about enhancement in seed sowing and pesticide spraying like farming operations by using multifunctional seed sowing machine. The main objective of sowing operation is to place seed at proper position respective of other placed seeds in every row at particular depth and provide a cover of soil on it. As per change in shape and size of different seeds the parameters like distance between two seed, depth of seed, planting rate chances.

This research is attempt to produce multifunctional and highly efficient seed sowing machine which will reduce time of plantation, cost of labour, and enhances production. Traditional method of seed sowing based on assumptions of seed to seed spacing and depth of placement which is not at all efficient and beside this it requires lot of time and efforts too. Sometime it results in back ache of farmers. As per change in climate farmers are facing one more problem which occurs due to harmful insects and pest. Farmers have

to stay alert for fighting to this problem by using different pesticides .pesticide spraying is one of the common operations in agriculture field which requires lots of efforts to carry the pump in farm. It results in shoulder pain so badly. This machine contains pesticide spraying too which make it multifunctional. This project addresses improvement in agriculture processes like sowing of seeds on ploughed land and distribution of fertilizer combinable by using mechanisms. Primarily this system works manually, but with lesser input energy requirement.

Seed sowing machine is a device which helps in the sowing of seeds in the desired position hence assisting the farmers in saving time and money. The basic objective of sowing operation is to put the seed and seed in rows at desired depth and seed to seed spacing, cover the seeds with soil and provide proper compaction over the seed. The paper discusses different aspects of seed sowing machine which will be helpful for the agriculture industry to move towards mechanization. The agricultural industry has always been the backbone of India's sustained growth. As the population of India continues to grow, the demand for produce grows as well. Hence, there is a greater need for Multiple cropping on the farms and this, in turn, requires efficient and high-capacity machines. Mechanization of the Agricultural industry in India is still in a stage of infancy due to the lack of knowledge and the unavailability of advanced tools and machinery. In traditional methods seed sowing is done by broadcasting manually, opening furrows by a plough and dropping seeds by hand. The agricultural has always been the backbone of India's sustained growth. As the population of India continues to grow, the demand for produce grows as well. Hence, there is a greater need for multiple cropping in the farms and this, in turn, requires efficient and time-saving machines. The paper discusses different types of seed sowing machine which will be helpful for the agriculture industry to move towards mechanization.

**Traditional Sowing Methods:** Traditional methods include broadcasting manually, opening furrows by a country plough and dropping seeds by hand and dropping seeds in the furrow through a bamboo/metal funnel attached to a country plough. For sowing in small areas dibbling i.e., making holes or slits by a stick or tool and dropping seeds by hand, is practiced. Multi row traditional seeding devices with manual metering of seeds are quite popular with

experienced farmers. In manual seeding, it is not possible to achieve uniformity in distribution of seeds. A farmer may sow at desired seed rate but inter-row and intra-row distribution of seeds are likely to be uneven resulting in bunching and gaps in the field.

Traditional sowing methods have following limitations:

- In manual seeding, it is not possible to achieve uniformity in distribution of seeds.
- A farmer may sow at desired seed rate but inter-row and intra-row distribution of seeds are likely to be uneven resulting in bunching and gaps in field. Poor control over depth of seed placement. Labour requirement is high because two persons are required for dropping seed and seed.

The effect of inaccuracies in seed placement on plant stand is greater in the case of crops India is set to be an agricultural based country approximately 75% of the population of India is dependent on farming directly or indirectly. Our farmers are using the same methods and equipment for the ages. E.g. seed sowing, spraying, weeding etc. There is a need for the development of effective spraying and weeding machine for increasing the productivity. Most of the developing countries of Asia have the problem of high population and low level of land productivity as compared to the developed nations. One of the main reasons for low productivity is insufficient power availability on the farms and low level of farm mechanization. This is especially true for India. It is now realized the world over that in order to meet the food requirements of the growing population and rapid industrialization, modernization of agriculture is inescapable. It is said that on many farms, production suffers because of improper seedbed preparation and delayed sowing, harvesting, and threshing. Mechanization enables the conservation of inputs through precision in metering ensuring better distribution, reducing quantity needed for better response and prevention of losses or wastage of inputs applied. Mechanization reduces the unit cost of production through higher productivity and input conservation.

Agricultural implement and machinery program of the government has been one of selective mechanization with a view to optimize the use of human, animal and other sources of power. In order to meet the requirements, steps were taken to increase the availability of implements, irrigation pumps, tractors, power tillers, combine harvesters and other power operated machines and also to increase the production and availability of improved animal-drawn implements. Special emphasis was laid on the later as more than 70% of the farmers fall in small and, marginal category. It is generally said that mechanization of small farms is difficult. But Japan having average land holding even smaller than ours, with proper mechanization has led agriculture to great heights. In order to minimize the drudgery of small farmers, to increase efficiency and save farmer's time for

taking up additional /supplementary generating activities, the use of modern time-saving machines/implements of appropriate size needed to be suitably promoted.

The Automatic seed sowing machine are developed. In this proposed work they have focused on seed sowing process. In this seed sowing process to avoid the drawbacks. The seed sowing machine is developed which has very less cost. Also the unskilled farmer can be easily operated automatic seed sowing system.

Researchers have presented a better speed of operation and good Seed Sowing capacity for new advanced agriculture process which includes robotic based cultivation. An agriculture robotic system is used. They has used DC motor which has four wheels. An agricultural farm is cultivated by the Plow machine, depending on the crop considering particular rows specific columns. Ultrasonic sensor detects the blocks in the path with measure the distance between both robot and block. Also senses turning position of our vehicle at end of the each column. The seed block can be detected and solved using water pressure. This machine can be controlled on remotely. A sensor guided robot rover for digging, precise seed positioning and sowing has been proposed to reduce the human effort.

Researchers have presented a multi-class image segmentation to automate fruit segmentation. The proposed algorithm is applied to fruit segmentation. This problem for a robotic agriculture observation mission. The aim to provide yield estimation with high correctness as well as robustness against fruit variance.

Researchers have presented a system in which a robot machine. The different sensors are used to control different parameters of robot for sowing the seeds by using microcontroller. At the end of field using remote switch and the position of wheels changed. Seeds are empty alarm is detected.

Researchers have presented a system which is solar based automatic seed sowing. In village the farmers mainly income depends on the agricultural source. Automatic seed sowing machine is fulfil the digging, seed sowing, water pouring and fertilizing by using solar energy. This automatic seed sowing machine is help to the farmer. And also they can perform their regular cultivation activity as well as saves fuel up to larger extent. At the same time by using solar energy environment pollution can be reduced.

Researchers have developed seed planter machine. It should be easily for simple farm, design and technology. The manually operated template row planter is designed and developed to improve planting efficiency and reduce drudgery involved in manual planting method. Seed planting is also possible for different size of seed at variable depth and space between two seed. Also it increased seed planting, seed fertilizer placement accuracies. The system can very simple for unskilled farmers and easily handled. By using of

this machine, achievement of flexibility distance and depth variation for different seed plantation is possible.

Agriculture is main occupation in India. 70% population to live in village. There are different type of traditional method are used. In Traditional method of sowing seeds is very bulky. The farmer has to sow the seeds are manually. This is very time to spend this process and also the wastage of seeds.

In this design, the drive shaft directly controls the seed metering mechanism which eliminates completely attachments such as pulleys, belts system, thereby eliminating complexities which increase the cost, and increasing efficiency at a highly reduced cost which is the focus of this project work. This system is very much beneficial to all farmers because the wastage of seeds and more man power are avoided for that system. Also the time to be saves. All facilities to be provided in automatic seed sowing machine. In seed sowing machine system they are used battery powered wheels and dc motor inbuilt in these wheels. In this system seed storage tank are used .when the seeds are empty it detect the level of storage seed and indicate the alarm. When any obstacle comes in the in-front of machine or divert path the seed sowing machine can detect this obstacle very easily. The end of system machine reached and it create alarm. This system provides to all the facility which can work efficiently. Also the farmer can sow the seed very much easily. As well as time will be save. This system is very useable to farmer .seed can be sow automatically.

### 1.1. Traditional seed sowing techniques

- Line sowing

It is the dropping of seeds into the soil with the help of implement such as mogha, seed drill, seed-cum-ferti driller or mechanical seed drill as shown in figure 1. Crops like Jowar, wheat Bajara, etc. are sown by this method.



Fig.1 Line sowing

- Dibbling

It is the placing seeds at cross marks made in the field. It is done manually by dibbler. This method is followed in crops like Groundnut, Castor, etc.

- Broad Casting

It is the scattering of seeds by hand all over the prepared field as shown in figure 2. Crops like wheat, methi, etc. are sown by this method.



Fig.2 Broadcasting

- Putting Seeds behind the Plough

It is dropping of seeds behind the plough in the furrow with the help of manual labour by hand. This method is followed for crops like wal or gram.

### 1.2. Factors Affecting Seed Emergence

Mechanical factors, which affect seed germination and emergence, are:

- Its depth should be uniform with regard to placement of seed
- It should be distributed uniformly along the rows.
- Its transverse displacement with regard to row also considered.
- Loose soil getting is also prevented.
- Soil is covered uniformly over the seed.
- Fertilizer is mixed with seed during placement in the furrow.

By fulfilling above factors we get best performance of the seed drill or planter. To improve the performance we need to optimize the above factors also so that we get desired efficacy from the system in economical way. Its design is simplified and components are selected to suit the need of the corps. In the working of the robot seed drill or planter also plays vital role in manipulating the physical environment. The metering system allows the metered or required quantity of the seed in the farm. This system also serves the seed so that seed should not be damaged while working.

## 2. LITERATURE REVIEW

Klocke (1979) described the building of two experimental planters, one using a smooth coulter and the other a ripple edged coulter. Both types of coulters were followed by hoe openers. The performance of the drills was satisfactory as long as the seed was placed into adequate soil moisture. Kumar et, at. (1986) developed a manually operated seeding attachment for an animal drawn cultivator. The seed rate was 43.2 kg/hr while the field capacity was 0.282 ha/hr.

Tests showed minimal seed damage with good performance for wheat and barley. Adisa and Braide (2012) developed template row crop planter.

Bamgboye and Mofolasayo (2006) developed a manually operated two-row Okra planter. The field efficiency and field capacity were 71.75% and 0.36 ha/hr while seed rate was 0.36kg/hr with low average seed damage of 3.51%. Gupta and Herwanto (1992) designed and fabricate a direct paddy seeder to match a two-wheel tractor. The machine had a field capacity of about 0.5 ha/hr at a forward speed of 0.81mls, and there was no damage caused by the metering mechanism for soaked seeds; though 3% damage was recorded for pre-germinated seeds.

Molin and D' Agostin (1996) developed a rolling planter for stony conditions, using 12 spades radially arranged with cam activated doors and a plate seed meter. Performance evaluation showed important improvement in the planting operation with reduction in human effort, more accurate stands and high field capacity.

Ladeinde and Verma (1994) compared the performance of three different models of Jab planters with the traditional method of planting. In terms of field capacity and labour requirement, there was not much difference between the traditional planting method and the Jab planters. However, backache and fatigue were substantially reduced while using the planters. Hand-pushed and Transnational Journal of Science and Technology August 2012 edition volume2, No.728 tractor mounted row seeders (usually single and multiple row). Normally requires a well prepared seed-bed which may be ridged or flat bed. The single and double row planters developed at the University of Southern Mindanao Agricultural Research Center (USMARC) can plant a hectare within 6-8 hours for single-row and half so much time for double-row. A disc type maize seeder developed which is simple in design and can be handily operated with ease and comfort. This is a labour intensive and time consuming process. Lara-Lopez developed a single-row direct planter for maize. The planter may be attached to a walking or riding type two-wheel tractor.

Singh designed and developed a two-row tractor drawn ridge planter for winter maize. Bamgboye and Mofolasayo tested a manually operated two row okra planter developed from locally available materials. The planter had a field capacity of 0.36 ha/h with a field efficiency close to 72%. In this paper we are designing of an advanced manual operated multi-crop seed planters, their utilization methods advantages, disadvantages and the process involving to design and fabrication of these planters for the purpose of utilization of poor farmers.

Mahesh R. Pundkar and A. K. Mahalle is presented review provides brief information about the various types of innovations done in seed sowing machine available for plantation. The seed sowing machine is a key component of agriculture field. The performance of seed sowing device has

a remarkable influence on the cost and yield of agriculture products. Presently there are many approaches to detect the performance of seed-sowing device

Laukik P. Raut and et. al., studied to meet the food requirements of the growing population and rapid industrialization, modernization of agriculture is inescapable. Mechanization enables the conservation of inputs through precision in metering ensuring better distribution, reducing quantity needed for better response and prevention of losses or wastage of inputs applied. Mechanization reduces the unit cost of production through higher productivity and input conservation.

D. Ramesh and H. P. Girish Kumar presented review provide brief information about the various types of innovations done in seed sowing equipment. The basic objective of sowing operation is to put the seed and seed in rows at desired depth and seed to seed spacing, cover the seeds with soil and provide proper compaction over the seed. The recommended row to row spacing, seed rate, seed to seed spacing and depth of seed placement vary from crop to crop and for different agro-climatic conditions to achieve optimum yields. Seed sowing devices play a wide role in the agriculture field.

Pranil V. Sawalakhe and et. al., are investigated the today's era is marching towards the rapid growth of all sectors including the agricultural sector. To meet the future food demands, the farmers have to implement the new techniques which will not affect the soil texture but will increase the overall crop production. This Paper deals with the various sowing methods used in India for seed sowing and seed placement.

Mahesh R. Pundkar stated that the seed sowing machine is a key component of agriculture field. high precision pneumatic planters have been developed for many varieties of crops, for a wide range of seed sizes, resulting to uniform seeds distribution along the travel path, in seed spacing. P.P. Shelke concludes that bullock drawn planters are becoming necessity for sowing as the skilled workers for sowing are almost diminishing. Planting distance and plant population are crucial factors in maximizing the yields of crops. Singh revealed that by using a seed drill for wheat crop there was an increase in yield by 13.025 percent when compared with the conventional method, it also revealed that by using a seed drill for wheat crop, a saving of 69.96 per cent in man-hours and 55.17 percent in huloock hours was achieved when compared, with the conventional method. Umed Ali Soomro et al. in Pakistan has evaluated three sowing methods and seed rate in a four replicated RCBD method and concluded that drilling method of sowing at seed rate 125 kg/ha is optimal for yield and quality of wheat grains, because the said sowing method and seed rate distribute seed uniformly and desired depth which provide appropriate depth for seed germination and crop establishment.

### 3. DESIGN OF SEED SOWING MACHINE

The figure 3 shows the detailed drawing of seed sowing machine design mechanism. It is designed as per farm condition also it is as per the requirement so that it can dig the required size of rows for seed sowing. First we fill the hopper with seeds manually. System that will be made, uses the manual push force to run mechanism. Rotary motion of wheels provided to the sowing shaft (which will be placed in seed storage tank) by sprocket or belt drive. With controlled distance interval, seed gets sowed in land via pipe and digging arrangement and seed is covered with soil.

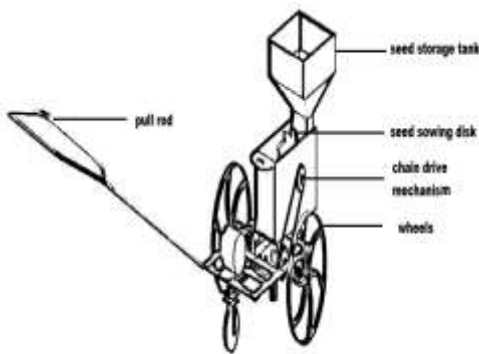

Fig.3 Design of seed sowing machine

#### 3.1. Seed meter mechanism

Rotary motion of wheels provided to the sowing shaft (which will be placed in seed storage tank) by sprocket or belt drive. Due to this shaft will rotate and it drops the seed from the hopper or seed meter box to the digger through the hose for digging purpose. For one revolution of shaft, only one seed is required to deposit; this function can be fulfilled by using a bush.

#### 3.2. Digger mechanism

Digger mechanism is used for digging and seeding. The digger itself is used as a digging tool. The digger is connected to the frame by a nut and bolt. There are three adjustable diggers as shown in figure 4. A digger has a flapper for opening into the cavity for seeding. The flapper is connected to the hopper with the help of a hose.



Fig.4 Digger mechanism:

#### 3.3. Seed storage tank

The storage device is one of the important devices of the system. It is designed according to the weight sustained by the robot as well as the required capacity for planting. This component is stationary. At the bottom of this tank, a seed sowing disc is arranged as shown in figure 5. This disc serves the function of distribution of the seeds, as for each complete rotation of the rotating wheel, only one seed falls from the tank. Also, the number of seeds falling from the tank is varied according to requirements. This disc evenly opens the way to seed, hence planting is done smoothly and accurately.

#### 3.4. Seed sowing disc & seed bucket

The disc which is attached at the bottom of the tank allows one seed during one rotation of the wheel. In the above figure, the seed sowing disc is also included as shown in figure 6. The buckets are screwed onto the disc. These buckets are very similar to the half-shape of Pelton buckets. As they are screwed to the disc, their size is varied according to the diameter of the seed and the required distance between the seeds.



Fig.6 Seed sowing disc & seed bucket

#### 3.5. Power transmission mechanism

Power transmission is done by a belt and pulley transmission system. Here, different pulleys are used for speed variation to get a variable distance between two seeds. The belt is shifted from one pulley to another to achieve the required distance between two seeds. The main power of the machine is available from the wheels of the machine. Once a person pushes the machine, the wheels rotate according to the speed of the machine. The wheels transmit power through the power transmission mechanism as shown in figure 7.



Fig.7 Power transmission mechanism

## 4. DESIGN OF COMPONENTS

### 4.1. Design of Belt-pulley

The Belt-Pulley are mostly used to transmit motion and power from one shaft to another. When the center distance between their shafts is short as shown in figure 8.

The Speed (velocity) ratio (S.R.) of a Belt-Pulley drive is given by

$$S.R. = \frac{n}{N} = \frac{D}{d}$$

Where,

$N$  = Speed of rotation of bigger pulley in rpm,  
 $n$  = Speed of rotation of smaller pulley in rpm,

$d$  = diameter on the smaller pulley in mm,

$D$  = diameter on the larger pulley in mm

$S.R. = \frac{n}{N} = \frac{100}{62.5} = 1.6$

$n = 62.5$  rpm

$N = 2540$  rpm

The average velocity of the belt is given by

$$V = \frac{\pi DN}{60}$$

Where  $D$  = diameter of bigger pulley in mm,

and  $N$  = Speed of rotation of bigger pulley in rpm,

Velocity ratio =  $\frac{D}{d} = \frac{100}{40} = 2.5$

B.Length of Belt and Centre Distance

Let  $d$  = diameter on the smaller pulley in mm

$D$  = diameter on the larger pulley in mm.

motion by the single slider crank mechanism, due to this arrangement the connecting rod moves upward and downward which then reciprocate the piston of the single acting reciprocating pump mounted at the top of the storage tank. The Block diagram of the proposed system is shown in figure 9.

During the upward motion of the connecting rod the pesticide is drawn into the pump and during the downward motion of connecting rod the pesticide is forced to the delivery valve, the delivery is connected to the pipe carrying the number of nozzles. Improved seed-cum-seed drills are provided with seed and seed boxes, metering mechanism, furrow openers, covering devices, frame, ground drive system and controls for variation of seed and seed rates.

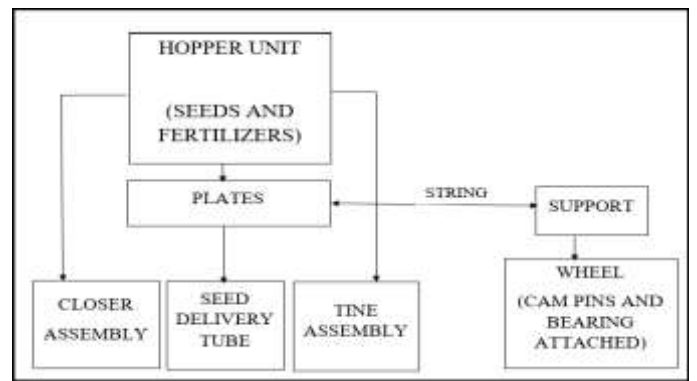

Fig.9 Block diagram of the proposed system

### 5.1. Advantages of machine

Following are the advantages of manual seed planter machine are

- Improved efficiency in planting.
- Increased yielding and reliability in crop. Increased cropping frequency.
- Increased speed of seed planting.
- Seed planting accuracy.
- Durable and cheap as low cost materials are used.
- Less maintenance cost.
- Since seed can be poured at any required depth, the plant germination is improved.
- Dependency on labour also decreased. Also it saves time of sowing.
- Uniform placement of seeds in row with required distance.
- Proper compaction over the seeds is provided.
- It maintains the proper row spacing.
- The seeds can be placed at proper depth.
- Seed rate can be controlled.
- Many seeds can be sown by this machine.
- Due to small size machine is portable. And can also be used in small area.
- Cost efficient.
- Improve agricultural soil carbon sequestration.
- Save energy, money and time of a farmer.

## 5. WORKING PRINCIPLE

When the equipment is pushed forward by using handles, the front wheel rotates and the gear is mounted on the axle of the wheel is start to rotate and its rotation is then transferred to the pinion through the chain drive. The rotary motion of the pinion is converted into the reciprocating

## 5.2. Disadvantages of machine

- Suitable for small Farms Only.
- Difficult to operate in moist condition.
- It will use man power to drive the machine.

## 5.3. Application

- It use in agriculture for seeds sowing with fixed distance and with more accuracy.
- Also it is used for gardening purpose.

## CONCLUSIONS

Innovative Seed sowing equipment's has remarkable influence in agriculture. By using this innovative project of seed sowing equipment we can save more time required for sowing process and also it reduces lot of labourer cost.

It is very helpful for small scale formers as it weighs less.

After comparing the different method of seed sowing and limitations of the existing machine, it is concluded that the this seed sowing machine can

- Maintain row spacing and controls seed rate.
- Control the seed depth and proper utilization of seeds can be done with less loss.
- Perform the various simultaneous operations and hence saves labour requirement so as labour cost, labour time and also save lots of energy

Hence it is easily affordable by farmers. So we feel that this project serves something good to this world and we would like to present it before this prosperous world.

## REFERENCES

- [1] Adisa A F, Braide F. G, "Design and Development of Template Row Planter", Transnational Journal of Science and Technology, vol. 2, No.7, 2012.
- [2] Rolando P, Automatic Seed Planter Punching Type", "International Journal of Emerging Technology & Research Volume 1, Issue 3, (www.ijetr.org) ISSN (E): 2347-5900 ISSN (P): 2347- 6079. Mar-Apr, 2014.
- [3] P.P. Shelke:-"frontline demonstration on bullock-drawn planter enhances yield of soya bean crop." International journal of farm science 1(2):123-128, 2011.
- [4] Mahesh R. Pundkar":- "A seed sowing machine: A review" IJESS volume 3, Issue 3. ISSN: 2249-9482, International journal of engineering and social science.
- [5] Enhanced agriculture robotic system" by Mr.Sagar R. Chavan, Prof. Rahul D. Shelke, Prof. Shrinivas R. Zanwar, International journal of engineering sciences & research technology, ISSN: 2277-9655 Scientific Journal Impact Factor: 3.449 2015.
- [6] shivaraja kumar. a1, parames waramurthy, Design and development of wheel and pedal operated sprayer" by, Volume 2, Issue 6, June 2014.
- [7] Kyada, A. R1\*, Patel, D. B., Design and development of manually operated Seed planter machine" , 5th International & 26th All India Manufacturing Technology, Design and Research Conference (AIMTDR 2014) December 12th-14th, 2014.
- [8] Aditya Kawadaskar1, Dr. S. S. Chaudhari2, Aditya Kawadaskar, Review of methods of seed sowing and concept of multi-purpose seed sowing machine" by, IJPRET, 2013; Volume 1(8): 267-276, ISSN: 2319-507X.
- [9] Mahesh. R. Pundkar and A. K. Mahalle, "A Seed-Sowing Machine: A Review" International Journal of Engineering and Social Science, Volume3, Issue3, Pp-68-74
- [10] Laukik P. Raut, Smit B. Jaiswal and Nitin Y. Mohite, "Design, development, and fabrication of agricultural pesticides. with weeder", International Journal of Applied Research and Studies, Volume 2, Issue 11, Pp-1-8. 2013.
- [11] D. Ramesh and H. P. Girishkumar, "Agriculture Seed Sowing Equipment: A Review", International Journal of Science, Engineering and Technology Research, Volume 3, Issue 7, Pp-1987-1992, 2014.
- [12] Pranil V. Sawalakhe, Amit Wandhare, Ashish Sontakke, Bhushan Patil, Rakesh Bawanwade and Saurabh Kurjekar, "Solar Powered Seed Sowing Machine", Global Journal of Advanced Research, Vol-2, Issue-4, Pp-712-717 .
- [13] Sridhar H .S "Development of Single Wheel Multi-Use Manually Operated Weed Remover", International Journal of Modern Mahesh. R. Pundkar and A. K. Mahalle, "A Seed-Sowing Machine: A Review" International Journal of Engineering and Social Science, Volume3, Issue3, Pp-68-74
- [14] Laukik P. Raut, Smit B. Jaiswal and Nitin Y. Mohite, "Design, development, and fabrication of agricultural pesticides. with weeder", International Journal of Applied Research and Studies, Volume 2, Issue 11, Pp-1-8, 2013.
- [15] D. Ramesh and H. P. Girishkumar, "Agriculture Seed Sowing Equipment: A Review", International Journal of Science, Engineering and Technology Research, Volume 3, Issue 7, Pp-1987-1992, 2014.
- [16] Pranil V. Sawalakhe, Amit Wandhare, Ashish Sontakke, Bhushan Patil, Rakesh Bawanwade and Saurabh Kurjekar, "Solar Powered Seed Sowing Machine", Global Journal of Advanced Research, Vol-2, Issue-4, Pp-712-717
- [17] Sridhar H .S "Development of Single Wheel Multi-Use Manually Operated Weed Remover", International Journal of Modern
- [18] Prasanna Raut, Pradip Shirwale, Abhijeet Shitole "A Survey On Smart Farmer Friendly Robot Using Zigbee", International Journal of Emerging technology and Computer Science, Volume: 01, Issue: 01, February 2016.
- [19] Calvin Hung, Juan Nieto, Zachary Taylor, James Underwood and Salah Sukkarieh, "Orchard Fruit Segmentation using Multi-spectral Feature Learning", IEE/RSJ International Conference on

Intelligent Robot System Tokyo, Japan, 3-7, November 2013.

- [20] Shrinivas R. Zanwar, R. D. Kokate, "Advanced Agriculture System", International Journal of Robotics and Automation (IJRA), Vol. 1, No. 2, pp. 107~112, June 2012.
- [21] Swetha S. and Shreeharsha G.H., "Solar Operated Automatic Seed Sowing Machine", Cloud Publications International Journal of Advanced Agricultural Sciences and Technology 2015, Volume 4, Issue 1, pp. 67-71, Article ID Sci-223, 26 February 2015.
- .