

# Design of Diagnosis Device for Electronic Throttle Body

Dolly M N<sup>1</sup>, Vibha Damodara Kevala<sup>2</sup>

<sup>1</sup>Dept. of Mechatronics Engineering, Manipal Academy of Higher Education, Manipal, India

<sup>2</sup>Assistant Professor, Dept. of Mechatronics Engineering, Manipal Academy of Higher Education, Manipal, India

\*\*\*

**Abstract** - This paper introduces a new portable device for diagnosing the electronic child parts of Electronic Throttle Body. The complete device is the combination of hardware and software where the sensor output will be processed and displayed on the screen and by using driver circuit the motor is made to rotate and check the operation of motor and sensor.

**Key Words:** Electronic Throttle Body, ECU, microcontroller, PWM, LCD.

## 1. INTRODUCTION

In recent years, internal combustion engines are predominantly used in automobile application. Torque and power output of the engine must be controlled according to the requirements as the car does not need to use the maximum engine power in many circumstances. Throttle valve is one of the important components of the engine that controls the amount of air to be supplied in the intake manifold and power output of the engine. It regulates the amount of air mass flow into the combustion chamber. The amount of air flow into the chamber depends upon the throttle plate position. Due the existence of multiple non smooth nonlinearities, the controller designed to electronic throttle body becomes difficult task. These nonlinearities include stick-slip friction, backlash and a discontinuous non-linear spring involved in the system. In trying to keep up with emissions and fuel efficiency laws and also the upcoming BS6 norm, the fuel systems used in modern cars has changed a lot over years. One of the major components in an automobile engine is the throttle valve part[1].

The electronic throttle body is installed in the intake manifold of the engine via a harness connector and connected to the electronic control unit[2]. It consists of the housing and the throttle plate, direct current motor to provide movement for the plate, gears to maintain the required torque, position sensor to measure the throttle plate position and the connector for connection to the control unit. The throttle plate is fixed on the shaft of the throttle body. As the motor is powered, it tends to rotate and makes the throttle shaft and plate rotate. The position of the plate is measured by the hall sensor and provides the output voltage for the corresponding angle of rotation of the throttle plate. In case of emergency (cable break, emergency shut-off) the throttle plate returns to default position[3].

Next section gives an idea about system level working of electronic throttle body. Section 2 briefly explains about the

proposed methodology of the system. Section 3 will concludes about the topic.

## 1.1 SYSTEM LEVEL WORKING

The electronic throttle body is installed in the intake manifold of the engine via a harness connector and connected to the electronic control unit. It consists of the housing and the throttle plate, direct current motor to provide movement for the plate, gears to maintain the required torque, position sensor to measure the throttle plate position and the connector for connection to the control unit. The throttle plate is fixed on the shaft of the throttle body. As the motor is powered, it tends to rotate and makes the throttle shaft and plate rotate. The position of the plate is measured by the position sensor and provides the output voltage for the corresponding angle of rotation of the throttle plate. In case of emergency (cable break, emergency shut-off) the throttle plate returns to default position.

In diesel engine, the closed loop system involves the same components as the petrol engine, but here instead of direct connect from the accelerator pedal the engine's exhaust pressure difference will be the trigger for the ECU. Based on the output of the pressure sensor placed at the exhaust of the engine, the throttle plate will move. This part is helps to clean the regenerator filter which will be placed at the exhaust. If any particles are stuck in the filter, there exists pressure difference before and after the filter so this will be sensed by the sensor and ECU will feed the PWM signal to motor and throttle plate will close completely hence temperature and pressure raise at the inlet of the filter which makes the particles go out of the filter and again pressure will be dropped and again signal goes and plate will go to normal position [4].

## 2. PROPOSED METHODOLOGY

To diagnose the sensor and motor operation of ETB, series of operation has to be performed from input AC supply to displaying the sensor value on the screen and also to obtain clock and counter-clock rotation of pate, that is, rotation of motor.

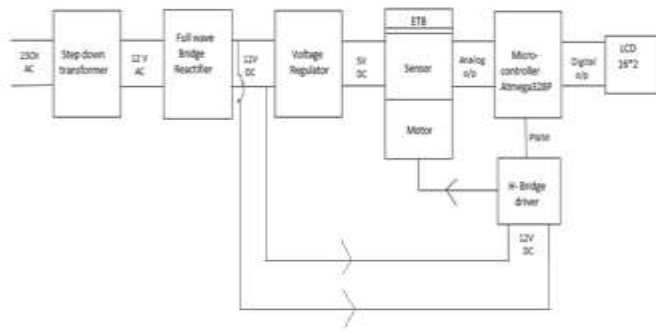

Fig -1: Block diagram of the system

The steps involved are represented in the Fig.1:

- First step is to step down the inputted 230V AC to 12VAC supply by using step down transformer.
- The step down AC supply must be converted into DC supply with the help of full wave bridge rectifier with capacitors and resistor filter in order to achieve less ripple DC output. The reason for full wave bridge rectifier is that, we need to rectify complete positive and negative cycles to be converted into DC also this converted DC will have more efficiency due to bridge circuit.
- The required input voltage for the sensor is 5V, so voltage regulator is used to provide this voltage for the sensor to operate properly and to measure the throttle plate position and provides the plate position in terms of analog voltage.
- This analog output from the sensor is fed to the analog input pin(s) to the controller and the controller will process this analog data as per the program inside the controller and convert into digital form which can be easily printed on the screen [5].

The logic of converting to digital value is,

$(\text{System voltage} * \text{Analog reading}) / \text{Resolution of ADC}$

- ✓ System voltage is the sensor input voltage which is equal to 5V.
- ✓ Analog reading is the analog output from the sensor which is fed to the input pin of controller.
- ✓ Resolution of ADC is  $2^{10} = 1024$ , 1024 discrete level and range is from 0 to 1023. Hence resolution is equal to 1023.
- ✓ Therefore, digital output is equal to  $(5 * \text{Analog value}) / 1023$ .
- So this converted voltage is transferred to LCD display via display lines and displayed on the LCD screen.

- The voltage obtained in the above step is the value of the throttle plate at default position since the motor is not made to rotate; the plate will be in default position.
- In order to drive the electrical motor, a driver circuit is needed and to operate in both directions, an H- bridge circuit is used which includes combination of MOSFETs and transistors. The supply voltage to driver is 12V which is taken from the bridge rectifier out and the speed of the motor is controlled by PWM signal from micro-controller.
- As the motor rotate correspondingly the throttle plate rotates and the sensor output voltage will be updated in the display.

At default position the voltage which is displayed on the LCD must be compare with the specified value. If the value displayed is within the tolerance limit then the sensor is working properly. Then, should make the plate to rotate to either of the mechanical stops with the help of motor, and can diagnose visually by checking the plate position. If it is in proper position then the motor is working properly, and again should check the updated sensor value on the screen and compare with tolerance limit, if it is within the limit then the sensor is working properly else there might be issue in sensor.

Logic inside the micro-controller involves initialization part, display part and input to driver circuit part. Firstly LiquidCrystal library is initialized which allows the micro-chip to control the liquid crystal display. Then the pins of the chip have to be initialized for LCD pins, these pins which are assigning to the LCD are enable, register select and data lines. Next is initializing variables for operation, the sensor output to the pin of controller chip and full close and full open position pins. Then the sensor pins has to be read and stored into one variable and as per the formula the sensor voltage is converted into digital value and transfer into LCD to display. Monitor full close and full open position pins and next involves the four conditions. Based on the conditions, following operation has to be performed and again the loop continuous from reading the sensor values.

### 3. CONCLUSIONS

The main objective of this paper is to diagnose the electronic sensor and motor of ETB. To achieve this basic idea is to display the sensor value on the screen at default, and both mechanical stops and verify whether it is working properly or not. And motor is visually verified when the plate is made to rotate to full open and full close positions.

In short, the preliminary diagnosis of electrical parameters of electronic throttle body that is, sensor and motor is been focused and the sensor values can be displayed on the screen with the help of micro-controller, where the sensor input will be processed and displayed to check for the

working of the sensor, and motor in turn throttle plate is made to rotate by using driver circuit.

#### REFERENCES

- [1] Mckay, D., Nichols, G., & Schreurs, B. (2000). Delphi Electronic Throttle Control Systems for Model Year 2000 ; Driver Features, System Security, and OEM Benefits . ETC for the Mass Market, (724).
- [2] Guo-feng, C., & Jin-hua, W. (2011). EGR control and simulation about EGR rates influence on diesel engine operation performance. 2011 International Conference on Electric Information and Control Engineering, 354–358. <https://doi.org/10.1109/ICEICE.2011.5777497>
- [3] Loh, R. N. K., Thanom, W., Pyko, J. S., & Lee, A. (2013). Electronic Throttle Control System : Modeling, Identification and Model-Based Control Designs, 2013(July), 587–600.
- [4] Wang, T., & Lin, X. (2010). Research in fuel injection revision control of gasoline engine based on the electronic throttle during transient condition. 2010 International Conference on Computer, Mechatronics, Control and Electronic Engineering, 3, 285–287. <https://doi.org/10.1109/CMCE.2010.5610328>
- [5] Badamasi, Y. A. (2014). The Working Principle Of An Arduino. 2014 11th International Conference on Electronics, Computer and Computation (ICECCO), 1–4. <https://doi.org/10.1109/ICECCO.2014.6997578>