

# KINEMATIC DESIGN METHODOLOGY OF VERTICAL COIL TONG

Mr. RAHUL M<sup>1</sup>, Dr. NATARAJ J R<sup>2</sup>

<sup>1</sup>M.Tech Student, Dept. of Mechanical Engineering, RV College of Engineering, Karnataka, India

<sup>2</sup>Associate Professor, Dept. of Mechanical Engineering, RV College of Engineering, Karnataka, India

\*\*\*

**Abstract** – Vertical Coil Tong (VCT) is a material handling equipment used for lifting heavy steel coil vertically. The design methodology and gripping force to lift the coil is unknown for VCT, this leads to slippage of coil and leads to coil damage and loss of human life in plant. In the present work the design methodology has been developed to calculate the Gripping force and forces in joints of VCT using static force-moment equilibrium equations. A 5-ton capacity VCT is modelled in CATIA V5 and structural analysis carried out in ANSYS17.2 for three usage condition namely self-weight, VCT holding 900mm OD coil and 1300mm OD coil. Since the VCT is over designed and weight reduction has been carried out and overall weight of VCT has been reduced by 4.81%.

**Key Words:** Vertical Coil Tong, Equilibrium equations, Gripping Force, Material- SAILMA 350, En 24, CATIA V5, Ansys 17.2

## 1. INTRODUCTION

Iron and steel industries have a great demand for material handling equipment for lifting and transporting the bulk material from one place to another within a plant. There are various mechanism and equipment used for lifting, where VCT is one of the primary equipment used for vertical lifting of coil this will help the worker in plant where the human intervention is avoided due to hot roll mills, the VCT is mechanically operated and no need of any electric, hydraulic etc. The VCT is lifted by either by overhead crane or mobile crane depending upon the application of lifting the coil. The VCT is provided with two four-bar parallelogram mechanisms to maintain the unison direction while lifting.

There are many research work carried out on lifting equipment. Gerald et al [1] explains the approach to analyze the forces in linkages using Static equilibrium equation which states the Newton's first two law that "sum of all forces acting on body must be zero, if body is at rest". Force Analysis in tongs can be carried out by drawing free body diagram of each link [2]. This paper has adopted ASME BTH 30.20 to know the grip ratio of the tong. ASME BTH 30.20 states that for a safe lifting of a

load the friction force should be less than multiple of coefficient of friction and force normal surface i.e.,  $F_R < Nf_0$ . The force in joints are calculated by equilibrium equation for bracket assembly coil holding [3] Y Zhongjun [4] et al modelled the vertical coil tong in Pro/E and imported to Adams Software to

Define the various constraints involved in model such as spherical joint, revolute joint, Cylindrical joint and contact force imposed between outer jaw and the steel coil the simulation results shows that as increase in the diameter of steel coil the clamping force increases which effect the stress state of steel coil near the jaw. Viswanathan et al [5] modelled a lifting tong in CATIA V5 and meshed the model in HYPERMESH using brick elements to obtain the accurate results which was initially surface meshed and converted to three dimensional mesh and solved in ANSYS the results shows the von-Mises stress developed is within the limit and using optimal design in software the overall design weight was reduced to 28%.Abdur et al [6] carried out analysis for self-weight of tong as many structures fail initially and optimized the design stress for each part using finite element software ANSYS.

A literature shows that mechanism and strength of lifting equipment are more concentrated and no or very few works on gripping force and forces in joints, hence in present work the design methodology has developed to calculate the Gripping force and forces in joints of VCT using static force-moment equilibrium equations and check is design is safe or not the structural analysis has been carried out.

## 2. OBJECTIVES

- Formulation of a design methodology for single rim vertical coil tong to lift heavy steel coil with adequate strength.
- Calculation of the forces in joints of vertical coil tong using force-moment equilibrium equation
- Calculation of the gripping force for the vertical coil tong.
- Structural Analysis of Vertical Coil tong with and without Coil.
- Reduction of the tong weight from overdesigned.

### 3. FORCE ANALYSIS DESIGN METHODOLOGY

Initially the free body diagram of VCT is drawn where the forces in joints are represented in Fig-1 using force-moment equilibrium equation the forces in joints and gripping forces are calculated. These calculated gripping force shows that 2.76 times the load lifted which is acceptable for lifting the heavy steel coil. Here lengths L1, L2, L3, L5, L6, L7, L8, L9 and angle  $\alpha$  are known and force F1, F2, F3, F4, F5,  $F_R$  and  $F_x$  are unknown parameters, these parameters can be determined by using the developed force design methodology which can be further used in structural analysis of VCT with and without coil.

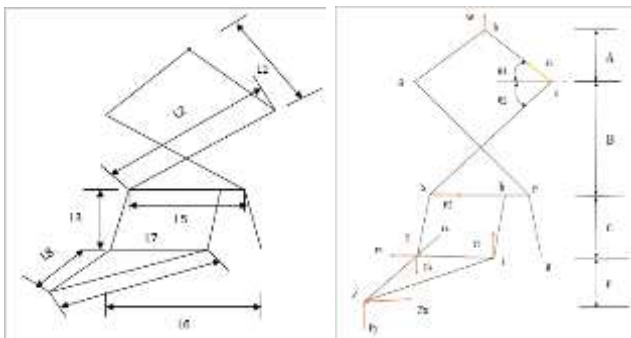

Fig-1: Free body Diagram of VCT

Table -1: Forces in joints of VCT holding 900 mm OD Coil

Forces	Magnitude (KN)
F1	24.19
F2	93.47
F3	106.52
F4	17.57
F5	39.04
$F_R$	99.00
$F_y$	17.57
$F_x$ (Gripping force)	97.65

Table-2: Forces in joints of VCT holding 1300 mm OD Coil

Forces	Magnitude (KN)
F1	38.76
F2	149.78
F3	170.69
F4	28.31
F5	158.64
$F_R$	62.53
$F_y$	28.31
$F_x$ (Gripping force)	156.48

The above Table-1 and Table-2 shows the forces in joints and Gripping force of 5-ton capacity VCT holding 900 mm OD and 1300 mm OD coil respectively.

### 3. MATERIAL PROPERTIES OF VCT

Table -3: Mechanical Properties of Materials

Material	Density (kg/m <sup>3</sup> )	Young's Modulus (MPa)	Yield Strength (MPa)	Ultimate Strength (MPa)
SAILMA 350	7850	210	320	490
En 24	7850	210	650	850

The Mechanical Properties of Materials are shown in Table-3

The SAILMA 350 material used for linkages of VCT and En24 is used for pins of the VCT which is very strong in nature.

### 4. MODELLING OF VCT

The modelling of VCT with and without coil is done in CATIA V5 by bottom-up assembly method, the diameter of coil chosen for modelling is 900 mm OD and 1300 mm OD with constant ID and width of 450mm and 400mm respectively.

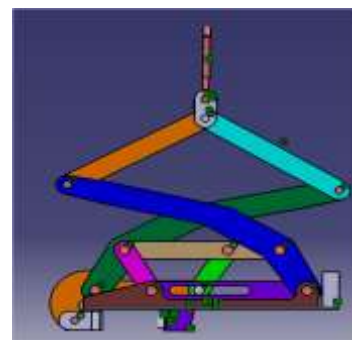

Fig-2: Front view of VCT without Coil

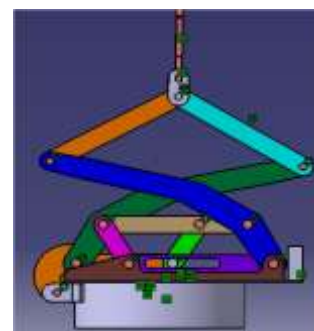
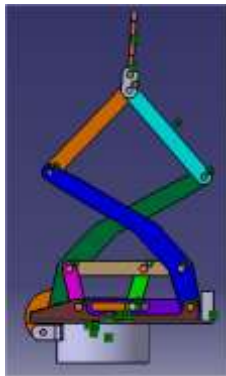

Fig-3: Front view of VCT holding 1300 mm OD coil



**Fig-4:** Front view of VCT holding 900 mm OD coil

Fig-2 shows the VCT without coil, Fig-3 shows the VCT holding 1300 mm OD coil and Fig-4 shows the VCT holding 900 mm OD coil. These assembly are done by bottom-up assembly method in CATIA V5 Software.

### 5. STRUCTURAL ANALYSIS OF VCT

The structural analysis of VCT for three usage conditions namely self-weight, VCT holding 900mm OD coil and 1300mm OD coil are carried out in ANSYS 17.2. To carry out analysis the models prepared in CATIA V5 are converted into stp file format to give input to ANSYS 17.2

#### 5.1 MESHED MODEL OF VCT

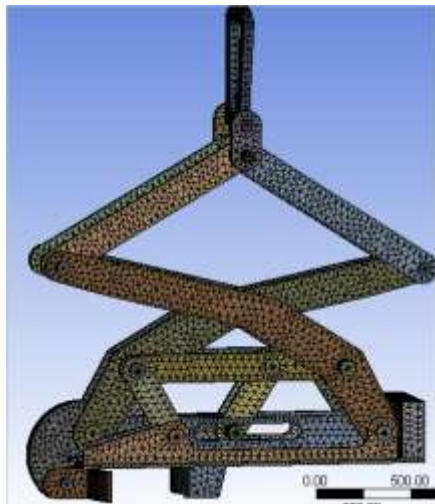

**Fig -5:** Meshed Model of VCT

Fig-5 shows the meshed model of VCT, the element type selected is SOLID 187 and tetrahedron mesh with element size of 20 mm the nodes and elements are 71796 and 32913 respectively. Similar conditions are followed to VCT holding 900mm and 1300 mm OD coil. The nodes and elements of VCT Holding 900mm OD coil are 174630 and 87493 respectively, The nodes and elements of VCT Holding 1300mm OD coil are 189175 and 96182 respectively.

#### 5.2 BOUNDARY CONDITIONS APPLIED

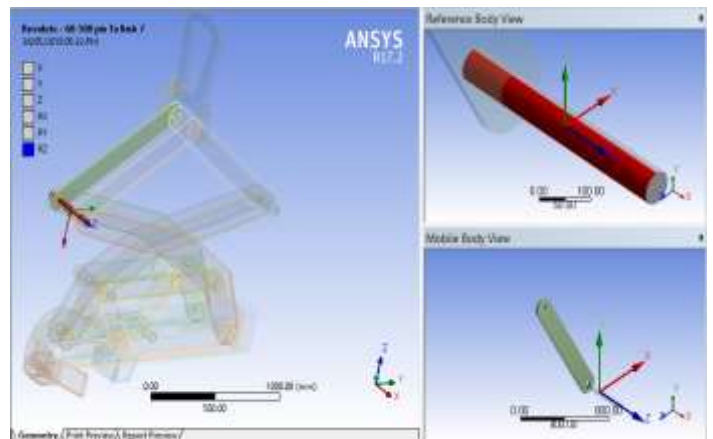

**Fig -6:** Revolute joint between pin and linkage

Revolute joint between pin and linkage is shown in Fig-6, where the rotation at z-axis is set free and all other directions are fixed which allows the link to move around the pin

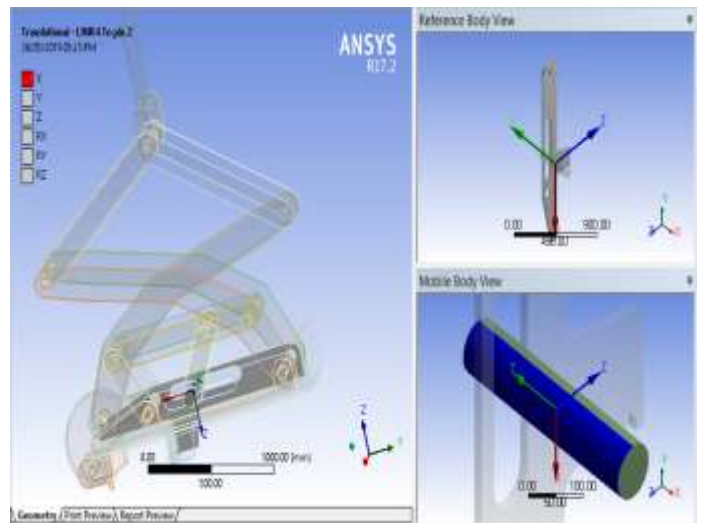

**Fig -7:** Translational joint between pin and linkage

The boundary condition applied in Fig-7 is the Translational joint between pins and linkages where only one direction X is set free to slide along the linkages and remaining five directions are fixed, there are two translational joints in the structure.

The self-weight force applied on VCT is 14.12 KN shown in Fig-8 which is applied on suspension bale represented as point A, addition to its two fixed support are provided representing B and C for outer pad and inner pad respectively, by applying the above boundary condition the structure is ready to solve.

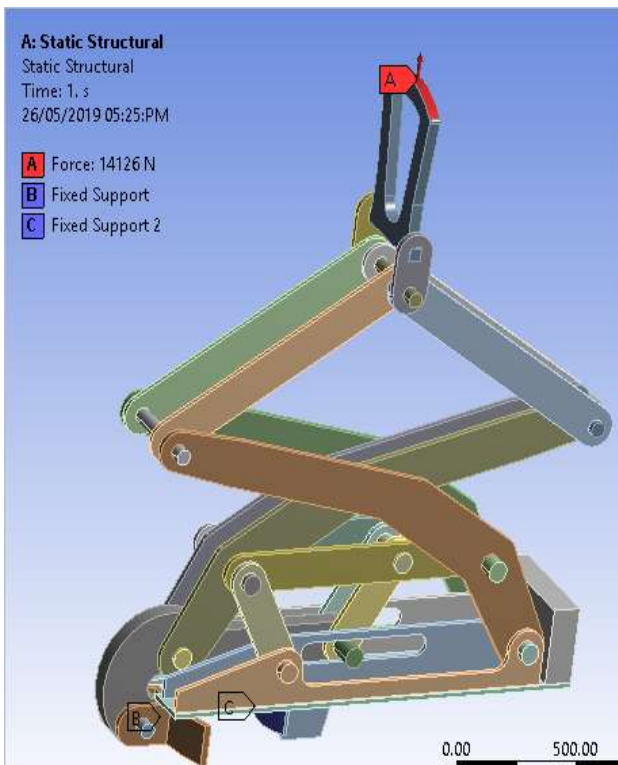

**Fig -8:** Force and support applied on VCT

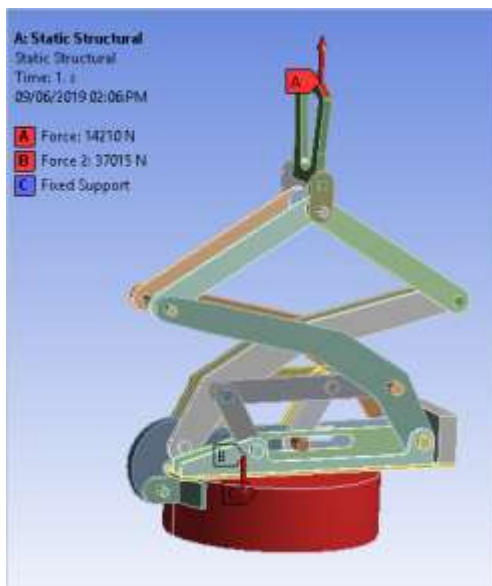

**Fig-9:** Boundary Condition applied to VCT holding 1300 mm OD Coil

Fig-9 shows the Boundary Condition applied to VCT holding 1300mm OD Coil, the self-weight is applied at suspension bale at point A, Coil weight is applied on coil at point B i.e., 37.015 kN and one fixed support at inner pad of the VCT.

The Boundary Condition applied to VCT holding 1300 mm OD Coil is similar to VCT holding 900 mm OD Coil only the

magnitude of coil weight is varied. The magnitude of coil weight of 900mm OD Coil is 15.75 kN

### 5.3 STRESS ON VCT

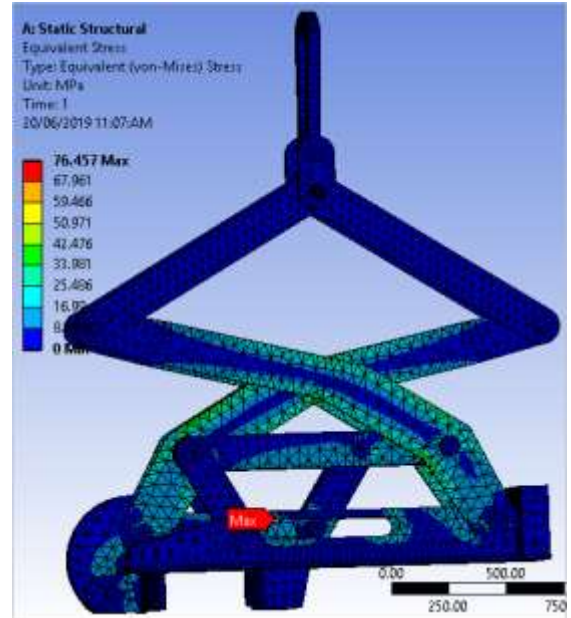

**Fig 10-** Stress plot of VCT for Self-weight analysis

The Stress plot of VCT is shown in Fig-10, where the maximum Equivalent Stress is 76.45 Mpa on J-link of the VCT and minimum stress is on counter weight the stress value shows that it is less than the yield stress hence the design is safe

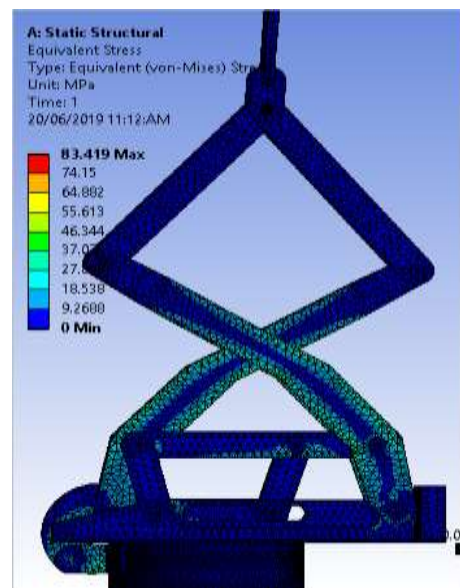

**Fig 11-** Stress plot of VCT holding 900mm OD Coil

The Stress plot of VCT holding 900 mm OD coil is shown in Fig-11, where the maximum Equivalent Stress is 83.41 MPa on J-link of the VCT and minimum stress is on counter

weight the stress value shows that it is less than the yield stress hence the design is safe

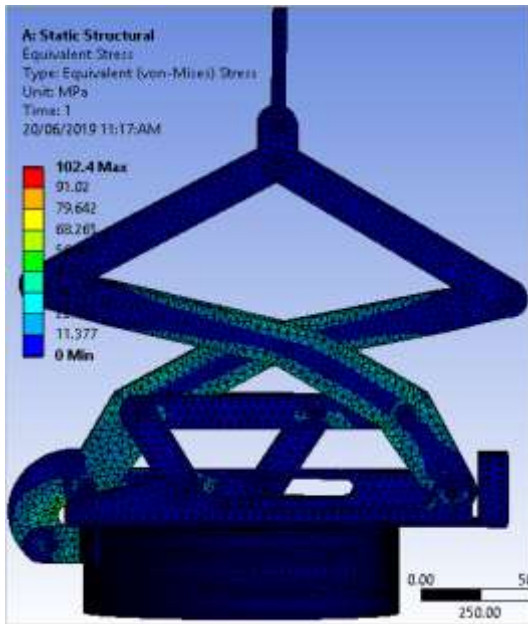

Fig 12- Stress plot of VCT holding 1300mm OD Coil

The Stress plot of VCT holding 1300 mm OD coil is shown in Fig-12, where the maximum Equivalent Stress is 102.4 MPa on J-link of the VCT and minimum stress is on counter weight the stress value shows that it is less than the yield stress hence the design is safe

### 6. WEIGHT REDUCTION OF VCT

The overall weight of vertical coil tong is 2000 kg, there is a possibility in reduction of weight hence the following trial and error approach has been adopted to reduce the weight.

The material used for linkages are SAILMA 350 plates, there are different standard size plates are available i.e., 16, 20, 25 and 63mm where for larger thickness these plates can be lapped. In the vertical coil tong the maximum thickness is of J-link 75mm and the counterweight as of J-link has been placed opposite to J-link, hence the number of kg reduced from J-link can be reduced in J-link

Table -4 Weight of J-link

Thickness (mm)	Weight (kg)
75	144.56
60	115.65
50	96.38
40	77.03

Table-4 shows the weight of J-link with respect to its thickness, Further the stress analysis carried out on J-link

of different thickness mentioned in Table. The stress analysis carried out for maximum loading condition of J-Link.

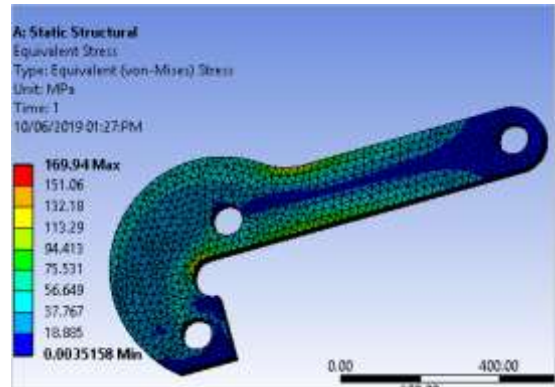

Fig-13: Stress plot of J-link, thickness =75mm

The maximum stress induced in J-link of thickness 75 mm is 169.94 MPa is shown in Fig-13

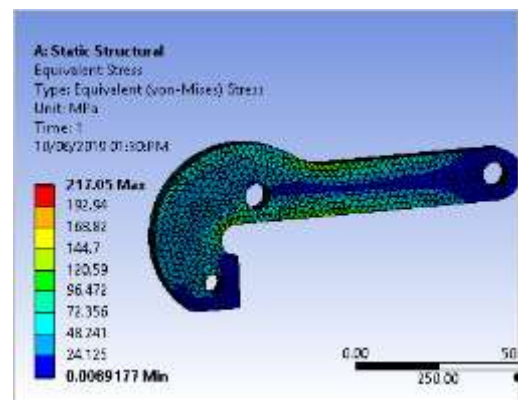

Fig-14: Stress plot of J-link, thickness = 60mm

The maximum stress induced in J-link of thickness 60 mm is 217.05 MPa is shown in Fig-14

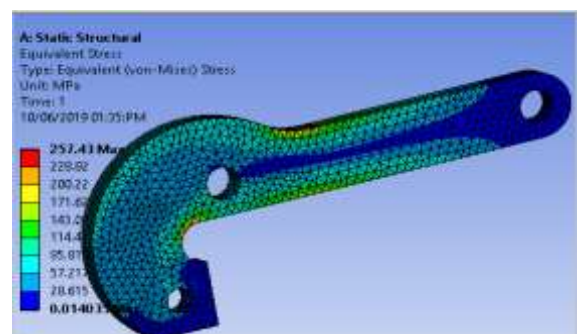
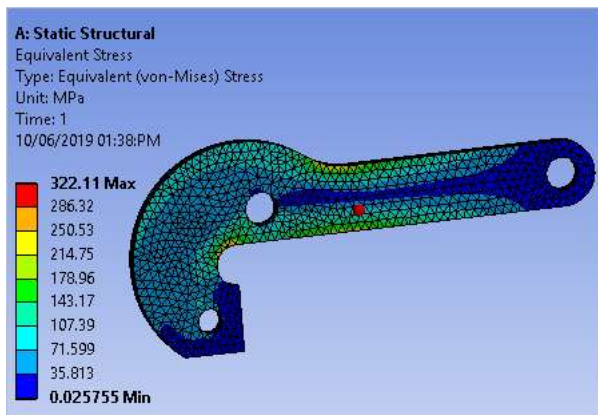

Fig-15: Stress plot of J-link, thickness = 50mm

The maximum stress induced in J-link of thickness 50 mm 257.43 MPa is shown in Fig-15



**Fig-16:** Stress plot of J-link, thickness = 40mm

The maximum stress induced in J-link of thickness 40 mm is 322.11 MPa is shown in Fig-16

From the above analysis of J-link it can be inferred that J-link of 75mm can be replaced by 50 mm thickness J-link which can reduce the weight of overall VCT

## 7. CONCLUSIONS

The Design and structural analysis of vertical coil tong has been carried out with different usage conditions and the following conclusion are drawn:

- The Gripping force developed by VCT holding 900 mm OD coil is 97.65 KN and the Gripping force developed by VCT holding 1300 mm OD coil is 156.48 KN
- The maximum stress induced in vertical coil tong for self-weight analysis is 76.47 MPa, VCT holding 900 mm OD steel coil is 83.41 MPa and VCT holding 1300 mm OD steel coil is 102.4 MPa
- The results of analysis shows that in all three usage condition of Vertical Coil Tong the maximum stress induced in VCT is less than the yield strength of material i.e., 320 MPa .
- The factor of Safety is 3.36 for tensile failure in lugs and Maximum Tensile loading 174.64 KN which is less than applied load, similarly the factor of Safety is 2.8 for Single plane fracture Strength in lugs and Maximum Tensile loading 153.75 KN which is less than applied load, which shows the design of lug is safe.
- Biggest member in the VCT is J-Link with thickness of 75 mm. The simulation confirmed the stress induced 50mm thickness J-link is within the yield strength of material SAILMA 350. This replacement resulted in overall reduction of VCT is 4.81 %

## 8. REFERENCES

- [1] Gerald Rothenhofer, Conor Walsh, Alexander Slocum "Transmission ratio based analysis and robust design of mechanism", Precision Engineering Vol 34 (2010) Pp 790 – 797
- [2] "Application Basics for lifting tong", Bushman Equipment Inc., 2012
- [3] Mukul Bhalekar, Ritesh Banapurkar, "Design, Analysis and Optimization of Heavy Metal Roll Lifting Bracket Assembly for Steel Industry: With Calculations", International Journal of Engineering Science and Computing, May 2016
- [4] Y Zhongjun, Tang Zhichao, Xiang Yang, "Simulation and Improving of the Behaviour of Automatic VCT for Steel coil Transferring", University of Science and Technology, Beijing China 2010
- [5] Vishwanth Kanal, Vinod Nirale, Ravindra Kondaguli, "Design, Analysis and optimization of lifting tong", International Journal of Research in Engineering & Advanced Technology, Vol 2, issue 4 sept-2014
- [6] Abdur Rahman, Shabbir Ahmed R.M, Dr. Mohamed Haneef, "Design and Structural Optimization of Grab Tong for Coil Wire Applications", International Journal of Innovative Research in Science, Engineering and Technology, Vol. 3, Issue 6, June 20
- [7] Frank Richardson, "Lifting Tongs," US Patents 1365196, Jan 21, 1921
- [8] Max R. Heppenstall, "lifting tongs", US Patents 2536932 January 2 1951
- [9] J W PICK "Attachments for lifting tong" US Patents 2790672 April 30, 1957
- [10] American Society of Mechanical Engineer, ASME BTH 30.20 2010
- [11] American Society of Mechanical Engineer, ASME BTH-1-2011
- [12] Engineering Mechanics Statics, Prentice Hall International Editions, 1974
- [13] Jingxin Wang ,Chris B. LeDoux ,Lihai Wang, "Modeling and Validating the Grabbing Forces of Hydraulic Log Grapples Used in Forest Operations" , International Journal of Forest Engineering, Vol 16 issue 1, Pp 77-85

[14] Jingxin Wang, "Effects of Tong Shapes on Hydraulic Log Grapple's Performance in Loading and Unloading Operations", International Journal of Forest Engineering, Vol 14 issue 1 Pp 59-66.

[15] G Manikandan, MBN Raju, "Root cause Analysis of Tong mark defect during material handling of IF steel coils" 5th International & 26th All India Manufacturing Technology, Design and Research Conference (AIMTDR 2014) December 12 Guwahati, Assam, India.

## 9. ACKNOWLEDGEMENTS

We would like to express our sincere thanks to the Management and design department officials of Yellow Stone Engineers India Private Limited, for imparting knowledge on Vertical Coil Tong, its function, actual usage conditions, and general design & analysis methodology.

## BIOGRAPHIES



RAHUL M  
M.Tech Machine Design  
Dept. of Mechanical Engineering  
RV College of Engineering@  
Karnataka, India



Dr. NATARAJ J R  
Associate Professor  
Dept. of Mechanical Engineering  
RV College of Engineering@  
Karnataka, India