

IMPLEMENTATION OF HEALTH MONITORING AND MOVEMENT OF HANDICAP VEHICL USING PIC MICROCONTROLLER

Ms. Chandralekha. R¹, Mr. Balaji Vignesh. L.K²

¹Dept. of Electronics and Communication Engineering, AAA College of Engineering and Technology, TN, India.

²Assistant Professor, Dept. of Electronics and Communication Engineering, AAA College of Engineering and Technology, TN, India.

Abstract - Here is implemented a home navigation system, which comprises of a wheelchair which works on the inputs such as gesture and voice commands via an android phone and navigates according to command. It can be used by an elderly or physically challenged person to move inside the home without any difficulty. It's common that the elders and the physically challenged people find it hard to move the wheel chair without external aid. By making use of HNS, elderly and the physically challenged can move to different locations in the particular house just by pronouncing the direction name or by making the movement of the android phone they will be provided with. It is also equipped with obstacle avoidance technique, where the person may not be able to provide proper command at the right time. A security threat message can be sent through the mobile phone to predefined number, if the user feels to be found in danger.

Key Words: Wheel chair, Sensors, Android phone, Health Monitoring.

1. INTRODUCTION

The most common image of disability is the people in wheelchairs. Wheelchairs are used by people who find themselves unequipped to move without external aid. The special needs of the elderly may differ from that of a physically challenged person or a large individual but they all have "special needs" and often require some assistance to perform their daily routine. The physically challenged people, who use a normal wheelchair for navigation, usually require an external person to move around. In this busy world, the elderly people may be left alone at home and also may not find an apt person for external help. Here comes the need of an automated home navigation system, which consists of a wheelchair which can be used by the elderly and the physically challenged people without the help of an external person. The proposed HNS can be operated using voices and the gestures of the provided android mobile phone. An important feature is that the personal security of the person who is using the wheelchair is also taken care. If the person feels uncomfortable or insecure, he can send a message to a predefined number using the speech to text (STT) function in the mobile phone.

1.1 EXISTING SYSTEM

Before you begin to format your paper, first write and save the content as a separate text file. Keep your text and graphic files separate until after the text has been formatted and styled. Do not use hard tabs, and limit use of hard returns to only one return at the end of a paragraph. Do not add any kind of pagination anywhere in the paper. Do not number text heads-the template will do that for you.

I. BLOCK DIAGRAM

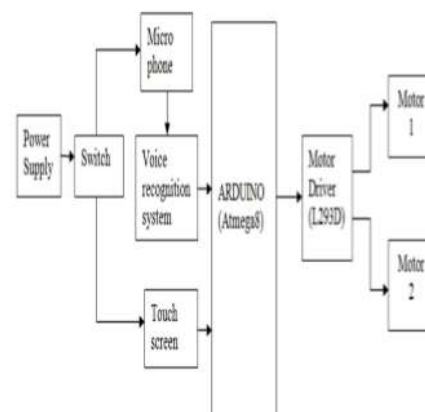

II. WORKING

In this system there are two input devices, speech recognition system and touch screen. In order to select a specific input device we are using a switch that is when the switch=1 voice recognition system is considered and when switch=0 touch screen is considered. The output of the touch screen is analog in nature, to digitize these signals we are using in-built six channel ADC of ATMEGA8 micro controller. On receiving the Signal the microcontroller directs the motors through the control circuit. In this, two DC brushless motors are used for controlling the two wheels of the chair independently. The different directions of motions possible are: □ Forward: Both the motors in the forward direction.

□ Backward: Both the motors in the reverse direction. □ Left: Left motor stopped/Right motor in the forward direction. □ Right: Right motor stopped/Left motor in the forward direction. The code is written in arduino such that the speed of the motors is controlled by using PWM output pins of

arduino. The motors are controlled with four different speed levels that is with 100% duty cycle, 75% duty cycle, 50% duty cycle, 25% duty cycle.

HARDWARE DESCRIPTION

A. HM2007 The voice recognition IC HM2007 is capable of operating in speaker independent speech recognition mode. In speech recognition mode, first, the voice is recorded to the external SRAM attached to the IC with the help of a directly connected microphone at the analog input terminal of HM2007 keeping the mode selection key in the record mode. In this way 40 0.9second long words or 20 1.92-second long words or phrases can be recorded into the memory. After training the voice recognition IC like above the mode selection key is switched to voice input mode. Here at a particular instant the speech through the microphone is compared with the recorded sound and according to that digital output is generated. The output of voice recognition IC is then fed to the digital input ports of the ATMEGA 8 microcontroller. The microcontroller on receiving the Signal directs the motors through the control circuit. The control of speed and direction are done in this way. The change of direction is achieved by changing the direction of current flow through the motor and speed control is achieved by varying the current through the motor. The Communication of HM2007 with microcontroller follows the protocol given below: 1. Microcontroller indicates on the S-bus that it is ready to receive the HM2007's status. 2. HM2007 indicates its status on the K-bus. 3. Microcontroller switches its pins connected to the HM2007's K-bus to inputs and reads status from the K-bus. 4. Microcontroller switches its pins connected to the HM2007's K-bus to outputs and writes a command to the Kbus. 5. Microcontroller indicates on the S-bus that the HM2007 should read the K-bus for a command. 6. HM2007 reads the K-bus for the command. 7. HM2007 responds to the command and places the results on the K-bus. 8. Microcontroller reads the K-bus to determine the result of the command.

B. Touch Screen Sensor

This is a 4-wire analog resistive touch screen. That is by touching the screen at one point, resistance between edges is formed for both the x and y axis. As you move your finger across the screen the resistance changes between opposite sides of each axis. By applying voltage across each axis, a change in resistance results in a change in voltage. Thus a simple ADC with a microcontroller can be used to find x and y positions. Add this touch screen to any LCD of requirement. Readings are taken by applying 5V across two of the pins and performing an analog to digital conversion on the other two pins. The full X and Y position can be achieved by using only 4 GPIOs.

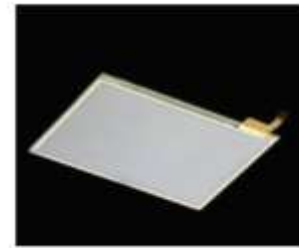

In this project we are using touch screen as an input device for the system. First we will observe the analog values for different positions on touch screen. Depending on these values complete touch screen module is divided into eight quadrants. Among them four quadrants are used for direction control that is for forward, backward, left and right. Remaining four are used for speed control where for each quadrant we will assign the duty cycle at receiver end. When we touch in 1st quadrant motor runs with 100% duty cycle, when we touch in 2nd quadrant motor runs with 75% duty cycle, when we touch in 3rd quadrant motor runs with 50% duty cycle, and when 4th quadrant is pressed motor runs with 25% duty cycle.

C. Arduino(ATMEGA 8) the microcontroller on the board is programmed using the arduino programming language and arduino development environment. Arduino programming provides a number of libraries to make programming easier. The most simplest of these are functions to control and read the I/O pins. In this project touch screen output is connected to analog pins of the arduino and the speech recognition sensor output is connected to the digital pins of the arduino. The arduino programming is written such that, based on the switch state the touch screen or the speech recognition sensor output values are processed and the direction and speed of the motors and thus the wheels are controlled through the motor driver circuit.



2. PROPOSED SYSTEM

- The Tongue Drive System allows handicapped users move around their wheelchairs.
- In addition to the vehicle control, also monitor the health conditions of the person using the vehicle.
- The output from these sensors are then given to microcontroller for further processing. If the

microcontroller finds any abnormality in the health condition of the handicap, it automatically sends SMS to the pre defined number stored in it. This is done with the help of GSM technology.

BLOCK DIAGRAM

TRANSMITTER:

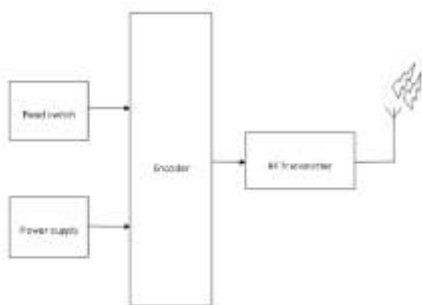

RECEIVER:

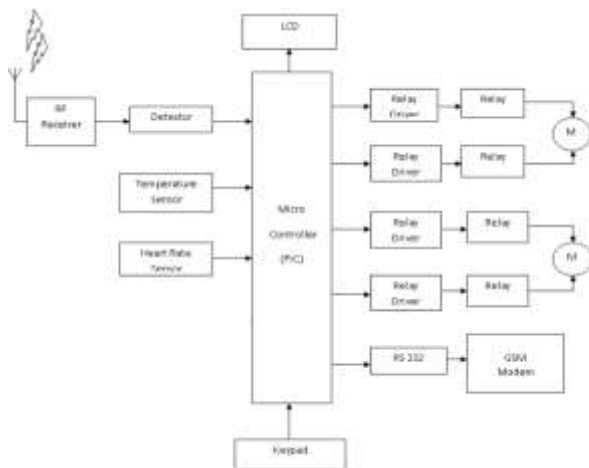

HARDWARE DETAILS AND DESCRIPTION

POWER SUPPLY DETAILS

The ac voltage, typically 220V rms, is connected to a transformer, which steps down the high ac voltage to low ac voltage. A diode rectifier then provides a full-wave rectified voltage that is initially filtered by a simple capacitor filter to produce a dc voltage. This resulting dc voltage usually has some ripple or ac voltage variation.

A regulator circuit removes the ripples and also maintains the same dc value even if the input dc voltage varies, or the load connected to the output dc voltage changes. This voltage regulation is usually obtained using one of the popular voltage regulator IC units.

WORKING PRINCIPLE:

TRANSFORMER:

The potential transformer will step down the power supply voltage (0-230V) to (0-6V) level. Then the secondary of the potential transformer will be connected to the precision rectifier, which is constructed with the help of op-amp.

MICROCONTROLLER:

A microcontroller is one that has microprocessor features together with internal memory, timer/counter, I/O ports etc. The main use of a microcontroller is to control the operation of a machine using a fixed program that is stored in ROM and that does not change over the lifetime of the system.

The microcontroller is a special purpose device. For example, the microcontroller chip in calculator performs the function of calculator alone, unless its internal programming is changed. The basic microprocessor had 71% of its total instructions as multi byte instructions. Each byte of a multi byte instruction must be fetched from program memory and each fetch takes time.

This results in longer program byte counts and slower execution time versus single byte instructions. But, the basic microcontroller has 62% of its total instructions as multi byte instructions. Hence the program is more compact and runs faster to accomplish similar tasks.

MICROPROCESSOR - HISTORY

- 4 bit microprocessor - Intel 4004
- 8 bit microprocessor - Intel 8008, 8080, 8085, Z80
- 16 bit microprocessor - Intel 8086, Z8000
- 32 bit microprocessor - Intel 80386, Intel 80486

MICROCONTROLLER - HISTORY

- 4 bit microcontroller - TMS 1000
- 8 bit microcontroller - 8048, 8051
- 16 bit microcontroller - MSP 430
- 32 bit microcontroller - C2000
- 64 bit microcontroller - TX4927TM

INTRODUCTION TO PIC:

The microcontroller that has been used for this project is from PIC series. PIC microcontroller is the first RISC based microcontroller fabricated in CMOS

(complementary metal oxide semiconductor) that uses separate bus for instruction and data allowing simultaneous access of program and data memory.

The main advantage of CMOS and RISC combination is low power consumption resulting in a very small chip size with a small pin count. The main advantage of CMOS is that it has immunity to noise than other fabrication techniques.

PIC (16F877):

Various microcontrollers offer different kinds of memories. EEPROM, EPROM, FLASH etc. are some of the memories of which FLASH is the most recently developed. Technology that is used in pic16F877 is flash technology, so that data is retained even when the power is switched off. Easy Programming and Erasing are other features of PIC 16F877.

SPECIAL FEATURES OF PIC MICROCONTROLLER:

CORE FEATURES:

- High-performance RISC CPU
- Only 35 single word instructions to learn
- Single cycle instructions except for program branches that have two cycles
- Operating speed: DC - 20 MHz clock input
DC - 200 ns instruction cycle
- Up to 8K x 14 words of Flash Program Memory,
Up to 368 x 8 bytes of Data Memory (RAM)
Up to 256 x 8 bytes of EEPROM data memory
- Pin out compatible to the PIC16C73/74/76/77
- Interrupt capability (up to 14 internal/external)
- Eight level deep hardware stack
- Direct, indirect, and relative addressing modes
- Power-on Reset (POR)

PIN DIAGRAM OF PIC 16F877:

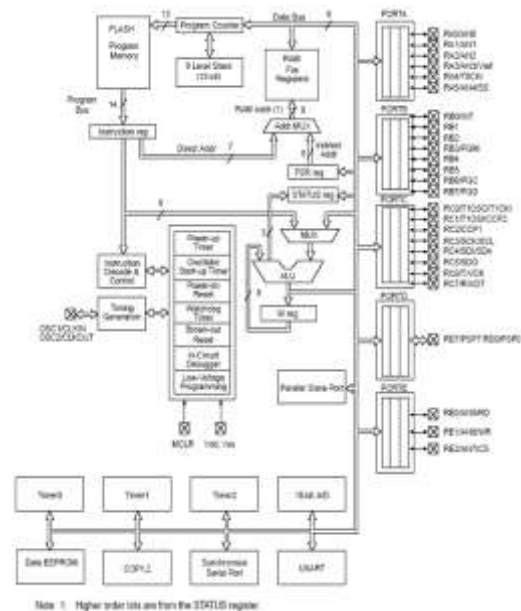
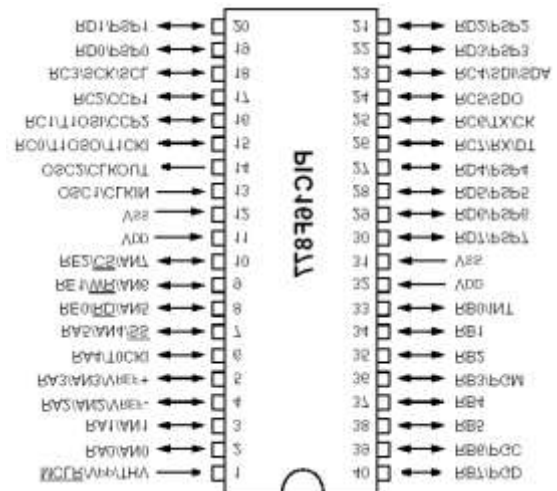

GLOBAL SYSTEM FOR MOBILE COMMUNICATIONS (GSM):

GSM (Global System for Mobile Communications), is a standard set developed by the European Telecommunications Standards Institute (ETSI) to describe protocols for second generation (2G) digital cellular networks used by mobile phones. It became the de facto global standard for mobile communications with over 80% market share.

Base station subsystem



GSM is a cellular network, which means that cell phones connect to it by searching for cells in the immediate vicinity. There are five different cell sizes in a GSM network—macro, micro, pico, femto, and umbrella cells.

The coverage area of each cell varies according to the implementation environment. Macro cells can be regarded as cells where the base station antenna is installed on a mast or a building above average rooftop level.

GSM Modem:

- **This GSM Modem can accept any GSM network operator SIM card and act just like a mobile phone with its own unique phone number.**
- **Advantage of using this modem will be that you can use its RS232 port to communicate and develop embedded applications. Applications like SMS Control, data transfer, remote control and logging can be developed easily.**
- **The modem can either be connected to PC serial port directly or to any microcontroller through MAX232. It can be used to send and receive SMS or make/receive voice calls.**



This GSM Modem can accept any GSM network operator SIM card and act just like a mobile phone with its own unique phone number.

Advantage of using this modem will be that you can use its RS232 port to communicate and develop embedded applications. Applications like SMS Control, data transfer, remote control and logging can be developed easily.

The modem can either be connected to PC serial port directly or to any microcontroller through MAX232. It

can be used to send and receive SMS or make/receive voice calls.

Features

- Status of Modem Indicated by LED
- Simple to Use & Low Cost
- On board switching type power supply regulator
- RS232 output

AT COMMANDS

Introduction

The following lists the AT control commands that a device is expected to support, however, a device may support more commands than listed.

For example, some phones support both AT+CGMI and AT+GMI commands to retrieve the manufacturer name.

In the future, additional commands from the GSM specifications 07.05 and 07.07 may be required, so it is recommended that all device manufacturers fully comply with GSM specifications.

The categories of control commands are:

- General Commands (GSM 07.07, Section 5)
- Call Control Commands (GSM 07.07, Section 6)
- Network Services Related Commands (GSM 07.07, Section 7)
- Mobile Equipment Control and Status Commands (GSM 07.07, Section 8)
- SMS Commands (GSM 07.05)
- Multiplexing Commands (GSM 07.10)
- Other Commands
- Phone-Specific Commands

General Commands (GSM 07.07, section 5)

Command	Description
AT+CGMI	Identify manufacturer
AT+CGMM	Identify model
AT+CGMR	Identify revision
AT+CGSN	Identify serial number (of device, not SIM card)
AT+CSCS	Select character set

Call Control Commands (GSM 07.07, section 6)

Command	Description
ATDnnn;	Dial "nnn" in voice mode.
ATH	Hangup the current call.
ATA	Answer an incoming call.

RS232

SERIAL COMMUNICATION:

Many PCs and compatible computers are equipped with two serial ports and one parallel port. Although these two types of ports are used for communicating with external devices, they work in different ways.

A parallel port sends and receives data eight bits at a time over 8 separate wires. This allows data to be transferred very quickly; however, the cable required is more bulky because of the number of individual wires it must contain. Parallel ports are typically used to connect a PC to a printer and are rarely used for much else.

A serial port sends and receives data one bit at a time over one wire. While it takes eight times as long to transfer each byte of data this way, only a few wires are required. In fact, two-way (full duplex) communications is possible with only three separate wires - one to send, one to receive, and a common signal ground wire.

- Bi-directional Communications
- Communicating by Bits
- The Parity Bit
- RS-232C
- DCE and DTE Devices
- 9 to 25 Pin Adapters
- Baud vs. Bits per Second
- Cables, Null Modems, and Gender Changers
- Cables Lengths
- Gender Changers
- Null Modem Cables and Null Modem Adaptors
- Synchronous and Asynchronous Communications

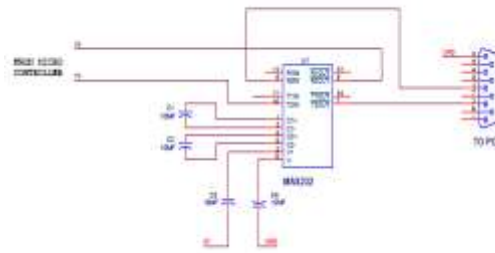

Circuit working Description:

In this circuit the MAX 232 IC used as level logic converter. The MAX232 is a dual driver/receiver that includes a capacitive voltage generator to supply EIA 232 voltage levels from a single 5v supply. Each receiver converts EIA-232 to 5v TTL/CMOS levels. Each driver converts TLL/CMOS input levels into EIA-232 levels.

Function Tables

EACH DRIVER

INPUT TIN	OUTPUT TOUT
L	H
H	L

H = high level, L = low level

EACH RECEIVER

INPUT RIN	OUTPUT ROUT
L	H
H	L

H = high level, L = low level

logic diagram (positive logic)

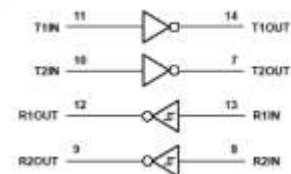

In this circuit the microcontroller transmitter pin is connected in the MAX232 T2IN pin which converts input 5v TTL/CMOS level to RS232 level. Then T2OUT pin is connected to receiver pin of 9 pin D type serial connector which is directly connected to PC.

In PC the transmitting data is given to R2IN of MAX232 through transmitting pin of 9 pin D type connector which converts the RS232 level to 5v TTL/CMOS level. The R2OUT pin is connected to receiver pin of the microcontroller. Likewise the data is transmitted and received between the microcontroller and PC or other device vice versa.

Max232 pin diagram:

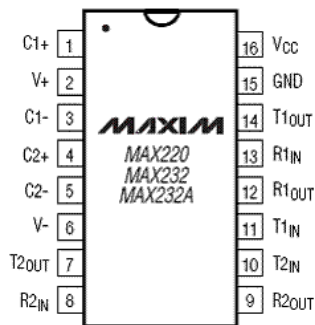

RF TRANSMITTER AND RF RECEIVER

General Description:

The 212 encoders are a series of CMOS LSIs for remote control system applications. They are capable of encoding information which consists of N address bits and 12-N data bits. Each address/data input can be set to one of the two logic states 0 or 1. The programmed addresses/data are transmitted together with the header bits via an RF medium.

Features:

- Operating voltage
 - _ 2.4V~5V for the HT12A
 - _ 2.4V~12V for the HT12E
- _ Low power and high noise immunity CMOS technology
- _ Low standby current: 0.1_A (typ.) at VDD=5V
- _ Four words for the HT12E
- _ One word for the HT12A
- _ Built-in oscillator needs only 5% resistor
- _ Data code has positive polarity
- _ Minimal external components
- _ HT12A/E:

18-pin Pin Configuration

ENCODER

The transmitter circuit is built using IC HT12E and TX 433.92Mhz module. The encoder HT12E has eight address and another four address/ data lines. The data set on this twelve-line (address and address/ data line) is serially transmitted when the transmit enable pin TE is taken low.

The data output appears serially on the D out pin. The data is transmitted in succession. It consists of different length of positive going pulses for "1"& "0". The frequency of these pulses between 1.5 and 7Khz depending on the resistor value between OSC 1 and OSC 2 pins. When transmit enable pin is pulled to ground potential, the selected address and data are available at D out, which is fed to data in of TX 433.92

DECODER

The complete RF receiver decoder circuit employing IC HT12D and RX 433.92 MHz, Holtec processor, which has eight-address line & four data line. When valuable data is received, one positive pulse is available at VT pin. This decoder IC receives the serially transmitted data, when address of transmitted data is matched with pre loaded decoder address. When it receives the valuable data, VT pin



gives acknowledge signal. The external resistor is connected across oscillator pin to generate base oscillation frequency up to 150Khz. The actual state of data pins are at low potential (low state). When it receives the valuable data, the corresponding data pin maintains the low potential and other pins go to high state.

PLUSE SENSOR

- The sensor consists of a light source and photo detector.
- Light is shown through the tissues and variation in blood volume alters the amount of light falling on the detector.
- The source and detector can be mounted side by side to look at changes in reflected light or on either side of a finger or earlobe to detect changes in transmitted light.
- The ends of each side of the peg are filed on the inside to enlarge the gap and pieces of black closed cell foam are stuck in place to improve grip and make a light tight seal against the skin.
- At this point, the spring should be adjusted so that the peg will grip an ear lobe while at the same time not being so tight that it excludes blood from a finger.

THERMISTOR

- ❖ A **thermistor** is a type of resistor used to measure temperature changes, relying on the change in its resistance with changing temperature.

- ❖ Thermistor is a combination of the words thermal and resistor.
- ❖ The LM35 consist of four independent, high gains, internally frequency compensated operational amplifier which were designed specifically to operate from a single power supply over a wide voltage range.
- ❖ The resistance decreases with increase in temperature.

DC MOTOR

A DC motor is a mechanically commutated electric motor powered from direct current (DC). DC motors can operate directly from rechargeable batteries, providing the motive power for the first electric vehicles. Today DC motors are still found in applications as small as toys and disk drives, or in large sizes to operate steel rolling mills and paper machines. A DC motor in simple words is a device that converts direct current (electrical energy) into mechanical energy. In order to understand the operating principle of dc motor we need to first look into its constructional feature.

- ❖ Speed 30 Rpm
- ❖ Current 3A
- ❖ Voltage 12v

OBJECT SENSOR

PIR / OBJECT SENSOR:



OBJECT SENSING CIRCUIT:

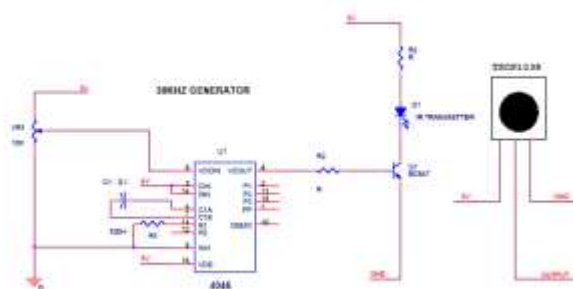

This project is used to sense the object for different application. The 4046 clock generator is used to generate 38 KHZ carrier signal which is transmitted through the sensor TSOP1038.

The CD4046 micro power phase locked loop consists of a low power, linear, voltage controlled oscillator, a source follower, a zener diode, and two phase comparators. The two phase comparators have a common signal input and a common comparator input. The signal input can be directly coupled for a large voltage signal, or capacitive coupled to the self biasing amplifier at the signal input for a small voltage signal.

TILT SENSOR

1. Switch Based Tilt Sensors: As the name suggests, these switch sensors answer the question whether the system is tilted or not. With just two states of outputs, switch based sensors are the most basic types. The sensors can be further classified into two types:

a. **Mercury Tilt Switch:** These switches employ a mercury bead which connects its terminals whenever it is tilted. Mercury tilt switches can be found in SPST and SPDT form depending upon the number of contacts used in them.

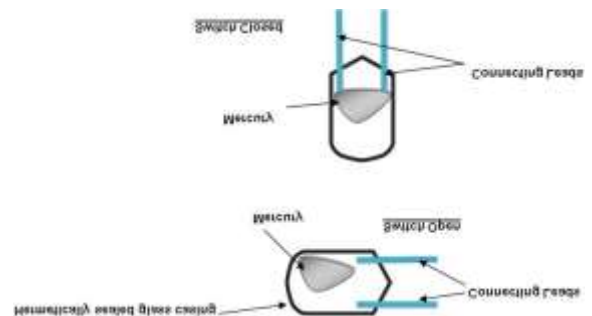

As seen from the images above, mercury, being a liquid metal can flow down and establish contact between the leads of the switch. The blob of mercury is able to provide resistance to vibrations as mercury is a dense liquid metal. Using mercury is discouraged as it is a toxic metal and poses a potential hazard to the user when the glass casing breaks and metal spillage take place.

Reed Switch

Working Principle

- ✓ When magnet come close to reed switch its start operating
- ✓ In this project work we are using four reed switches that are fixed in the mouth of user.



SOFTWARE DISCRIPTION

PROCEDURE TO BE FOLLOWED TO COMPILE THE PROGRAM USING FLOW CODE

1. Open C
2. Project → Project Wizard
3. Click Next
4. Choose Device (Pic 16f877a)
5. Choose The Compiler (Active Toolsuite : Hitech Picc Toolsuite (That We Have Used))
6. Create new project file

Project folder : C:\Documents and settings\Everwin\Desktop\ Can_temp\can_temp (your choice)

7. Click next (simply)
8. Click FINISH
9. FILE → NEW

Copy the main C coding (it is in the .zip file attached and with the name can_temp.c)

and Save as .C file (inside C:\Documents and settings\Everwin\Desktop\ Can_temp\can_temp

10. In the .mcw Window (PROJECT_NAME.mcw), you can see SOURCE FILES.
11. Right click → Add files → (add your .c file)
12. Now, your folder contains only 4 files (.C file, .Project file, . Project workspace, .mcs file)
13. Copy and paste delay.c, adc.c, lcd.c and lcd.h, can_config.h, and delay.h files.

Project → Build

Build successful

Now, your folder will contain .obj files and .hex files

Now your program is ready to get burnt in PIC.

Fix your PIC IC in the slot. Use the software (TOPWIN) to burn using program burner kit.

Click the icon (TOPWIN)

Choose the IC

File → Open (Choose the .hex file, that had created during compilation)

Choose address "00" and click OK

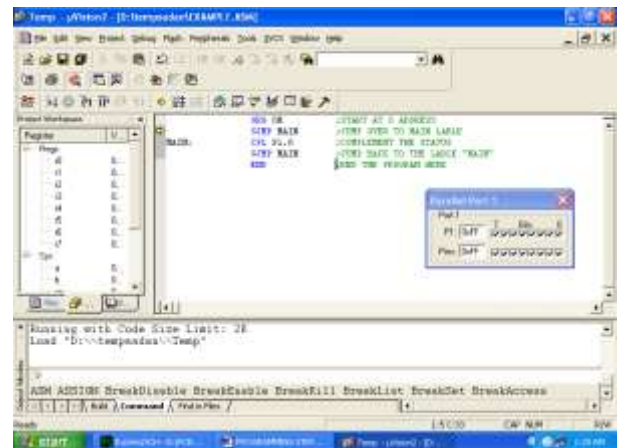

3. CONCLUSION

As the magnetic sensor based automated system has been presented which would be very helpful for physically challenged persons. If the controller identify any abnormality health condition of the user then it automatically sends SMS to the pre defined number stored in it with the help of GSM technology and it stops the vehicle. PIC C compiler is used to program for analog to digital conversion in PIC.

REFERENCES

- [1] M. Prathyusha, K. S. Roy , Mahaboob Ali Shaik, "Voice and Touch Screen Based Direction.and Speed

Control of Wheel Chair for Physically Challenged Using Arduino”, International Journal of Engineering Trends and Technology, vol. 4, issue 4, pp. 1242-1244, April 2014.

[2] Sangmeshwar S. Kendre et. Al, “Voice activated Multiprocessor embedded System to improve the control of a motorized wheelchair”, International Journal of Engineering Science and Technology, vol 2(11), pp 6812-6818, 2013.

[3] K. Sudheer, et al, “Voice and Gesture Based Electric-Powered Wheelchair Using ARM”, International Journal of Research in Computer and Communication technology, , vol 1, issue 6,pp 278- 283, November 2012.

[4] B. Blankertz et al., "The BCI competition 2003: progress and E.R.perspective in detection and discrimination of EEG single trials"IEEE Trans. Biomed Eng., vol. 51, pp. 100-106, 2014.

[5] N. Birbaumer et al., "The Thought Translation Device (TTD) for Completely Paralyzed Patients", IEEE Trans. Rehab. Eng., Vol. 8 (2), pp. 190 - 193, June 2013.

[6] M. Betke, J. Gips, and P. Fleming, "The Camera Mouse: visual tracking of body features to provide computer access for people with severe disabilities", IEEE Trans. Neural Sys.and Rehab, vol. 10, no. 1, pp. 1-10, March 2013.