

A Review Paper On

DEVELOPMENT OF GENERAL PURPOSE CONTROLLER BOARD

Ms. Aditi Girish Vaidya¹, Mr. Lakshman Korra²

¹M-Tech in Electronics Design and Technology, National Institute of Electronics & Information Technology Aurangabad, Maharashtra, India.

²Scientist 'D', National Institute of Electronics & Information Technology Aurangabad, Maharashtra, India.

Abstract - This paper exemplifies the design and development of a controller board with various peripherals for a different set of applications. It is portable system which can be used for controlling, displaying and manipulating the input. A general purpose controller board is basically a controller board which enables its use in distinct applications, which ultimately point out to its compatibility with other devices. The availability of various peripherals reduces the complexity of the product and minimizes the cost. Adding to this a temperature sensor is used to measure the temperature abode and then quantity is measured and displayed. This is a real time monitoring system. This controller board is designed in order to allow the micro-controller and devices to communicate with each other through a serial communication. It is an electronic platform based on easy to use hardware and software. The task can be performed by running a set of instruction which is programmed in a micro-controller.

Key Words: Controller Board, Microcontroller, Analog Sensing, Communication, Display, Sensor.

1. INTRODUCTION

The conventional integrated design environments for Microcontroller, FPGA or DSP boards are comparatively complex and requires the considerable time for learning. Also, the scientific research in the field of digital and analogue controlling applications has touched appreciable heights so that the initial research has sizable complexity from both practical and theoretical aspect. The controller comes up having all necessary set of peripheral drivers guaranteeing long term hardware and software compatibility. The availability of efficient drivers for the considered hardware platforms frees the users from the burden of low levelled programming. At the same time, the high-level programming approach facilitates software re-utilization, allowing the laboratory know-how to steadily grow along time. Lastly when both are integrated properly, a well-built setup for Real time (RT) simulations for oriented application can be carried out.

This will allow the developer to proceed with the implementation of the controller. In this the section II elaborates the proposed block diagram, section III includes the survey, comparison, selection of the components, section IV consists the designing blocks for each peripheral and respective schematic, section V consists of generation of gerber files for layouting, section VI includes Hardware Implementation and section VII determines the software implementation, testing and development details. As a result, the development of non-trivial applications, for demonstration as well as for scientific research purposes requires considerable efforts and relatively long times. All that, often, discourages students and prevents them from engaging the challenge altogether. The interest on digital computation platforms for the development of controllers and real-time simulation systems has increased significantly in recent years. This is also due to the needs, posed by smart grid applications, for the simulation of complex power system. This section aims to discuss in greater depth the various Hardware features of the controller. Each component is described in terms of its function and capabilities.

2. HARDWARE TOOLSET

2.1 PIC Controller

[1] The controller is controlled by dsPIC3EP device, configured as an I2C bus slave. The programming of PIC is done using MPLAB software released by Microchip Technology Incorporated. The dspic family has many features which are intended to maximize application such as flexibility and reliability and also the cost using different external components. The features include watchdog timer, flexible configuration, code guard and code protection, JTAG boundary scan programming, also Incircuit Serial Programming (ICSP) and brown out reset (BOR). The remappable inputs function are mapped at the same time and to the same pin. If any function has to be performed on pin that is enabled can be remapped.

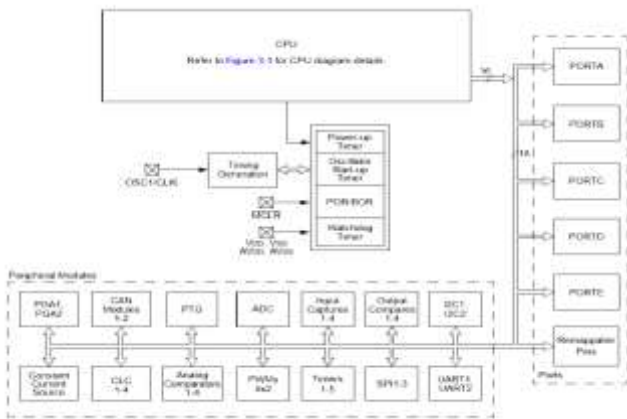

Fig -1: dsPIC33EPXXXGS70X/80X Family Block Diagram

2.2 Energy Metering IC

The ADE7754 is high accuracy electrical active power measurement ICs for three-phase applications with a pulse output. This intended output which is to be used for calibration purposes are considered. The ADE7754 consists of the ADCs, reference circuitry and all the signal processing which is required to perform active power and energy measurement. An ADE7754 provides Active Energy, RMS values, temperature measurement and Apparent Energy information via a serial interface.

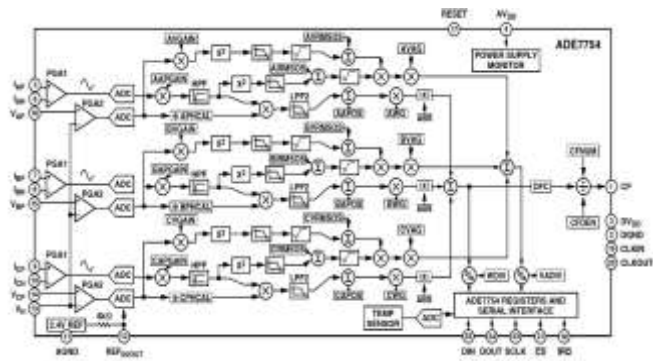

Fig -2: Functional Block Diagram

This paper describes the ADE7754 evaluation kit Hardware and Software functionality. This application note also describes how the current transducers should be connected for the best performance. Two external 5V power supplies and the appropriate current transducers are required.

2.3 Using CT as Current Transducer

The current at secondary is converted into voltage by using a burden resistance across the secondary winding outputs. Proper care should be taken when using a Current transformer as the current transducer. If no burden register is connected, a large voltage will appear at secondary outputs. This would result in causing shock hazard and

damaging electronic component. A maximum analog input range on the Current channel is set to 0.5V. The Gain of ADE7754 for Current channel should be set to 1.

3. ANALOG INPUTS

All analog input signals are filtered using the on-board anti-alias filters before being presented to the analog input of ADE7754. The user can easily make changes according to these components; however, this is not recommended unless the user is familiar with sigma-delta converters and also the criteria used for selection of the component values for the analog input filters.

3.1 Current Sense Input

As demonstrated below, connectors allow ADE7754's current inputs of phase A, B and C respectively to be connected to current transducers. The shunt resistors intended to use as burden resistors when CT's are used as the current transducers. The RC networks are used provide phase compensation when a Current Transformer is being used as the current transducer with the ADE7754. They are anti-alias filters which are required by the on-chip ADC's. The default corner frequency for these LPF's is selected as 4.8Khz.

3.2 Voltage Sense Input

The voltage inputs connections can be directly connected to the line voltage sources. The attenuation of line voltages is done using a simple resistor divider network before it is presented to the ADE7754. The attenuation network on the voltage channels has the corner frequency of the network matches that of the RC (anti-aliasing) filters on the available current channel inputs [5]. This is important, because if they do not match there will be large errors at lower power factors. The modification of attenuation network can be easily carried out by the user to accommodate any input signal level. However, the value of resistors with value 1K should not be altered as the phase response of voltage channels should not match the current channels. The maximum signal level endurable at VAP, VBP and VCP is 0.5 V peak for the ADE7754. ADE7754 analog inputs that can withstand $\pm 6V$ without damage, but the signal range should not exceed $\pm 0.5 V$ with respect to AGND. VN, analog input is connected to AGND via the anti-alias filter.

4. CALCULATIONS

4.1 Voltage Sensing

The fig above determines that the phase voltage sensed at the input is 230V AC. It is essential to obtain the differential voltage at the output. The differential output is about 0.5 V. For the purpose its necessary to place a 1M resistor. These voltages are with respect to the neutral.

$$V_R = 230 V$$

$$V_Y = 230 V$$

$$V_B = 230 V$$

Here placing a single can cause a problem to entire circuitry in case of high voltage input, palcing multiple resistors in series can help in such situation. SMD resistors 1206 are used with value of 333K each. Using voltage divider formula.

$$VAP = [R2 / (R1+R2)] X VIN \quad \dots (1)$$

$$VAP = [1K / (1K+(333K X 3))] X 230$$

$$VAP = 0.23V$$

$$VAP = 200-300mV$$

4.2 Current Sensing

In Fig.3. The current transformers are used for stepping down the current. TALEMA Group's AC1005 is used for the purpose. The CT is best suited for sensing overload protection, ground fault detection, metering and analog to digital circuitories. It has 5A nominal primary current and the maximum of 60 Amp is specified. The CT has nominal turns ratio of 1000:1. The terminating resistor and the one turn primary are not altered.



Fig -3: Current Transformer

4.3 Temperature Sensing

The temperature is measured with IC LM35DT. The output of temperature sensor is connected to the ADC circuit for digitalizing. But the IC to which the output is given does not accepts the output in terms of negative value. Hence there is need of connecting a Level Shifter for sensing output. The level shifter circuit is developed using the Operational Amplifier IC LM321.

Check the temperature range (2°C - 150°C) of system where the IC is placed. In our case it is approx. 62°C.

$$Vout \text{ at } 150^{\circ}C = 1500mV = 1.5 V \approx 3.3 V$$

$$Vout \text{ at } 25^{\circ}C = 250mv$$

$$Vout \text{ at } -55^{\circ}C = (-550 mV) = -0.5V \approx 0V$$

5. RESULTS

The devices thus used are related to industrial application based on real time value taken from the IC ADE7754. Some instructions prefetch mechanism helps maintain throughput and provides predicatable execution. Most instructions execute in single cycle effective execution rate, with the exception of instructions. Based on V_{IH} and V_{IN} value the pin will act as source or sink for current with respect to the pin of controller.

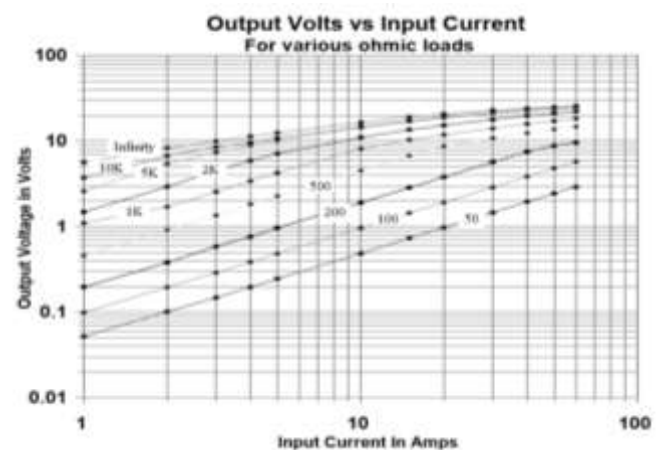

Fig -4: Voltage output Vs. Current Plot

Once the parameterization is done, it is put on manual mode to check every bank command is being transmitted to the switch. The permanent current monitoring inside the compensation system the measuring device should be able to determine the sum current of the complete system as well current of single branches.

6. CONCLUSION

The consequent development of the new innovative ideas and a multitude of functions. Several parameters that can be edited allow an optimized adjustment to the different modules. This module is distinguished by user friendly operation based on menu guided displays in plain text. Its features permit an intuitive mode of operation.

ACKNOWLEDGEMENT

I would like to express our profound sense of gratitude and appreciation to guide Mr. Lakshman Korra for his valuable guidance, continuous encouragement and help rendered in carrying out the work presented in this report. His constant

support has been the impetus for this work. It is his timely advice and friendly discussion, which has helped in framing this report. I am specially thankful to executive director Dr. Sanjeev Kumar Gupta for reviewing the manuscript and the valuable comments and suggestions he offered during the presentation of this report.

REFERENCES

- [1] dsPIC33EP128GS806 Digital Power PIM User's Guide.
- [2] Microchip Application Notes
- [3] Arjun Yadav and G. Narayanan : A Inexpensive Digital Controller for Power Electronic Applications.
- [4] Nick Davis: Safety Capacitors First- X capacitor and Y capacitors
- [5] https://nptel.ac.in/courses/Webcourse-contents/IIT-ROORKEE/Analog%20circuits/lecturers/lecture_15/lecture_15_page2.html