

Voltage Drop Compensation in Distribution System using Cascaded H-Bridge Multilevel Inverter based Dynamic Voltage Restorer with Voltage Control Scheme

N. Vijayalakshmi

Lecturer, Department of Electrical and Electronics Engineering, Government Polytechnic College, A. Kokkulam, Chekkanurani, Madurai, Tamil Nadu, India, 625514.

Abstract - Compensation of voltage sag that occurs in distribution line; based on cascaded multilevel inverter (CMLI) in dynamic voltage restorer (DVR) is proposed in this paper. Voltage sag in transmission line is widely increasing due to the usage of sensitive load and critical loads in industries and domestic applications. Voltage disturbances such as voltage dip and voltage swell are compensated by proposed CMLI in DVR method. Conventional voltage compensation method has some drawbacks such as complex structure, high cost and difficult to control. Here, for the protection of sensitive loads and critical loads from the aforesaid voltage sag problems are reduce by cascaded multilevel inverter in DVR and it is presented in this paper. It is mostly preferred to tackle with voltage interruption related PQ issues irrespective of load current profile. This paper analysis with design of DVR without transformer-based output voltage control with DC-AC converter using Clark's and Park's transformation based pulse width modulation control. This paper deals with the cascaded multilevel inverter in DVR, and it is analyzed for improvement of system stability. Clarke's and park's transformation technique based DVR is implemented and designed to evaluate the system performance and mitigation of voltage fluctuations using MATLAB/Simulink.

Key Words: Voltage sag, dynamic voltage restorer (DVR), cascaded multilevel inverter (CMLI), Clarke's and Park's transformation technique.

1. INTRODUCTION

In recent days there is a power quality demand in the distribution system due to increasing voltage sag and swell in non-linear or critical load in industrial applications. The problems mentioned above can be reduced either by compensating the voltage or current in the transmission line which improves the power quality of distribution station. Power quality enhancement in the distribution side has much achieved by power electronics devices. Different types of power electronics devices are used to improve the voltage compensation and power quality such as Static Var Compensator (SVC), Static Synchronous Compensator (STATCOM), Thyristor Controlled Series Compensator (TCSC), Interline power Quality Conditioner or Improved Power Quality Conditioner (IPQC), Thyristor Protected Series Compensation (TPSC), Unified Power Flow Controller (UPFC), Unified Power Quality Conditioner (UPQC) [1-3], and Dynamic Voltage Restorer (DVR). STATCOM [4-5] is used in the voltage compensation method to reduce the range of the filter. SVC is required for reactive power and voltage control. TCSC is applied in the transmission line for control of oscillation and maintain the power flow. IPQC is used for improving the current balances in the transmission line [5-8]. The traditional voltage compensation devices and methods had some drawback like complex structure, oscillation control, current balancing, high cost and difficult to control and so on. Among these above mentioned traditional devices, DVR is the most emerging process, and it injects a voltage in series with the transmission line. It is series connected custom power devices which secure the loads from damage. It is mostly preferred to tackle with voltage interruption related PQ issues irrespective of current load profile. Traditional dynamic voltage restorer is used the voltage source inverter, input as DC source/battery connected with the transformer and generate the desired output voltage to compensate the drop and swell in the transmission line. As compared to other voltage compensation methods, it requires fewer components and also there is no need for a transformer. Capacitor in DVR which replenishing the energy so that there is no necessity of energy storage devices in DVR to restoring the energy. Voltage compensation capability of DVR depends on the capacity of energy storage system. DVR based cascaded multilevel inverter is presented in this paper for compensating both voltage sag. Reduction of voltage stress on switches, harmonics distortion and high output quality is achieved by the proposed inverter. The general view of the cascaded multilevel inverter is used to generate synthesized output waveforms from small step voltage with low harmonic distortion, high voltage. In this paper, cascaded multilevel inverter in DVR [9-11] is used for raise the voltage levels at small steps. One terminal of cascaded H-bridge is connected with sending end (source side), and another terminal of the bridge is connected with receiving end (load side) of the transmission line. Cascaded multilevel inverter switches can be controlled by various techniques such as hysteresis controller, pulse width modulation, predictive controller and sliding mode controller. Clarke's and Park's transformation method is used as feedback of pulse width modulation (PWM) technique. This control schemes [12-13] in DVR to control and maintain the output voltage at balanced condition even the fault periods. This paper

presents the transformerless series operation of the dynamic voltage restorer system for improvement of power quality. During the unbalanced power supply condition, harmonic reduction and voltage sag compensation are analysed. Improvement of this topology is obtained by a fuzzy based PV system with Clarke's and park's transformation technique [14]. This proposed controller is used to preserve the DC link voltage of cascaded multilevel inverter. Simulations results are made and voltage drop are validate by using MATLAB/Simulink tool. Single line diagram of the proposed DVR is shown in Fig -1.

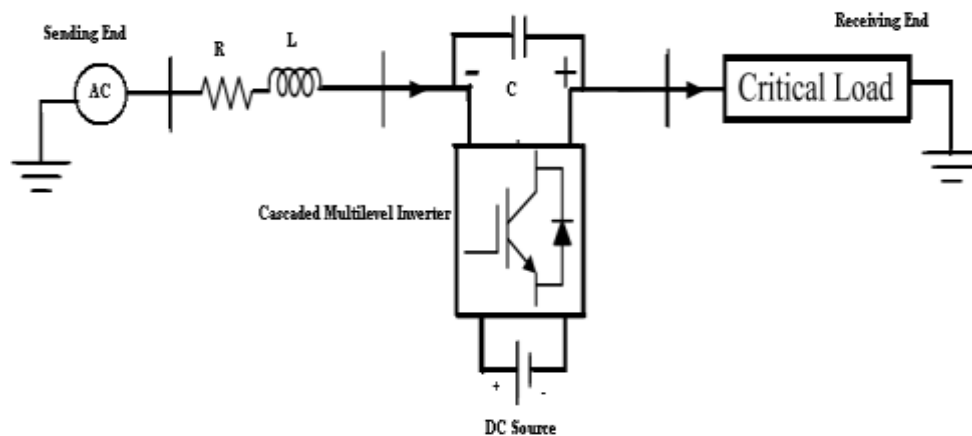

Fig -1: Single line architecture of dynamic voltage restorer

2. PROPOSED METHODOLOGY

Proposed system consists of a cascaded multilevel inverter in DVR for injecting voltage to the transmission line through the combination of filters (inductance, capacitance and resistance).

2.1 DVR System and Operation

The multilevel inverter in DVR system is shown in Fig -2. This proposed system helps to compensate the voltage sag in the transmission line. DVR is voltage source inverter which injects the compensated voltage is in series with the supply voltage of transmission line. An input of the inverter is takes from the PV panel. The function of the inverter is used to regulate the DC link voltage. In conventional, cascaded multilevel inverter with transformer was presented. Without transformer in transmission line based cascaded multilevel inverter DVR is implemented in this paper.

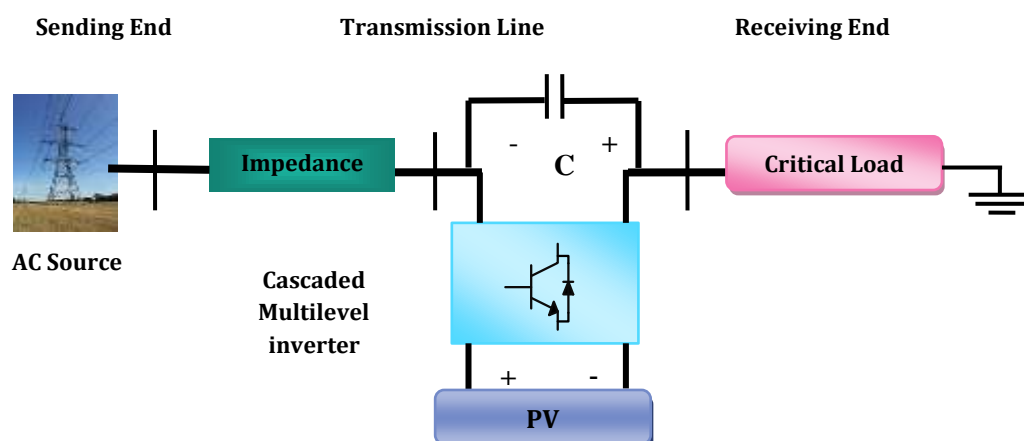

Fig -2: Block diagram of cascaded H-bridge based DVR

The sending end voltage (V_g) changes its value then the voltage is injected by the DVR (V_d) to maintain the load voltage amplitude. Based on this amplitude, voltage compensation is possible in three methods there are pre-fault, post-fault, and zero

faults. Injection of voltage is in phase with source (Grid), and the load voltage kept at constant is represents the post-fault. Injected voltage is greater than or equal to the supply voltage represents the pre-fault. Phasor diagram of this fault method is represented in Fig -3. In general, DVR injects the voltage of real and reactive power. In reactive power, there is no energy from the dc link capacitor and active power is energy transfer. Once the DVR replenished the energy means, which is capable to mitigate the voltage drop with long period in the transmission line. Voltage sag compensation is corrected by series injection of voltage is represents in equation

$$V_D \angle \alpha = V_L \angle 0 - V_G \angle -\delta \tag{1}$$

- α - Injected angle of DVR
- δ - Voltage angle of Grid side
- V_L - Load voltage
- V_G - Grid voltage
- V_D - DVR voltage

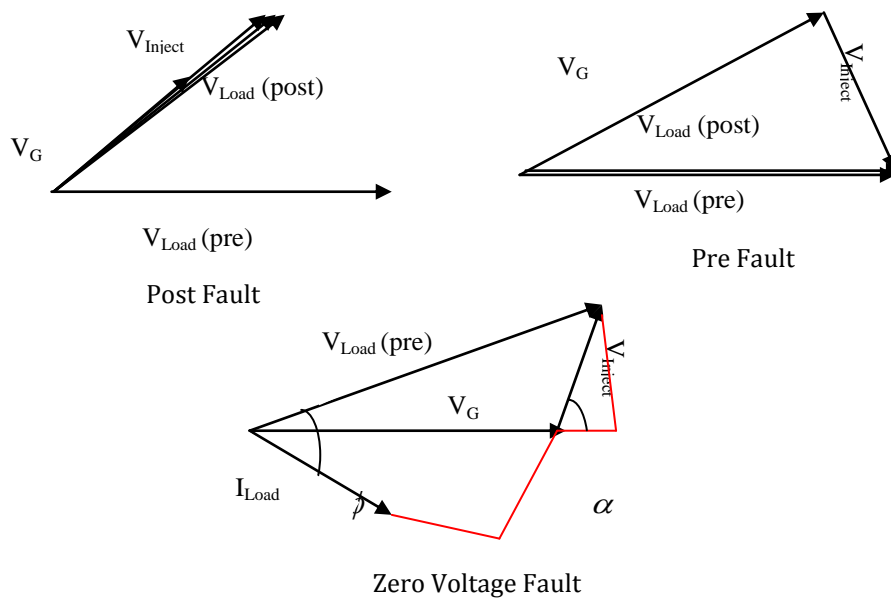

Fig -3: Phasor diagram of different fault methods

2.2 Cascaded Multilevel Inverter

Proposed cascaded H-bridge inverter topology is shown in Fig -4 and it is suitable for high power application because of its modular structure. This topology eliminates the requirements of the transformer which saves the overall cost and reduces the circuit complexity. In conventional, the 5-level cascaded multilevel inverter was proposed. This paper proposes with less switch count of cascaded multilevel inverter to compensating the voltage sag, harmonics reduction, and also reduces the unwanted electromagnetic interference during the fault. During short circuit fault, load current in the transmission line increases linearly. At that time, switches in DVR system are turns ON for injecting the voltage to distribution line through the filters.

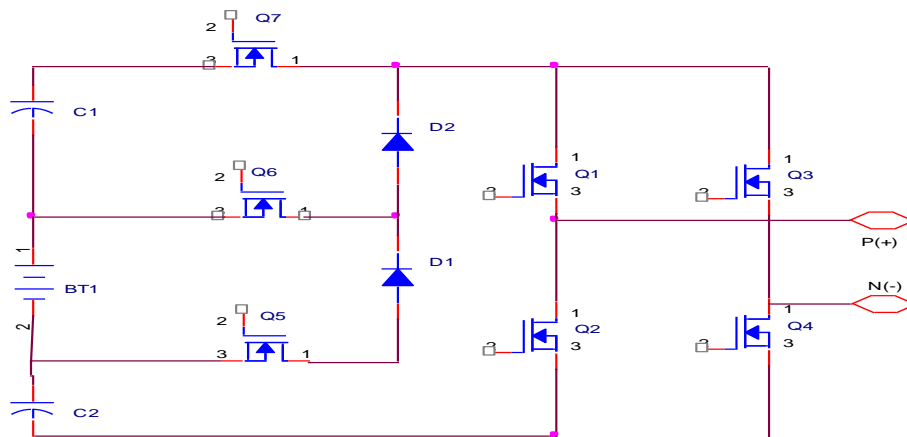

Fig -4: Cascaded H bridge inverter cell for single phase

3. CONTROL OF CASCADED MULTILEVEL INVERTER USING CLARKE'S AND PARK'S TECHNIQUE WITH PWM METHOD

The different type of control methods are used to control inverter. The combined topology of Clarke's and Park's transformation based DVR control is proposed in this paper. Control scheme of cascaded multilevel inverter in DVR system is shown in Fig -5. Working of control topology is to sense the voltage reduction, and injects the required range of voltage to the transmission line. When the voltage exceeds their threshold voltage, the grid voltage is considered as sag. Sag can be calculated by comparing the dq components of injecting voltage to the dq components of supply voltage. During the sag mode, dc link voltage regulates the capacitor charges at rated voltage. In this way, the DC link was controlled by using this control scheme.

$$\left| \begin{matrix} - \\ U_{sag} \\ - \end{matrix} \right| > U_{threshold} \tag{2}$$

By Clark transformation and park's transformation technique grid voltage (V_G) is converted into V_d and V_q , and V_G is converted into d,q that is given in the below equation in 3&4 Then the generated d,q values are compared with a reference voltage and produce an error signal. An error signal is converted into the voltage signal to pulse generation signal. Generated output of this method is used for pulse generation process of the multicarrier pulse width modulation and it is represented in Fig -6.

$$\begin{pmatrix} V_d \\ V_q \end{pmatrix} = \sqrt{2} * \begin{pmatrix} \sin \omega t & -\cos \omega t \\ \cos \omega t & \sin \omega t \end{pmatrix} * \begin{pmatrix} 1 & -1 & -1 \\ 2 & \sqrt{3} & \sqrt{3} \\ 0 & 2 & 2 \end{pmatrix} * \begin{pmatrix} V_1 \\ V_2 \\ V_3 \end{pmatrix} \tag{3}$$

$$\begin{pmatrix} V_1 \\ V_2 \\ V_3 \end{pmatrix} = \sqrt{2} * \begin{pmatrix} 1 & 0 \\ -1 & \sqrt{3} \\ 2 & 2 \\ -1 & \sqrt{3} \\ 2 & 2 \end{pmatrix} * \begin{pmatrix} \sin \omega t & \cos \omega t \\ -\cos \omega t & \sin \omega t \end{pmatrix} * \begin{pmatrix} V_d \\ V_q \end{pmatrix} \tag{4}$$

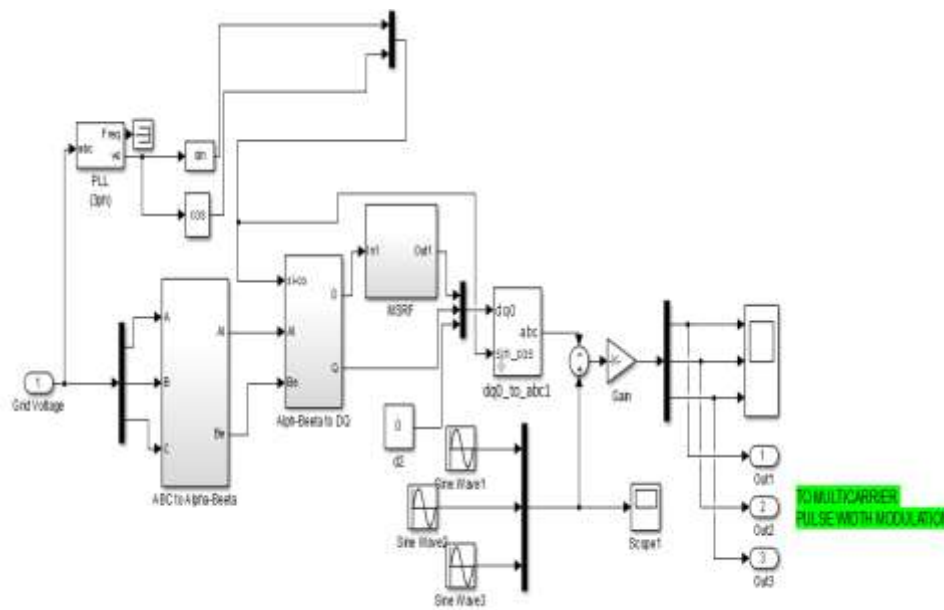

Fig -5: Control scheme of transformer-less DVR system

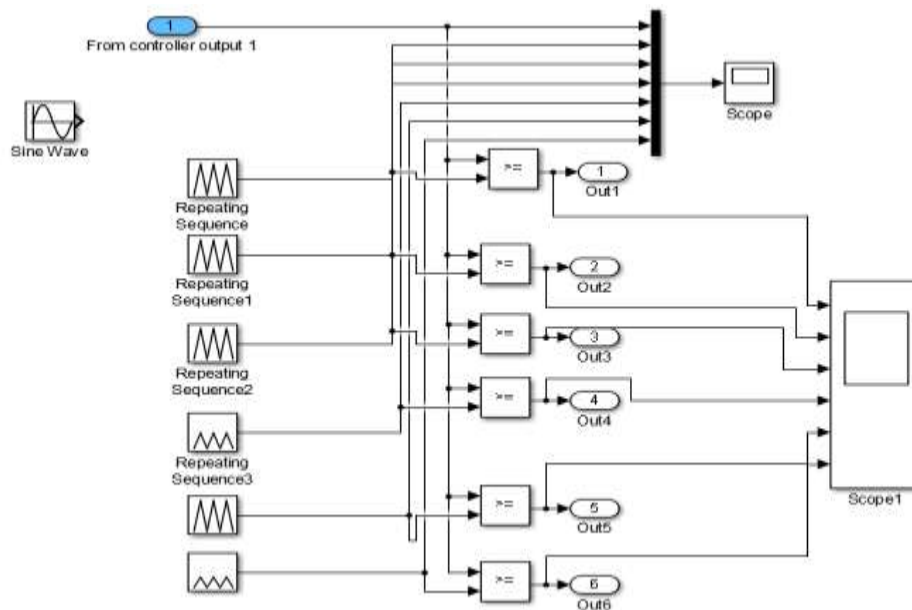

Fig -6: Multicarrier PWM based pulse generation

4. SIMULATION RESULTS

Design of transformerless DVR using Clark's and park's transformation with multicarrier PWM technique using MATLAB/Simulink. Pulse generation of inverter is obtained by designing of PWM. Critical and sensitive loads are connected at receiving terminal of the transmission line, and those loads are protected by DVR from severe damage without using transformer. The transformerless cascaded multilevel inverter in DVR system is represented in Fig -7. At the time of 0.45sec - 0.6sec, external fault is occurred between the source and load. Fig -8 and Fig -9 represents the grid voltage (V_g) and current (I_g). Fig -10 represents the nominal grid voltage sag, injected voltage and compensated voltage. This voltage drop can be compensated by using the CMLI in DVR system. It injects the voltage upto 450v. THD value of output current (7.54%) is shown in Fig -11.

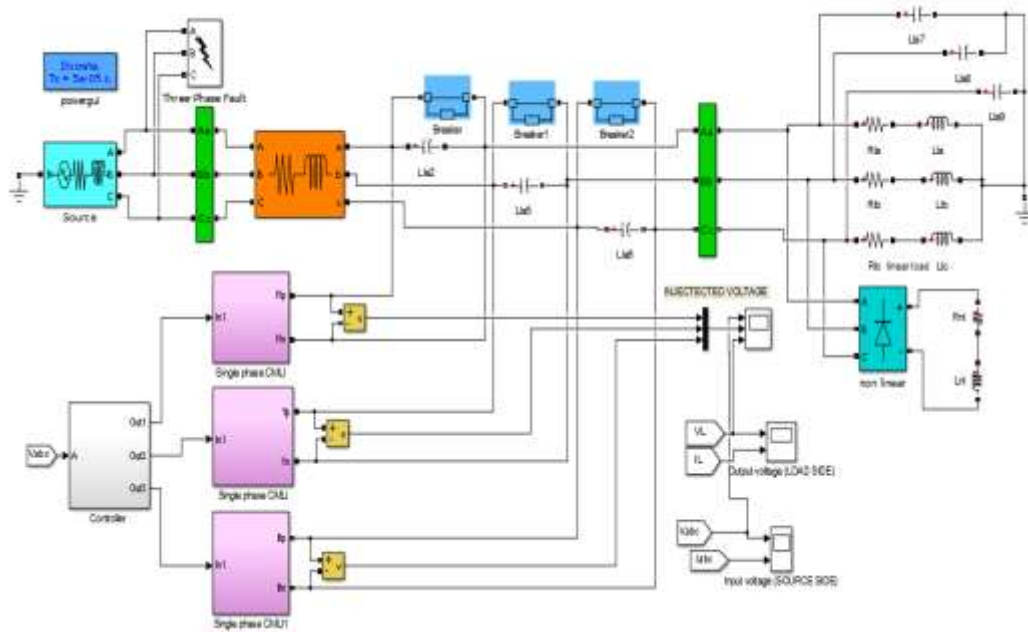

Fig -7: Simulation diagram of cascaded H-bridge inverter based DVR system

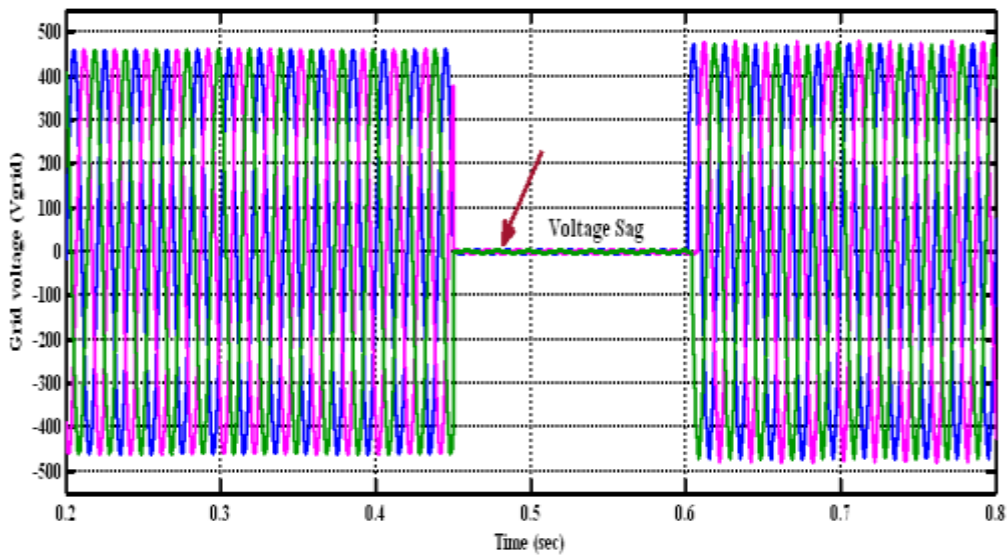

Fig -8: Grid voltages (Vgrid)

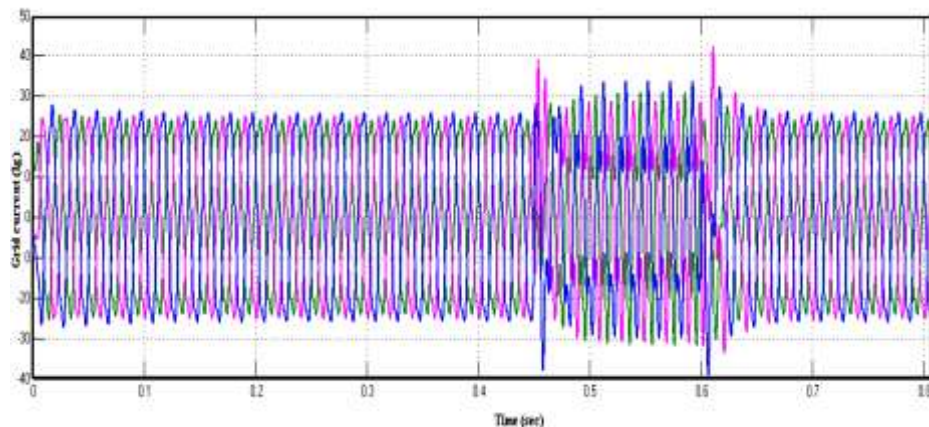

Fig -9: Grid current (Igrid)

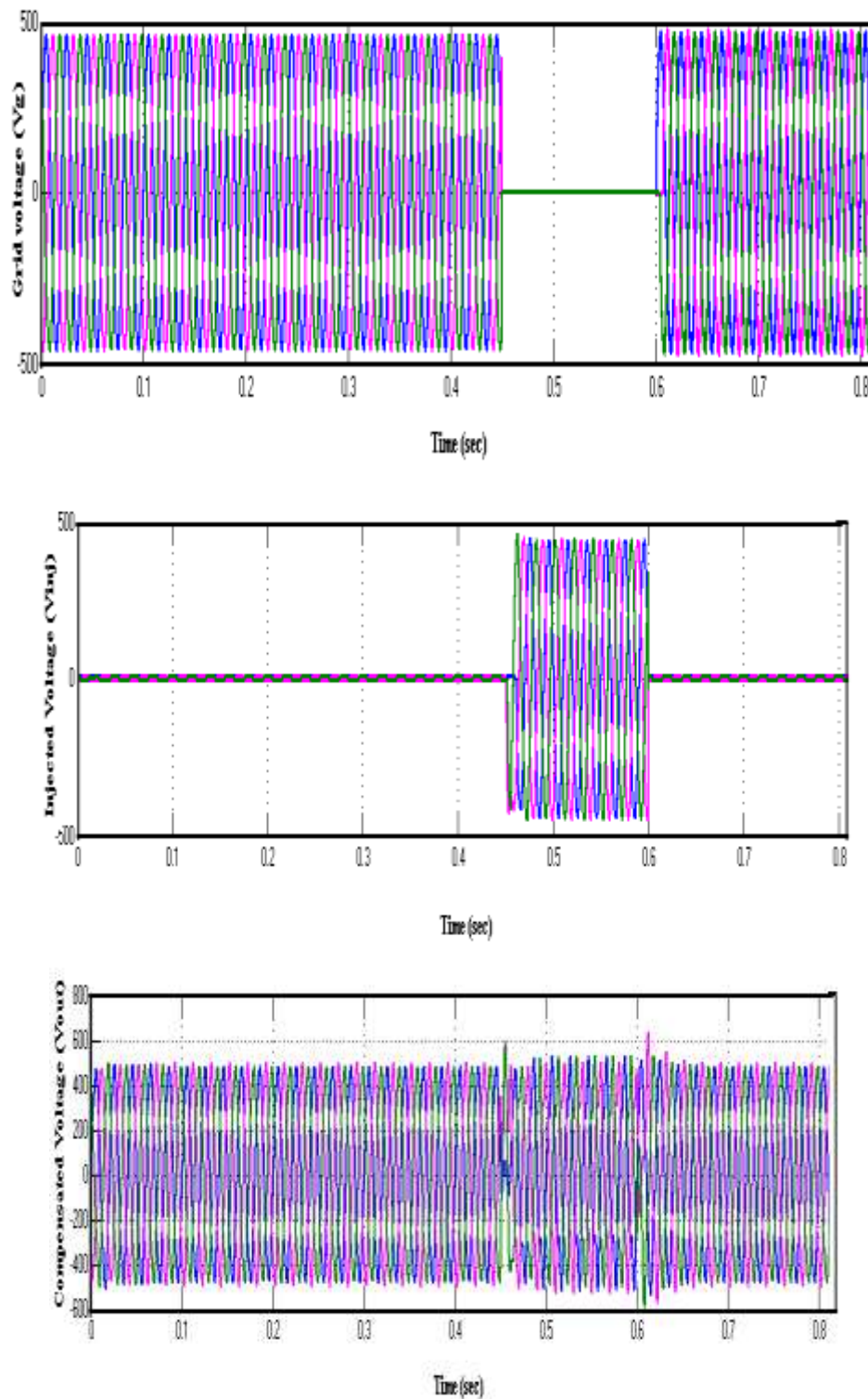

Fig -10: Waveform of voltage sag, injected voltage, compensated voltage

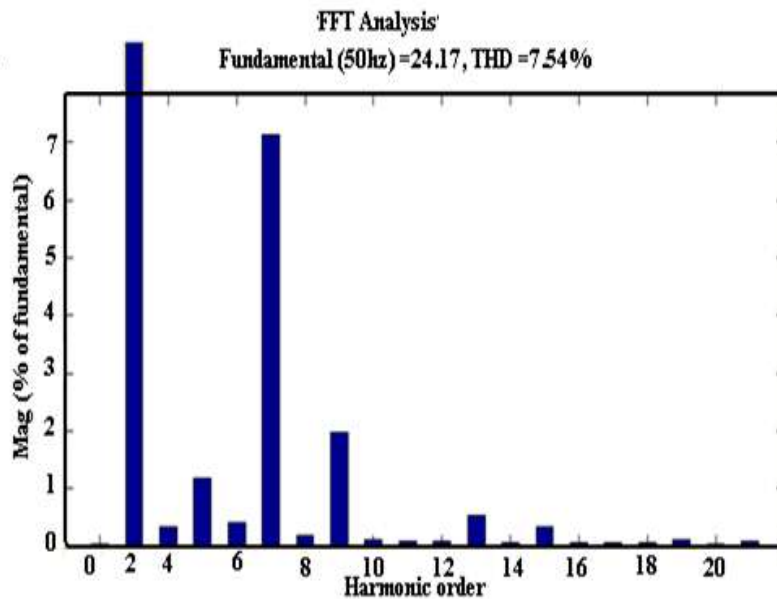

Fig -11: THD value of the output current

5. CONCLUSION

Transformerless cascaded multilevel inverter is designed by the combination of Clarke's and Park's transformation technique for controlling the inverter switches in DVR and it is implemented in this paper. The proposed control topology improves the stability across the load voltage and minimizes the voltage sag. Cascaded multilevel inverter in power system have advantages such as reduces the switches count, increases the voltage gain, increases an effectiveness of the system, and reduced the overall cost. Cascaded multilevel inverter reduces the harmonics (%THD=7.54). Voltage compensation and increasing voltage stability of the load is achieved by the series connection of DVR and their performance is verified by MATLAB/Simulink.

REFERENCES

- [1] S.K. Dash and P.K. Ray, "Power quality improvement utilizing PV fed unified power quality conditioner based on UV-PI and PR-R controller," CPSS Transactions on Power Electronics and Applications, vol.3, no. 3, 2018, pp.243-253, doi: 10.24295/CPSSPEA.2018.00024.
- [2] A.M. Rauf, A.V. Sant, V. Khadkikar and H.H. Zeineldin, "A novel ten-switch topology for unified power quality conditioner," IEEE Transactions on power electronics, vol. 31, no. 10, 2016, pp.6937-6946, doi: 10.1109/TPEL.2015.2509510.
- [3] Q.N. Trinh and H.H. Lee, "Improvement of unified power quality conditioner performance with enhanced resonant control strategy," IET Generation, Transmission & Distribution, vol. 8, no. 12, 2014, pp.2114-2123, doi: 10.1049/iet-gtd.2013.0636
- [4] L. Feola, R. Langella, I. Papič and A. Testa, "Selective Inter harmonic Compensation to Improve Statcom Performance for Light Flicker Mitigation," IEEE Transactions on Power Delivery, vol. 33, no. 5, 2018 pp.2442-2451, doi: 10.1109/TPWRD.2018.2810333.
- [5] S. Mishra and P.K. Ray, "Power quality improvement using photovoltaic fed DSTATCOM based on JAYA optimization," IEEE Transactions on Sustainable Energy, vol. 7, no. 4, 2016, pp.1672-1680, doi: 10.1109/TSTE.2016.2570256.
- [6] T.S. Saggi, L. Singh and B. Gill, "Harmonics Mitigation in a Steel Industry Using 11-Level Cascaded Multilevel Inverter-Based DSTATCOM," Canadian Journal of Electrical and Computer Engineering, vol. 40, no. 2, 2017, pp.110-115, doi: 10.1109/CJECE.2017.2681686.
- [7] H. Myneni, G.S. Kumar and D. Sreenivasarao, "Dynamic dc voltage regulation of split-capacitor DSTATCOM for power quality improvement," IET Generation, Transmission & Distribution, vol.11, no. 17, 2017, pp.4373-4383, doi: 10.1049/iet-gtd.2017.0494.

- [8] M. Kumar, A. Swarnkar, N. Gupta and K.R. Niazi, "Design and operation of DSTATCOM for power quality improvement in distribution systems," *The Journal of Engineering*, vol. 2017, no. (13), 2017, pp.2328-2333, doi: 10.1049/joe.2017.0747
- [9] M. Zhou, Y. Sun, M. Su, X. Li, J. Lin, J. Liang and Y. Liu, "Transformer-less dynamic voltage restorer based on a three-leg ac/ac converter," *IET Power Electronics*, vol. 11, no.13, 2018, pp.2045-2052, doi: 10.1049/iet-pel.2018.5396.
- [10] D.A. Fernandes, F.F. Costa, J.R. Martins, A.S. Lock, E.R. da Silva and M.A. Vitorino, "Sensitive load voltage compensation Performed by a Suitable Control Method," *IEEE Transactions on Industry Applications*, vol. 53, no. 5, 2017, pp.4877-4885, doi: 10.1109/TIA.2017.2715173.
- [11] C. Kumar and M.K. Mishra, "Predictive voltage control of transformerless dynamic voltage restorer," *IEEE Transactions on Industrial Electronics*, vol. 62, no. 5, 2015, pp.2693-2697, doi: 10.1109/TIE.2014.2365753.
- [12] A.M. Rauf and V. Khadkikar, "An enhanced voltage sag compensation scheme for dynamic voltage restorer," *IEEE Transactions on Industrial Electronics*, vol. 62, no. 5, pp.2683-2692, doi: 10.1109/TIE.2014.2362096.
- [13] A.P. Torres, P. Roncero-Sanchez and V.F. Batlle, "A two degrees of freedom resonant control scheme for voltage-sag compensation in dynamic voltage restorers," *IEEE Transactions on Power Electronics*, vol. 33, no. 6, 2018, pp.4852-4867, doi: 10.1109/TPEL.2017.2727488.
- [14] P. Jayaprakash, B. Singh, D.P. Kothari, A. Chandra and K. Al-Haddad, "Control of reduced-rating dynamic voltage restorer with a battery energy storage system," *IEEE transactions on industry applications*, vol. 50, no. 2, 2014, pp.1295-1303, doi: 10.1109/TIA.2013.2272669.