

“CONCEPT VALIDATION AND DESIGN SYNTHESIS OF CAR DASHBOARD AS PER PLASTIC TRIM STANDARD”

Jayesh Sudhakar Sarode¹, Vijay Liladhar Firake², Dr. Atul Patil³

¹*MTech -Scholar, Department of Mechanical Engineering JTMCOE, Faizpur.*

²*Assistant Professor, Department of Mechanical Engineering, JTMCOE, Faizpur*

³*Managing Director, IKSC Knowledge Bridge Pvt. Ltd. Pune*

Abstract - *The evolution of dashboard has led to increased vehicle occupant comfort and convenience as new systems become available. The project work aims to develop the work to apply theoretical and practical tools/techniques to solve real life problems related to industry and current research in this project automobile (Car) dashboard upper cover is selected for a design. For doing so conceptual design tool is used. I am created a five different concepts using different benchmarking & brainstorming. Select a best option using different tools in six sigma like trade off analysis. Three-dimensional CAD software (such as CATIA) is used to develop a CAD model same as concept. The aim is to achieve the essential function at the lowest overall cost while maintaining customers’ optimum value assurance. In this project I try to develop a such dashboard design which follow a design guidelines, And analyze and discuss the results to Obtain valid conclusions which follows a design Standards.*

Key Words: Conceptual design, Car Dashboard design, concept validation, Plastic Trim Design....

1. INTRODUCTION

Automotive dashboard is one of the most important parts in vehicle interior parts. Automotive manufacturer need to consider the quality, cost, reliable design and safety of the product when study the conceptual design of automotive parts. Ergonomics design criteria is considered during design process. In the context of the dashboard, ergonomic design will ensure the display in the instrument cluster can be easily seen and the vehicle control system can be easily reached by the driver. Plastic part dashboard is designed by following Plastic trim design guidelines as well as DFM (Design for manufacturing) and DFA (Design for Assembly) guidelines.

Designing plastic parts and components involve implementing wide knowledge from different engineering areas. A successful design process requires a coherent teamwork between a designer and other specialist such as a tool designer and a manufacturing operator. Regardless, a part design often passes sequentially from concept development to the manufacturing phase with features that unnecessarily complicate production and add costs. It can result to a decreased product performance and a premature failure. For a plastic part to maintain quality of part many

factors are consider like design, tooling, processing, handling and assembling, part estimate life, etc.

Table -1: Requirements relative to a corresponding life cycle stage.

Life cycle stage	Requirements
Design	Specified and understood part behavior under anticipated service conditions Consideration for the whole life cycle Agency approvals
Tooling	Proper documentation Integrated tooling principles Adjustment allowance
Manufacturing	Effective cycle-time Proper mold filling Material availability
Assembly and handling	Error-free assembly, Practical handling
Service	A product that functions as intended; Sufficient strength Impact resistance Stiffness Friction Dimensional accuracy Surface quality
End of Life	Minimal environmental impact

Table -2. influences relative to a corresponding life cycle stage.

Life cycle stage	Influences
Design	Part geometry Material selection Manufacturing Short-term mechanical stresses Long-term mechanical stresses Thermal stresses Environmental stresses
Tooling	Part geometry Material selection Production volume
Manufacturing	Part geometry Material selection
Assembly and handling	Part geometry Material selection
Service	Part geometry Material selection Manufacturing Short-term mechanical stresses Long-term mechanical stresses Thermal stresses Environmental stresses
End of Life	Part geometry Material selection

2. METHODOLOGY

The standardized process used. The idea of dashboard design can be illustrated in a few conceptual designs. To choose final design, the best design selected using the concept score used. The CAD modeling of final design was performed by using CATIA P3 V5- 6R2017 software. To generate conceptual designs firstly collect a data who is customer and what is a need of customer? Called voice of customer, using market survey collect this data and take it as a input to design a new product or upgrade a product by using engineering tolls and knowledge.

Table -3 Voice of Customer

VOC (VOICE OF CUSTOMER)	Engineering Comments
Low Space Utilization	Reliable design/ flexible design
Reliable design/ flexible design	Good ergonomics
Structure / geometry / mechanism / Attractive Design	Plastic Trim
Controls & Electronic functions should be convenient to use	Distance to access the controls
Good ergonomics	Design not be overdesigned
Less Weight	Choose of Material
Durability	Rigid and strong material
Comfortable and convenient System	Good ergonomics
while dashboard Design it must follow plastic Trim guidelines	Safer Design & Easy to Manufacture
Dash board noise and vibration should be less in the cabin	Packaging

causes of failures -

- 45% Design
- 20% Poor specification and material selection
- 20% Processing
- 15% Misuse

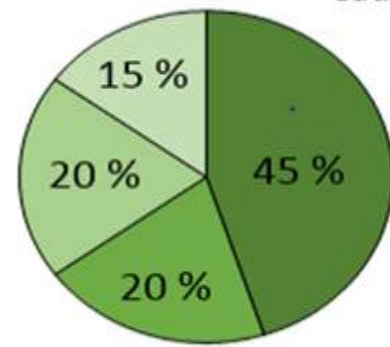

Fig -1: Distribution of causes of failures.

3. CONCEPT GENERATION

From the engineering comment we are generate a concept. The most suitable design was selected using concepts scoring. The maximum point was selected as the final design. Concepts are generated using various methods like benchmarking, brainstorming, Establishing the primary Concept, Developing Alternative to Primary Concept, Working through concept Contradiction etc

3.1 Benchmarking

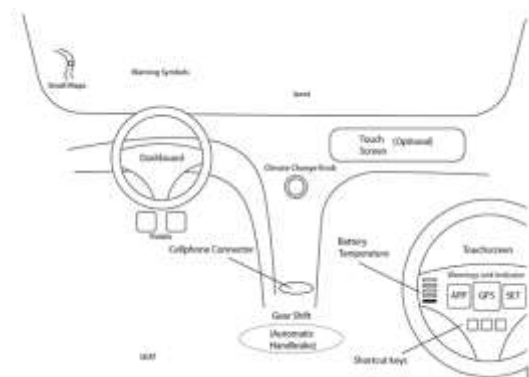

Fig -2: Concept 1

3.2 Brainstorming

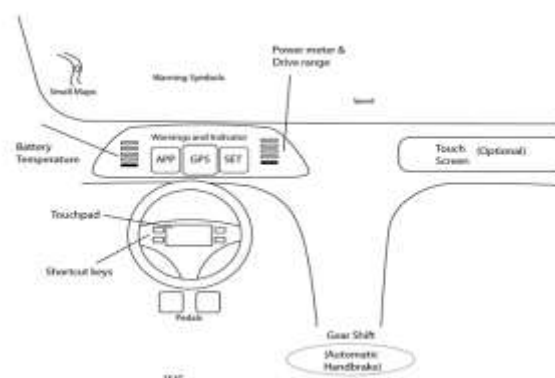

Fig -3: Concept 2

3.3 Establishing the primary Concept

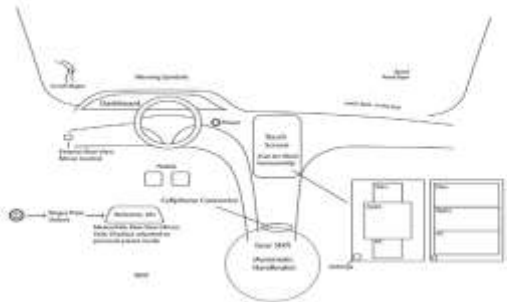

Fig -4 Concept 3

3.4 Developing Alternative to Primary Concept

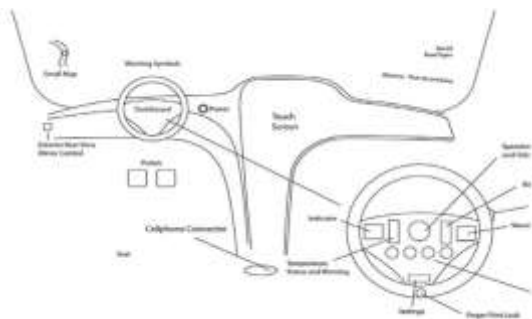

Fig -5 Concept 4

3.5- Working through concept Contradiction

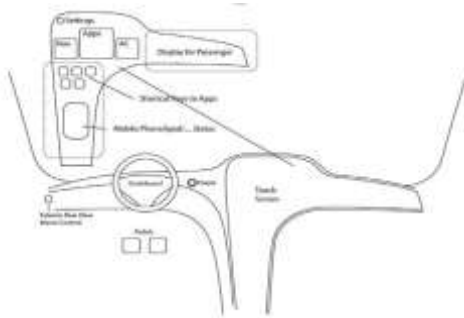

Fig -6 Concept 5

4. CONCEPT VALIDATION

The concept validation key criteria is figure out from voice of customer and automotive plastic trim standard. Like plastic part is designed for manufacturing in injection molding for that part should be clear in draft for part ejection and follow tangency all over the part to aesthetic surface.

It is a cyclic process that consists of sequential steps, which are simply stated the following:

- Melting of the plastic granules and conveying the melt towards the injection unit. A shot, predefined amount of melt is injected into the mold to produce the part.

- Injection of the plastic melt into the mold under a high pressure through the gate. Gate location has a great impact on mold filling and to the embodiment of a part. Design features such as wall thickness and ribs influence on the mold filling.

- Cooling and solidifying of the plastic in the mold, while a part is also shrinking. Differential shrinking causes visual defects.

- Ejection of the molded part from the mold by ejector pins or rings. A draft angle in the wall of a part facilitates ejection.

To Validate a concept In trade off analysis is done on design Alternatives are compared by following manner.

Table -4 Tradeoff Analysis

Pugh Matrix		Compare Alternatives					
Concept Selection Legend		Importance Rating	Alternative 1	Alternative 2	Alternative 3	Alternative 4	Alternative 5
Better	+						
Same	S						
Worse	-						
Key Criteria							
Product reliability	8	-	S	+	+	S	
Volume and Packaging	7	+	-	+	-	S	
Design for strength and stiffness	8	S	-	S	+	+	
Design According to DFM	9	-	+	+	S	-	
Design According to Aesthetic	7	S	S	+	-	+	
Design According to DFA	9	+	-	+	S	-	
Design for Safety	10	+	+	S	+	S	
Less weight of Product	6	-	S	+	-	+	
Low Cost	7	-	S	+	S	-	
Light weight	8	S	-	+	-	+	
Easy to manufacture	9	+	S	+	+	S	
Design Based on Standards Of Plastic	10	-	-	S	+	S	
Process parameters	6	-	+	-	-	+	
Long Service Life of Product	5	S	-	S	S	-	
Less No Of Component	7	+	S	-	-	-	
Clear in Draft With MTD	10	-	+	+	+	S	
Sufficient area and volume for driver and Passenger	9	S	+	+	-	+	
product should match vehicle Appearance	8	-	-	+	S	-	
Follow A Surface Tangency	10	S	S	S	+	+	
ergonomics design	7	+	+	+	S	S	
design for aesthetics, color gradation, styling	8	-	-	+	-	S	
Reliable design/ flexible design	9	-	+	S	+	-	

Sum of Positives		6	7	14	8	7
Sum of Negatives		10	8	2	8	7
Sum of Same		6	7	6	6	8
Weighted Sum of Positives		49	60	112	81	63
Weighted Sum of Negatives		13	58	54	0	0
For Best Outcome Select Best Weighted Sum of Positive outcome				112		

So For Best Outcome Select Best Weighted Sum of Positive outcome which is **Alternative 3** is selected for further Study.

5. VISUALIZATION CONCEPT TO CAD

The visualization process is a process in which concept design sketches convert to CAD model. The visualization process contains three stages. The first stage is mainly developing a visual structure, creating wireframes and delivering a wide range of sketches, while in the next style development stage, the general look is created based on the first stage and the function hierarchy structure. In the last visualization stage the whole design is refined by looking into details in CAD model.

Following factors are consider in while considering concept to CAD

- Required strength (including impact and flexural strength)
- Specified range of service temperatures
- Exposure to chemicals and harsh environments
- Appearance requirements
- Dimensional tolerances
- Required agency approvals
- Processing method
- Assembly method

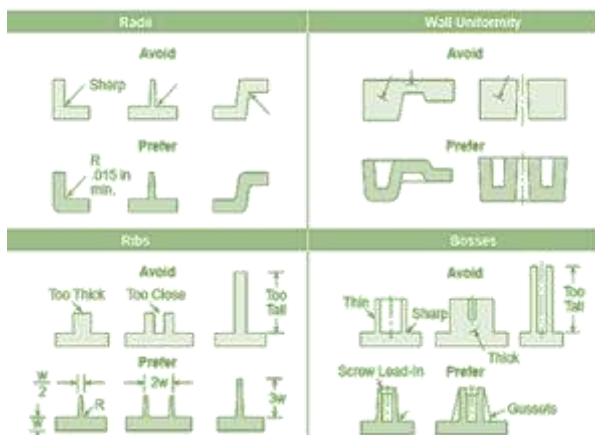

Fig -7 Design guidelines for plastics.

Injection Molding Design Guidelines-

Much has been written regarding design guidelines for injection molding. Yet, the design guidelines can be summed up in just a few design rules.

- Use uniform wall thicknesses throughout the part. This will minimize sinking, warping, residual stresses, and improve mold fill and cycle times.
- Use generous radius at all corners. The inside corner radius should be a minimum of one material thickness.
- Use the least thickness compliant with the process, material, or product design requirements. Using the least wall thickness for the process ensures rapid cooling, short cycle times, and minimum shot weight. All these result in the least possible part cost.
- Design parts to facilitate easy withdrawal from the mold by providing draft (taper) in the direction of mold opening or closing.
- Use ribs or gussets to improve part stiffness in bending. This avoids the use of thick section to achieve the same, thereby saving on part weight, material costs, and cycle time costs.



Fig -8 Life cycle of a plastic product.

6. RESULT

In this Project I am developing a CAD Model by conceptual design then convert it into wireframes and surfaces using tool CATIA V5.as shown in fig 9.

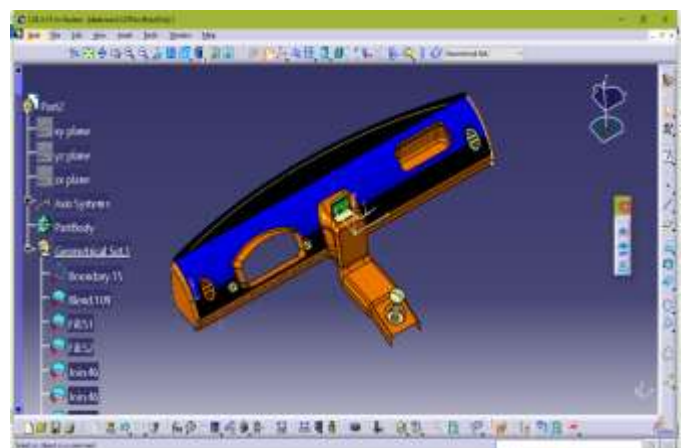

Fig -9 Concept 3 Visualization Model

Fig 9 model is modified according to plastic guidelines as disused above and it is successfully modified to clear in draft angle with 0.48 degree.

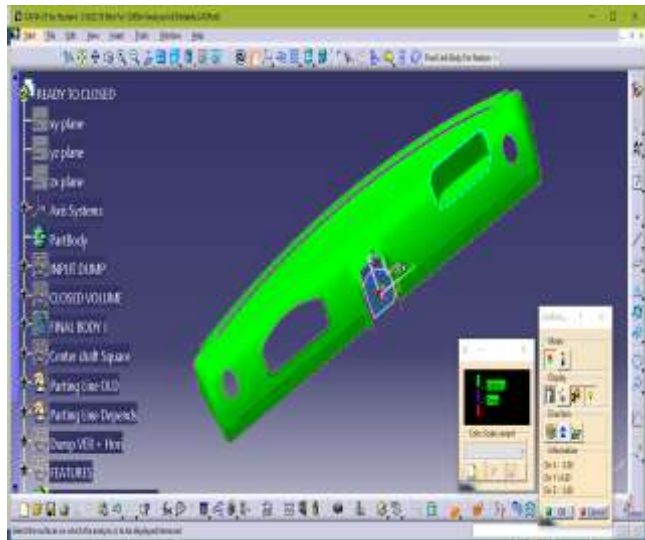

Fig.- 10 Concept 3 CAD Model (Clear in Draft)

Fig 9 is also modified simulations for tangency with joining distance 0.001mm. In following figure is taken in a mode shading with edges without smooth edges .in this mode the edges followed by tangency is not viewed. In following picture there is no sharp edges so all the required part followed by tangency.

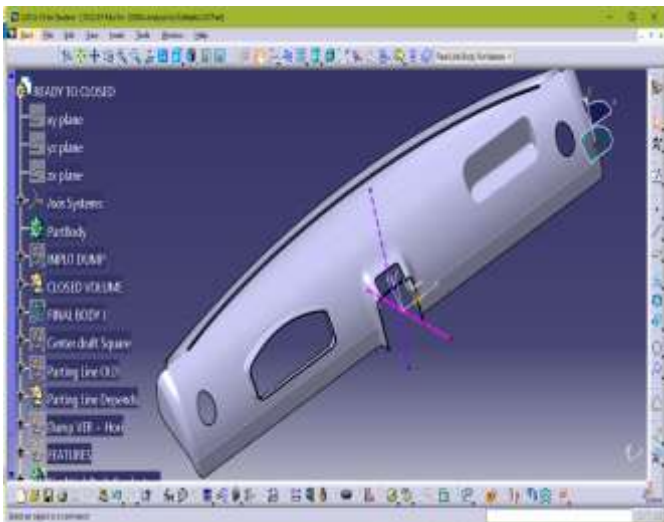

Fig- 11 concept 3 CAD Model (Follows Tangency)

In Above model designing From Visualization Model to Fully modified Cad model All the Criteria discussed in trade off analysis are completely followed. Like Whole Part is Clear in a Draft analysis in 0.48 degree (plastic part Standard guidelines) with feature in main tolling direction and on whole part Follows a tangency throughout. The thickness of a dashboard I have taken is 2.5mm with no variable thickness. To improve the stiffness of a part honeycomb ribs are added to the B side of a surface.



Fig -12 CAD Model (with Locating Features Follows tangency)

7. CONCLUSION

There were many factors which should be considered while designing automotive IP. Apart from the producing attractive designs, this study also focusing on ergonomic and safety design. In this Project I am developing a CAD Model by conceptual design then convert it into wireframes and surfaces using tool CATIA V5. I am done further modification in the model by following a plastic design trim guideline and successfully modified to clear in draft and follow tangency. Many other further modifications also done over it according to Plastic trim industry standard.

REFERENCES

- [1] M.D. Galer, The Application of Ergonomics in the Design of Automotive Displays, Butterworth & Co (Publishers) Ltd., 1984.
- [2] Market Report Plastics - March 2012 from http://plasticker.de/index_en.php website.
- [3] Lin Sun & XiaoMing Liu, Control Analysis of Production and Apparent Quality of Automobile
- [4] Plastic Design Guide: Part Design, Material Selection, Processing Conditions, <http://www.apisolution.com/plastic-design-guide.php> & Co (Publishers) Ltd., 1984.
- [5] Duotone. Steps used for designing packages in the packaging industry. Retrieved January 22, 2016, from <http://duotone2.com/process-steps-default/process-steps-packaging-design/>.
- [6] Automotive Product Design and Development of Car Dashboard Using Quality Function Deployment <http://dx.doi.org/10.4172/2167-7670.1000136>.
- [7] Global Automotive Plastics Market Size - Industry Report, 2018-2025 <https://www.grandviewresearch.com/industry-analysis/automotive-plastics-market>
- [8] Ing. Katarína Szeteiová , AUTOMOTIVE MATERIALS PLASTICS IN AUTOMOTIVE MARKETS TODAY .
- [9] Johanna Kaartinen A CHECKLIST FOR PLASTIC PRODUCT DESIGN, Preventing Pitfalls in a Design Process and Premature Failures of Plastic Products,

Company Supervisor: Markus Paloheimo, Sytyte Oy,
University of Skode.

[10] Reference Plastic Guidelines
<http://www.apisolution.com/plastic-design-guide.php>

BIOGRAPHIES



Jayesh Sudhakar Sarode
M-TECH (Machine Design)
JTMCOE, Faizpur



Dr. Atul Patil
Managing Director
IKSC Knowledge Bridge Pvt. Ltd.
Pune



Vijay Liladhar Firake
Assistant Professor
JTMCOE, Faizpur