

AIR AMBULANCE DRONE (UAV)

Mr. Sunil Bhosale¹, Mr. Shubham Shelar², Mr. Vikas Anandkar³, Mr. Swapnil Pawar⁴, Dr. Sreepad Sarange⁵.

^{1,2,3,4}Under Graduation student Department of Mechanical Engineering DYPSOET Pune, Maharashtra, India.

⁵Professor, Dept. of Mechanical Engineering, DYPSOET, Pune, Maharashtra, India.

Abstract - The transmitted to the emergency spot earlier than ambulance and take into account multiple real time health parameters of the patient such ambulance purpose of this project is to develop a prototype of drone ambulance to assist the ambulances in saving human life's. According to a study conducted by a centre of science and environment, traffic in its 'peak hours' on an average does not exceed 30-40 km/hr 92% of the times. In existing systems, a drone carries only the defibrillator to the emergency spot. Thus, it takes into account only a single parameter. This paper aims at developing a system that would be able to fly to the as temperature heart rate and heartbeat. The values of these essential parameters are then. This helps the doctor to evaluate the situation better to provide first-aid kit.

Key Words: Traffic¹, Peak Hour², Emergency Spot³, Heartbeat⁴, First-aid Kit⁵.

1. INTRODUCTION

In today's world, there is a lot of traffic in roads which leads to congestion in the whole city. So in the time of emergency critical situation. An ambulance which travels via road may not be able to reach the destination in time and the patient might lose his or her life. Thus, it is necessary to introduce a distinct means that would take the objective of saving human life one step closer. A drone or a hex copter takes aerial route and it's driven by human. Using more number of motors and propellers will produce thrust. The hex copter which consists of six BLDC Motors and propellers attached to it make it the optimal design and provide the necessary thrust. Power supply is 5200Mah battery is provided to the drone. The drone comprises of a medicine box which is capable reaching emergency situations faster than ambulance to help in emergency situation. The use drones in health is the purpose of the proposed prototype. For this reason, the first step is to develop a hexacopter. Both the thrust and the torque are produced by every hexacopter and it is produced about it's COR (centre of rotation). In addition to this a drag force is also produced in opposite direction to its flight.

1.1 Objective and Goals

The goal of our project, the air ambulance comes to the rescue situation, equipped with first aid and basic surgical kit. The air ambulance can reach the accident area within minutes and deploy necessary emergency supply. A GPS

module will be used to determine the current position and SD card will be used to store the information needed.

The use of drones in healthcare is the purpose of the proposed prototype. For this reason, the first step is to develop a hexacopter. Both the thrust and the torque are produced by every hexacopter and it is produced about it's COR (Centre of Rotation). In addition to this; a drag force is also produced in the opposite direction to its flight. Every hexacopter tries to achieve lift, yaw, roll and pitch via the thrust produced by the four motors attached to it. This way, the propellers fixed on the motors can be used for the flight of the hexacopter in all directions by differentiating the four rotors' thrust, the pitch and roll of the hexacopter can be controlled. The moment arm of each rotor's thrust about the CG, in steady state of the UAV should be equal.

2. CONSTRUCTION

The main components are used in hexacopter drone is as follows-

- 1) Frame :-HJ550mm Plastic Fiber Frame
- 2) Motors : Six 1000KV BLDC motors
- 3) Electronic speed controller(ESC): 30amp Simon
- 4) Flight Controller :Picxhawk flight controller
- 5) Battery :5200mAH Lipo
- 6) GPS module :M7N
- 7) Transmitter:FSi6 Flysky
- 8) Receiver:6 channel fsi6
- 9) Telemetry module :433MH
- 10) Propeller:10*4.5



Fig-1: Basic construction of Hexacopter

3. HEXACOPTER DESIGN

It is implementation of Quad copter for more stability and strength. The use of drone as air ambulance. For this reason, the first step is to develop a hexacopter.

Both the torque and thrust are produced by every hexacopter and it is produced about its COR (center of rotation). In addition to this a drag force is also produced in opposite direction to its Flights. Every hexacopter tries to achieve lift yaw, roll and pitch via the thrust produced by the six motors attached to it. This way, the propellers fixed on the motors can be used for the flight of the hexacopter in all direction.

By the differentiating the six rotor's thrust the pitch and roll of the hexacopter can be controlled. The moment arm of each rotor's thrust about the CG, in steady state of the UAV should be equal.

$$M = MI \times \alpha;$$

Simplifying, $T = m\alpha + mg;$

Differentiating, $dT/d\alpha = mr.$

Additionally, to increase stability, mass at the

Rotor (m) or the distance between the rotor and CG

(r) have to be increased.

For Yaw stability, two of the hexacopter's rotors

are counter-rotating, thus the reaction torque of two

rotors have been countered. Equating thrust and

weight, $3T\cos\theta = Mo \times g;$

Impulse-momentum principle, [3] $MI \text{ rotor} \times \alpha +$

$$3T\sin\theta.r = 0;$$

Simplifying, $\tan\theta = [mrm2\omega/2] / grMo;$

From the technical specifications of the motor, the

Maximum rotational speed of the motor is $\omega = 1900$

Rads-1. Thus $\theta = 0.43^\circ.$

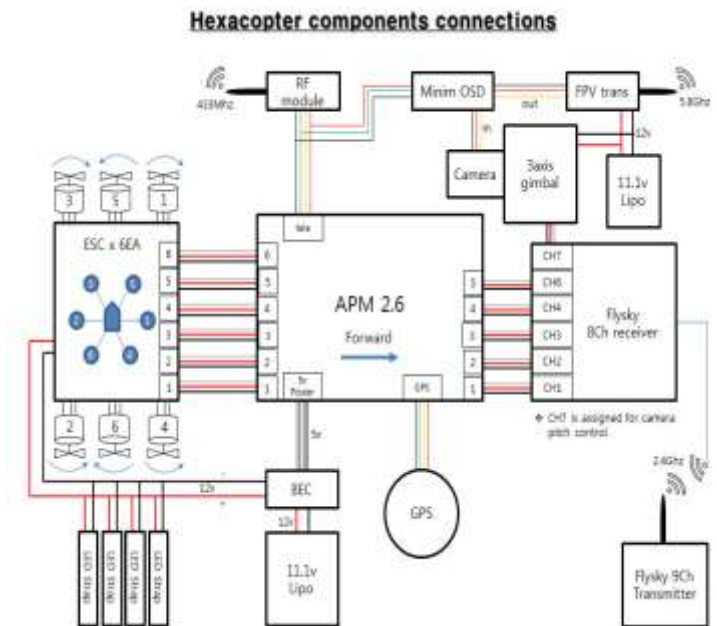

Fig-2: Connection diagram

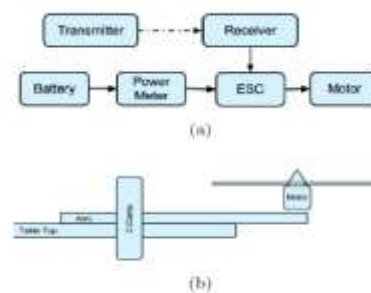

Figure 4.4: Motor & ESC test bench: (a) Block diagram. (b) Test bench.

Fig -3: Motor & ESC test Block diagram

4. CONCLUSIONS

A prototype of 'drone ambulance' is developed in order to assist ambulances in saving human lives. The developed prototype takes less time to reach the emergency situation spot and helps to measure and transmit real time health parameters of patient to the ambulance where they can be analyzed in the lab view software. This prototype helps in major irreplaceable contribution in saving the life of a patient and thus fulfils the purpose of 'lifesaving'

5. FUTURE SCOPE

The drone can be used in agriculture, industrial, photography area, military purpose. The metal detector system can be installing on a drone to find location of mines. The drone can be used in sprayer.

ACKNOWLEDGEMENT

With immense pleasure, I am presenting this Project report on “**AIR AMBULANCE DRONE (UAV)**” as part of the curriculum of B.E Mechanical Engineering.

I wish to thank all the people who gave me an unending support right from the stage the idea was conceived.

I take this opportunity to convey my sincere thanks to our beloved principal **Dr.Ashok Kasnale**, for his continual support and encouragement that made this Project a great success.

I express my profound thanks to our respected Head of the Department **Prof. Rahul Bachute** whose advice and valuable guidance helped me in making this Project interesting and successful one.

I am grateful to our internal guide **Dr. Shreepad Sarange** for his support and guidance throughout the course of this Project.

REFERENCES

[1] Josephin Arockia Dhivya ,Dr. premkumar “quadcopter based technology for an emergency healthcare”2017 3rd International conference on Biosignals ,images and instrumentation(ICBSII),16-18 March 2017.

[2] Josefin Lennartsson ,“Strategic placement Ambulance drones for delivering defibrillators to out of Hospital Cardiac Arrest Victims” KTH, School of Architecture and the built environment (ABE).Urban planning and environment ,Geoinformatic ,2015

[3] www.wikipedia.org