

Microcontroller based Anesthesia Injector

Smt.Leela Salim¹, Abey Thomas², Akshay M³, Athul K Alias⁴, Muhammed Irshad E K⁵

¹Assistant Professor, Dept. of Electrical and Electronics Engineering, Mar Athanasius College of Engineering, Kothamangalam, Kerala, India

^{2,3,4,5} Under Graduate Students, Mar Athanasius College of Engineering, Kothamangalam, Kerala, India

Abstract - In the hospitals when any major operation is performed, the patient must be in anesthetized condition. If the operation lasts for a long time, for suppose for 4 or 5 hours, complete dose of anesthesia cannot be administered in a single stroke. It may lead to the patient's death. If lower amount of anesthesia is administered, the patient may wake up at the middle of the operation. To avoid this, the anesthetist administers few milliliters of anesthesia per hour to the patient. If the anesthetist fails to administer the anesthesia to the patient at the particular time interval, other allied problems may arise. To overcome such hazardous problems the design of an automatic operation of an anesthesia machine based on a micro-controller is effective. In this system a microcontroller and syringe infusion pump provided. The anesthetist can decide the level of anesthesia in terms of milliliters per hour to administer anesthesia to the patient with the help of different sensor results. After receiving the signal from the sensors the microcontroller controls the signal to the desired level and fed into the dc motor to drive the infusion pump in proper manner. The anesthesia is administered to the patient according to the dc motor rotation.

KEY WORDS: Anesthesia, Microcontroller, Sensors, dc motor, Syringe infusion pump

1. INTRODUCTION

An Embedded system is a combination of computer hardware, software and additional mechanical parts designed to perform a specific function. An example is the microwave oven. It is hardly realized that the oven actually consists of a processor and the software running inside. Another example is the TV remote control. Very few actually realize that there is a microcontroller inside that runs a set of programs especially for the TV. Automatic Anesthesia Injector system is also an application of embedded technologies in which a microcontroller is used to control the entire device. A microcontroller is a general-purpose device that is meant to read data, perform limited calculations on that data and control its environment based on those calculations. The prime use of a microcontroller is to control the operation of a machine using a fixed program that is stored in ROM and that does not change over the lifetime of the system. A microcontroller is a highly integrated chip that includes all or most of the parts needed

for a controller in a single chip. The microcontroller could be rightly called a one-chip solution. If a system is developed with a microprocessor, the designer has to go for external memory such as RAM, ROM or EPROM and peripherals and hence the size of the PCB will be large to hold all the required peripherals. But, the micro controller has got all these peripheral facilities on a single chip and hence development of similar system with micro controller reduces PCB size and the overall cost of the design. The difference between a Microprocessor and Microcontroller is that a microprocessor can only process with the data, but Microcontroller can control external device in addition to processing the data. If a device has to be switched ON or OFF, external ICs are needed to do this work. But with Microcontroller the device can be directly controlled without an IC. A Microcontroller often deals with bits, not bytes as in the real world application, for example switch contracts can be open or close, indicators should be lit or dark and motors can be either turned on or off and so forth.

Microcontroller Based Anesthesia Injector Major operations are performed to remove or reconstruct the infected parts in the human body. These operations will lead to blood loss and pain. Therefore it is necessary to arrest the pain and the blood loss. Anesthesia plays an important role in the part of painkilling. AAI can be designed as Automatic administration of anesthesia based on the bio-medical parameters of the patient, eliminating future side effects and the need for an anesthetist. Anesthesia is very essential in performing painless surgery and so an Automatic administration of Anesthesia is needed for a successful surgery. At present anesthetist controlled manual operation is employed, which may cause many difficulties such as, Level of anesthesia may get varied and there is a chance of getting side effects in future. Suppose the anesthetist fails to administer the level of anesthesia during the predetermined period, the patient may be disturbed during the operation. Other systems developed to administer anesthesia operates by sensing the consciousness level of the patient and not by measuring his overall body conditions.[1]

2. WORKING

The system consists of 3 sensors in the input side where the inputs are fed to the analog to digital converter. The threshold values which are predetermined by manual supervision, are coded as the base code to the dc motor. Thus as the input is varied by the sensor input, the

microcontroller controls the motor through the driving circuit and the step output is obtained using the specified motor. The block diagram of the system is shown in figure.

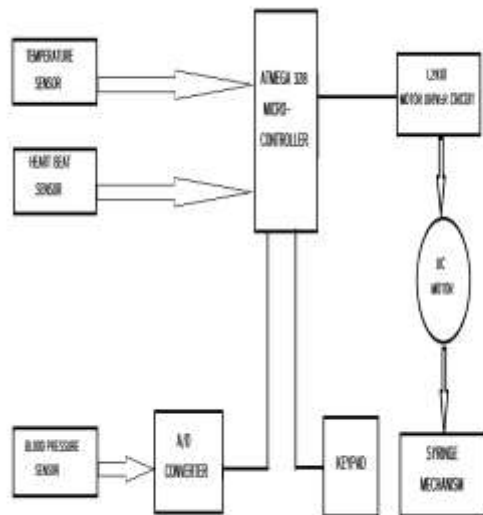

fig-1: Block diagram

Components used in the system are

1. Microcontroller to Control the overall operation
2. Temperature Sensor to measure body temperature
3. Blood pressure sensor to measure blood pressure
4. Heart Beat Sensor to measure heartbeat
5. DC Motor to control the movement of the Syringe Infusion Pump
6. Motor drive circuit to control dc motor
7. Arduino board

2.1 Microcontroller

The microcontroller used is ATmega328 powered by the Arduino UNO board .The high-performance Microchip 8-bit AVR RISC-based microcontroller combines 32KBISP ash memory with read-while-write capabilities, 1KB EEPROM, 2KB SRAM, Operating Voltage: 5V,Input Voltage (recommended): 7-12V,Digital I/O Pins: 14,Digital I/O Pins: 14.

2.2 Sensors

There are 3 sensors are used namely temperature sensor, pressure sensor, heartbeat sensor. From the input values attained from the 3 sensors, the microcontroller checks the threshold value.

Temperature sensor used is LM35.The LM35 series are precision integrated-circuit temperature sensors, whose output voltage is linearly proportional to the Celsius (Centi-

grade) temperature. It has very low self-heating, less than 0.1C in still air. The LM35 is rated to operate over a -55 to +150C temperature range.

Systolic blood pressure measurement done using blood pressure cuff with the help of MPX5050DP-ND transducer. Pressure is converted to equivalent voltage.

Heart beat is sensed using a sensor which employs optical finger plethysmographic technique. peak. The change in blood volume caused by the pressure pulse is detected by illuminating the skin with the light from a light-emitting diode (LED) and then measuring the amount of light either transmitted or reflected to a photodiode.

3.1 DC motor and driving circuit

DC motor is used for control of syringe infusion pump. A **DC motor** is any of a class of rotary electrical machines that converts direct current electrical energy into mechanical energy. The most common types rely on the forces produced by magnetic fields.

Driving circuit for controlling dc motor used is l293d according to signal from microcontroller. project.L293D is a typical Motor driver or Motor Driver IC which allows DC motor to drive on either direction. L293D is a 16-pin IC which can control a set of two DC motors simultaneously in any direction. (IC).It works on the concept of H-bridge. H-bridge is a circuit which allows the voltage to be own in either direction.

3.1 Syringe infusion pump

The Syringe Infusion pump provides uniform flow of fluid by precisely driving the plunger of a syringe towards its barrel. It provides accurate and continuous flow rate for precisely delivering anesthesia medication in critical medical care. It should be

- 1.Able to deliver the infusion accurately and consistently.
2. Easy to set up and use Portable and robust
3. Powered with battery and mains both
- 4.Equipped with override rapid infusion facility
- 5.Capable of alerting line occlusion and need to re-change syringe

4. SIMULATION

Simulation of the implemented system done in proteus software is given in the figure. Here the input side has only one sensor that is the temperature sensor. Sensor output is sent to arduino board. With the help of driving circuit the motor rotation is controlled.

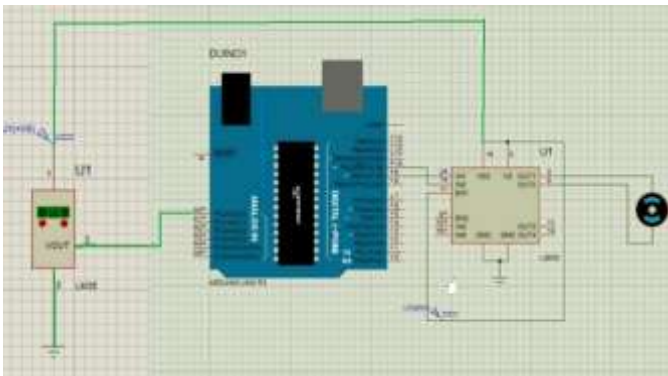

fig-4:Simulation in Proteus Software

5. PROGRAM FLOWCHART

Figure shows the Flow Chart for automatic anesthesia injector implemented using microcontroller.

The three sensors namely temperature sensor. Blood pressure sensor, heartbeat sensor. The values from these are measured using computer interface. They are crosschecked with the thresholds. Depending on the conditions the microcontroller can control the motor using drive circuit. If the conditions in the program are not satisfied there will be no change in dc motor rotation.

The anesthesia is injected by rotating the motor in both directions by drive circuit and appropriate delay second and other changes made in the arduino program by the user.

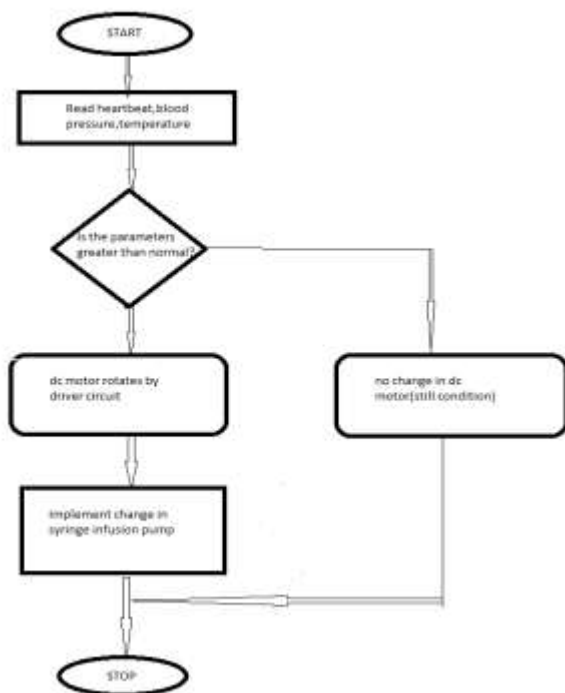

fig-5:flow chart

6. PROTOTYPE

This is the picture of the model using the above mentioned components. This system is generally administered for the case that the operation tends to extend for more hours as the operation is not completed. So there is a possibility that the patient might awaken. Thus the implemented system administers the anesthetic drug Bupivacaine 0.5 in the respective amount according to the time more required for the operation. Different drugs are administered according to the physique of the patient. Bupivacaine drug generally gives 4-5 hours for 4ml of administration.

The amount quantity of the drug is determined by the weight of the patient (0.05mg per kg). The standard syringe volume is selected and when 6 second delay time is given in the microcontroller, 4ml anesthetic fluid is administered according to the experimental results. From the input values attained from the 3 sensors, the microcontroller checks the threshold value and gives the control to the motor drive circuit according to the delay time provided. The heart beat sensor takes the heart beat pulse, threshold value being 80 pulse per min, temperature sensor threshold being 38 degree celsius, blood pressure sensor threshold being 24mV which is equivalent to 80mmHg. If the attained input value from the patient normally when awakened during the operation is above the proposed threshold, the microcontroller triggers the DC motor to drive the syringe infusion pump according to the delay time.



fig-6:Prototype of the model

7. EXPERIMENTAL RESULTS

The performance of the microcontroller was checked virtually by interfacing it with the computer. The program was written in the micro controller for analyzing the parameters. The threshold values of sensor parameters which are predetermined by manual supervision, are coded as the base code to the dc motor .DC motor will control the syringe infusion pump according to the program burned in arduino board

8. CONCLUSION

Microcontroller is made use to perform anesthesia injecting operation, where the quantity to be inject and the timing is provided. By using various electrical circuits the bio-medical parameters can be found. The output of the circuits is amplified by means of an amplifier and fed into an A/D converter. The digital signal is then fed into the input port of the Microcontroller. The Microcontroller displays the parameters in digital value in the display device. The parameters like temperature, respiration and heartbeat rate the stepper motor speed is varied. If the level of the temperature or respiration is increased or decreased the level of anesthesia was controlled automatically with the help of micro-controller and the stepper motor actions. Syringe infusion pump is mechanically connected to the motor. Making use of sensor it detects its destination where it need to inject then by precisely drives the plunger. Since the surgery time varies, externally it is reset or turned off_. Modern technologies have developed using embedded systems promoting comfortable and better life. MICROCONTROLLER BASED ANESTHESIA INJECTOR is one of the efficient systems plays its major role in Bio-Medical field. Using this system time management is obtained since the periodic interval is set using program. The measurement of bio-medical parameters is a vital process. These parameters determine the overall condition of the patient. It plays a very significant process in the level of anesthesia that has to be administered to the patient. The transducers used are just those that find applications inpatient monitoring systems and experimental work on four parameters namely blood pressure, temperature, pulse and respiratory activity, more precision might obtained if multiple parameters like retinal size, age and weight are considered.

REFERENCES

- [1] Engr Rana M shakeel, Microcontroller based anasthesia injector,2007
- [2] Kenneth J. Ayala,The 8051 microcontroller architecture, programming, and ap-plications, Indian reprint 2007, THOMSON Delmar learning
- [3] Moneypenny,When are human factors can't intubate oxygenate scenarios?.British journal of anesthesias 2017;118:469-9

- [4] G.C.L.Fletcher,McGeorge ,The role of non-technical skills in anesthesia:a review
- [5] Dr Lees N,When are human factors can't intubate oxygenate scenarios?,Anesthesia
- [6] wikipedia.org/anesthesia.