

DESIGN CONSTRAINTS OF AN RADIO FREQUENCY ENERGY HARVESTING

ANN SHIRLEY NATASHA¹, KISHORE KUMAR.U², G.PRAKSH RAM³, RAJAT SAHU⁴.

¹Student, Dept of EEE, SRM Institute of Science and Technology, India

²Student, Dept of EEE, SRM Institute of Science and Technology, India

³Student, Dept of Mechatronics ENGG, SRM Institute of Science and Technology, India

⁴Student, Dept of ECE, SRM Institute of Science and Technology, India

ABSTRACT - Free energy has been around for a long time now. This can be generated, using magnets, electromagnetic wave such as radio waves, and also using gravity. But also at the same time there is a misconception about free energy. Energy becomes free only after a point at which we don't have to pay for power generation after commissioning the unit. Finite electrical battery life has been encouraging a lot of companies and researchers to find alternatives for the usual power generation methods.

Radio frequency energy transfer and harvesting techniques are the alternative methods to power the next generation of wireless networks. RF energy harvesting techniques can power a whole new generation of devices and can prove to be a sustainable source of energy. This energy can thus be used in a range of applications such as mobile charging circuits, wireless body area networks, medical implant devices. This paper deals with the generation of radio frequency or RF energy harvesting system, and how it has developed over the years. Various elements that involve in generation and transmission of RF energy such as antenna, converters, and boosters are explained. Furthermore, different types of antenna designs have also been discussed. Antennas play an important role in converting the signal and transmitting it to the receiver. Impedance matching circuits which are required so as to allow the maximum amount of power transfer are discussed. Certain applications which are already implemented and the scope of development in this field of harvesting have been discussed. Further more in this paper we have discussed about different impedance matching circuits, feasibility and the future aspects of this technology.

Key Words: RF – Radio Frequency, LAN – Local Area Network,

1. INTRODUCTION

The technique of converting the available raw energy source into useful electrical energy is called as energy harvesting. Energy harvesting has been around for decades in the form of windmills, watermills and passive solar power systems. In recent years, technologies such as wind turbines, hydroelectric generators and solar panels have turned harvesting into a small but growing contributor to the world's energy needs. This technology offers two important advantages over the battery powered solutions, virtually

inexhaustible sources and a little or no adverse environmental effects. Recently, the availability of the free RF energy has increased due to emergence of wireless communication and broadcasting systems. Wireless power transmission technology via microwave has advanced from the 1960's. Until this time, the electrical power generated by RF energy harvesting techniques is small; depending on techniques it is enough to drive low power application devices. Therefore, it is possible to increase the battery life and to reduce the environmental pollution

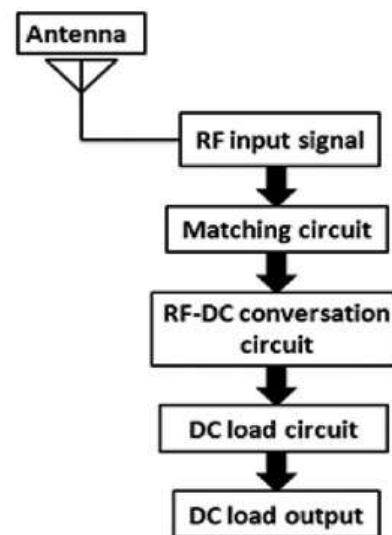

Fig-1: The energy flow chart of a RF energy harvesting system

With an upsurge of research interests in the radio frequency harvesting system^[1] which is the technique of converting the RF signals into electricity has become a promising source for the future generation of wireless electronics and devices. Radio waves are available in our everyday lives in form of signal transmissions from TV, radios, wireless LAN and mobile phones. This work is being carried out by many researchers for the following reasons: The energy is freely available in space. The energy harvesting device can be subdivided into three components: Antenna Design, RF-DC Conversion, Charging circuit. In RF energy harvesting, radio signals with frequency ranging from 300GHz to as low as 3

kHz be used as a medium to carry energy in the form of electromagnetic radiation. The device which is used to harvest RF energy is called 'Rectenna'. The first rectenna was designed by W. C. Brown [2]. Since then a lot of research work has been done. Rectenna is a rectifying antenna which is used to harvest RF signal, and then it converts the RF signal to DC output.

The most of the works are based on designing the suitable antenna for receiving the RF signal and increasing the efficiency of rectifier circuit. Fig shows the schematic diagram of an RF energy harvesting system.

The paper aims to provide a comprehensive detail on the RF energy harvesting technology and its evolution, the circuit design and various constraints. The design of various impedance matching circuit, various antennas for energy harvesting, applications and sources. Our research aims to help provide a blend of different designs and their feasibility. The various construction designs that can be utilized, the impedance matching circuits and the various antennas and their efficiency.

2. RF ENERGY HARVESTING

RF energy harvesting employs the conversion of electromagnetic energy to the electrical energy. It is important to have knowledge about both of these domains to make an RF energy harvester. This type of energy harvesting uses RF energy as a source and then converts this energy into electrical form. This energy is then stored and Utilized for low power application. Hence the Designing of RF energy harvesting system mainly concerns with the designing of antenna, then the rectifier design, and Finally DC-DC converter.

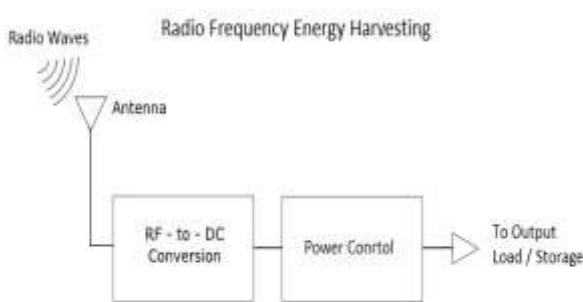

Fig-2: the basic block diagram of RF energy harvesting system

3. COMPONENTS

The main components of RF energy harvesting system are the antenna, impedance matching device, rectifier, dc to dc converter and then the battery for storage purposes. The system consisting of all these components is clearly shown in

fig 2. This entire block is commonly known as Rectenna which is basically an antenna followed by and rectifier.

To capture electromagnetic waves, such as radio waves for RF energy harvesting, it is important to choose the antenna properly. Antenna can work on wide range of frequencies. But the efficiency of the antenna depend upon its characteristics such as gain, polarization etc. The output of the antenna is low power ac output and this output is given to the rectifier circuit. The rectifier circuit consists of diodes and capacitors. Both ensure the proper conversion. The capacitor makes sure that the output is smoothly received by

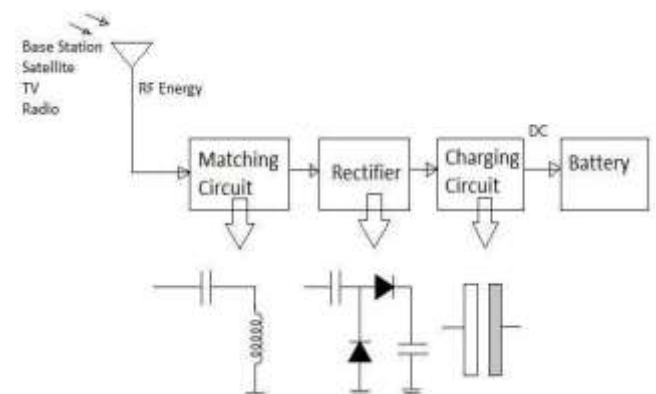

Fig-3: A basic rectenna circuit

the load end and also at times acts as a reserve whenever required. The ac to dc output is of low power, and hence to drive the load and battery sources it is boosted up by a converter circuit. Hence the entire efficiency of an RF energy harvesting circuit depends upon the overall efficiency of the antenna, the impedance matching circuit and also on the power converter circuits.

4. THE ANTENNA

An Antenna is the most important part of the RF energy harvesting system. Antennas are the basic components of any electrical circuit as they provide interconnecting links between the transmitter and the free space or between free space and receiver. As discussed earlier, antenna converts the Electromagnetic waves into electrical signals. This is basically an AC output, which is given to an AC-DC converter. The antenna can act as a receiving antenna or a transmitting antenna. The receiving antenna captures the RF energy signals and converts it into an ac output and the transmitting antenna takes up an ac signal and gives the RF output.

The characteristics of the antenna determine its overall performance. The size of the antenna depends upon its operating frequency. So in order to obtain higher efficiency, an appropriate antenna design is important. The characteristics of the antenna such as the antenna gain, bandwidth, polarization, length, aperture, polar diagram, directivity hereby play a prominent role in harvesting RF energy.

Properties of Antennas

- **Antenna Gain:** Antenna gain is a measure of the degree of directivity of antenna's radial pattern. It is ratio of the power radiated per unit surface is by the intensity radiated by an isotropic antenna.

$$G = (\text{power radiated by an antenna}) / (\text{power radiated by reference antenna})$$

- **Aperture:** It is defined as the area which transmits or receives the electromagnetic waves.
- **Directivity:** The concentration of power radiated at a particular direction is called as directivity.
- **Bandwidth:** Bandwidth is an important factor to decide the size of the antenna as it is closely related to frequency. It is known as the frequency range over which the antenna can operate that is transmit or receive radio waves.
- **Polarization:** Polarization can occur in two ways. one is vertical and other is horizontal.

As shown in Fig.4 when the electromagnetic wave is vertical is it said to be vertical polarization and when it is horizontal it is said to be horizontal polarization.

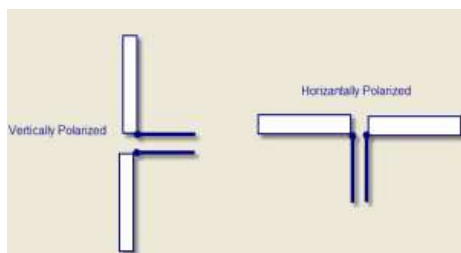

Fig-4: shows the horizontal and vertical ways of polarization

- **Polar diagram:** polar diagram tells us the effective area where the radiation is done by the antenna. We can thoroughly study the strength of the power radiated by an antenna in different angular directions. Fig shows an example of polar diagram [3].

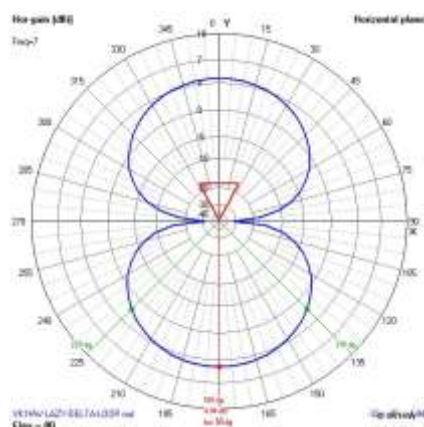

Fig-5: the polar diagram

Types of Antennas

The antennas mentioned below are the types of antenna used in RF harvesting, and certain antenna are explained in detailed below.

- **Log Periodic Antennae:** They are mostly preferred due to large bandwidth. This type of antenna consists of bow tie Antenna and log periodic antenna [4].
- **Wire Antenna:** Short dipole, dipole, Monopole, and loop antennas are some of the examples of this type of antenna
- **Travelling Wave Antenna:** Yagi-Uda antenna and helical antenna are the examples.
- **Microwave Antennas:** These types of antenna are majorly used. One is rectangular micro strip antenna and other is Inverted antenna [5].
- **Reflector Antennas:** Reflector type antennas are of two types they are corner reflector and parabolic reflector.

4.1 Log-Periodic Antennas

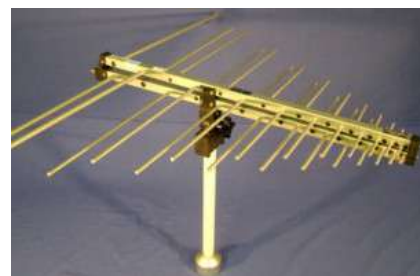

Fig-6: Log periodic antenna

This type of antenna is also called as a log periodic array. It is a multi-element, directional narrow beam antenna that works on a range of frequencies. This antenna is made of a series of dipoles placed along the antenna axis at different space intervals of time followed by a logarithmic function of frequency. Log-periodic antennas are used in a wide range of applications where variable bandwidth is required along with antenna gain and directivity. There are two different types of antenna one is bow tie, and other is dipole array shown in fig-8.

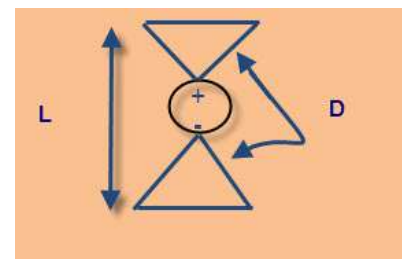

Fig-7: Bow tie antenna

Dipole type array: It is widely used in different applications. They have number of dipole elements, and their size reduces

towards the feed end, from the back end. The back end element operates in low frequency range, but the size of which is large. The spacing of these antennas does also reduce towards front end.

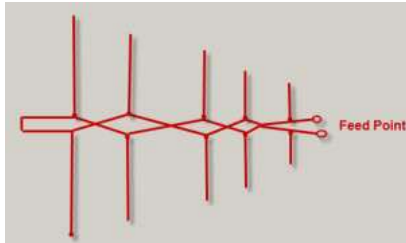

Fig-8: dipole array

A bow-tie antenna is also commonly known as Biconical antenna or Butterfly antenna. It is an omnidirectional wide-band antenna. According to the size of the antenna, it has a low-frequency response and acts as a high-pass filter. But when the frequency goes higher, it gets distorted.

4.2. WIRE ANTENNA

This type of antenna are known as linear or curved. They are also simple, cheap and also used in various applications. there are different types of wire antenna.

4.2.1 Dipole Antenna

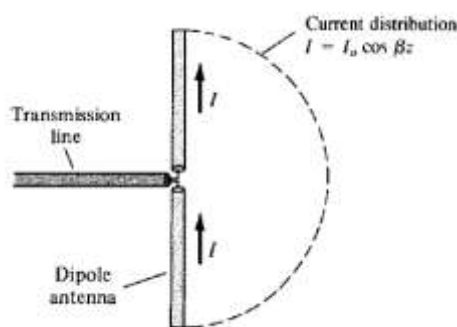

Fig-9: dipole antenna

The dipole antenna consists of two metallic rods through which the current and the frequency flow. This voltage and current flow makes an electromagnetic wave and the radio signals get radiated. The antenna consists of a radiating element that splits the rods and make the current flow through the center by using a feeder at the transmitter out that takes from the receiver. The different types of dipole antennas used as RF antennas are half wave, multiple, folded, non-resonant, and so on.

These types of antennas are available in two different types, one is half wave dipole and other is quarter wavelength. When the half wave dipole operates in half the wavelength of operating frequency they are called doublet.

4.3. TRAVELLING WAVE ANTENNA:

They differ through the other type of antenna in the travelling mechanism of this type of antenna. The radio frequency waves travel through only in one direction. They follow a single wave to travel which differs from the dipole or monopole type of antenna where the waves are reflected back and forth.

4.3.1 Helical Antennas



Fig-10: Helical antenna

Helical antennas are also known as helix antennas. They have a relatively simple structure with one, two or more wires each wound so as to form a helix. They are usually backed by a ground plane or shaped reflector and driven by an appropriate feed. The most common design is a single wire backed by the ground and fed with a coaxial line. In General the radiation properties of a helical antenna are associated with these specifications: the electrical size of the structure, wherein the input impedance is more sensitive to the pitch and wire size. Helical antennas have two predominate radiation modes: the normal mode and the axial mode. The axial mode is used for a wide range of applications. In the normal mode, the dimensions of the helix are small as compared to its wavelength. This antenna acts as a short dipole or monopole antenna. In the axial mode, the dimensions of the helix are the same when compared to its wavelength. This antenna works as directional antenna.

Diameter used in the of the wire of the antenna is about 1/3 of wavelength. The spacing between turns is 1/4 of wavelength. About 6-8 turns are generally used in such antennas. Ground plane reflector behind helix is usually of circular or square shape. This antenna is widely used in VHF/UHF range. The Gain and beam width of helical antenna is 12-20 dB and 12-45 deg. respectively.

4.3.2 Yagi-Uda Antenna

Another type of antenna that makes use of passive elements is the Yagi-Uda antenna. This type of antenna is inexpensive and effective. It can be constructed using one or more reflector elements and one or more director elements. These antennas can be made by using an antenna with one reflector which is placed at the rear of the driven element, a driven folded-dipole active element, basically this is a driven element where the feed line is attached from the transmitter

to yagi so as to transfer power to the antenna. The last elements are the directors mounted for horizontal polarization in the forward direction. Their length can vary, depending upon the director spacing, and the number of directors used.

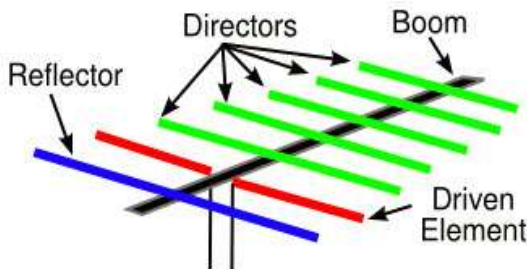

Fig-11: Yagi-Uda antennas

The reflector takes its main power from the driver, and reflects the radiation towards the directors, while doing so, the signal strength is also reduced. This signal is intercepted at the driven element which has a cable attached, that takes the received signal towards the receiver.

4.4 Microwave Antennas

The antennas which operate at microwave frequencies are known as microwave antennas. These types of antennas are used in a variety of applications. one such type of antenna is rectangular micro strip antenna which is explained below these types of antennas are widely used.

4.4.1 Rectangular Micro strip Antennas

These types of antennas are generally known as rectangular micro strip or patch antennas since they only require space for the feed line which is normally placed behind the ground plane

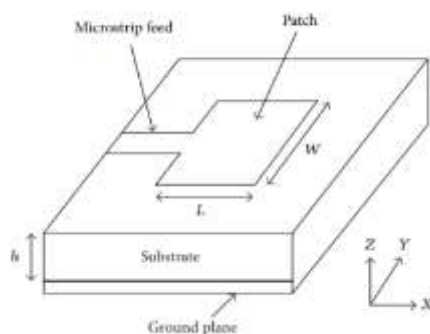

Fig-12: Basic structure micro-strip patch antenna

The patch used and take different shapes, rectangular, square, triangular, elliptical, dipole, circular, disc sector, ring sector, circular ring etc. Fig shows the different shows of the patch

This type of antenna have applications such as in aircraft or spacecraft applications – depending on various specifications such as the size, weight, cost, performance, ease of installation, etc. – low profile antennas are preferred. They find their applications in mobile satellite communications also. GPS systems and wireless LAN systems

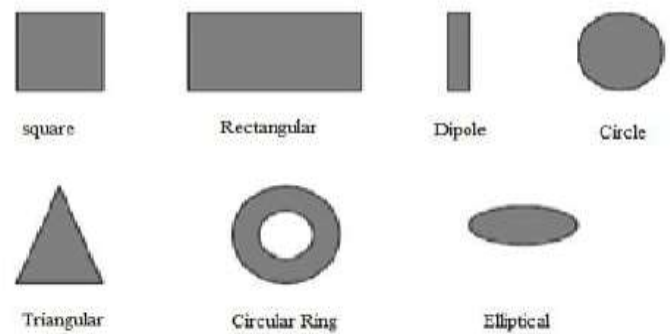

Fig-13: different shapes of patch

Some of the advantages are that they are technically easy to fabricate, since their size is less. They are economically feasible. They are generally easy to integrate with a microwave circuit. also, they can used in an array. They are also easy to feed. However they have disadvantages. The major disadvantages of using these antennas are their inefficient and very narrow bandwidth, which is typically a fraction of a percent or at the most a few percent. They also have low gain.

4.5. Reflector Antennas:

This type of antenna is called reflectors because they reflect electromagnetic waves. Two of them are corner reflector antenna and parabolic reflector antenna.

4.5.1 Corner Reflector Antenna

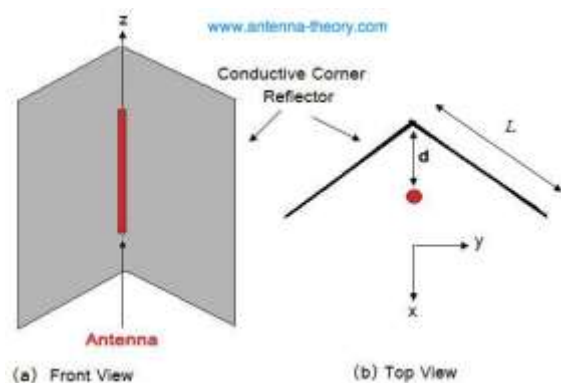

Fig-14: Corner reflector antenna

The antenna that comprises one or more dipole elements placed in front of a corner reflector is known as a corner-

reflector antenna. The directivity of any antenna can be increased by using reflectors. In case of a wire antenna, a conducting sheet can be used behind the antenna for directing the radiation in the forward direction.

4.5.2 Parabolic-Reflector Antenna

The radiating surface of a parabolic antenna has a very large dimension when compared to its wavelength. The geometrical optics, which depends upon rays and wave fronts, are used to know about certain features of these antennas. Some important properties of these antennas can be studied by using ray optics and of other antennas by using electromagnetic field theory.

Aperture of the parabola antenna is the area of outer circle of the parabola.

The area $A = 3.14 R^2$ Gain $G = 6 (D/\lambda)^2$

D is the diameter of dish antenna and λ is the wavelength

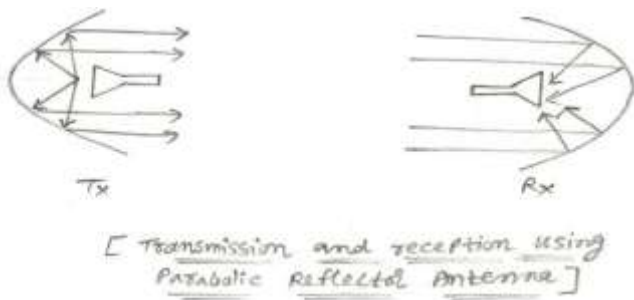

Fig-15: Parabolic antenna

One of the most useful properties of this antenna is the conversion of a diverging spherical wave front into parallel wave front which produces a narrow beam of the antenna. The various types of feeds that use this parabolic reflector include horn feeds, Cartesian feeds and dipole feed.

5 MATCHING NETWORK

A major part of the RF design is matching one part of a circuit to another part so as to provide maximum power transfer between the two parts. Even antenna design can be thought of as a matching impedance of free space to a transmitter or receiver. The crucial task of the matching network is to reduce the transmission loss from an antenna to a rectifier circuit and to increase the input voltage of a rectifier circuit. To this end, a matching network is generally made with reactive components such as coils and capacitors that are not dissipative. Maximum power transfer can be realized when the impedance at the antenna output and the impedance of the load are conjugates of each other. This procedure is known as impedance matching currently, there exists three main matching network circuits designed for RF

energy harvesting i.e. transformer, shunt inductor, LC network.

6 DIFFERENT IMPEDANCE MATCHING NETWORKS

6.1 L MATCHING CIRCUITS

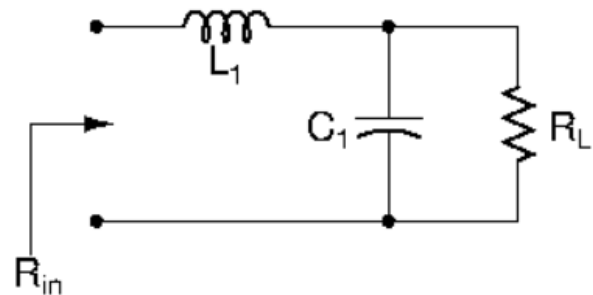

Fig 16 Series circuit

For Pass DC Current:

$$Z_{input} = \frac{RL + jxL + |j\omega c|}{j\omega L}$$

For Block DC Current:

$$Z_{input} = \frac{RL + jxL + [j\omega l]}{j\omega c}$$

The circuit gets its name because of the formation of an L shape by the capacitor and inductor to block the direct current the capacitor is placed near the source otherwise the inductor is placed near the source.

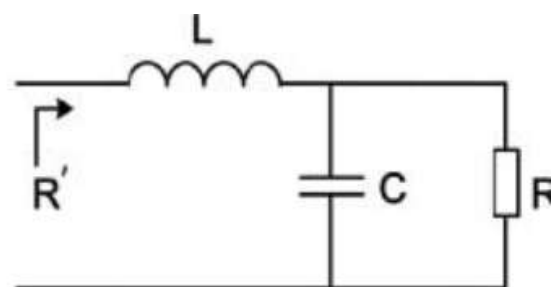

Fig-17: Shunt circuit

Advantages of L circuits:

- Simple and Low cost
- Easy to design

Disadvantages of L circuits:

- Q is determined by the ratio of R:R'
- No control over the value of Q.
- Bandwidth cannot be controlled.

6.2 PI MATCHING CIRCUITS

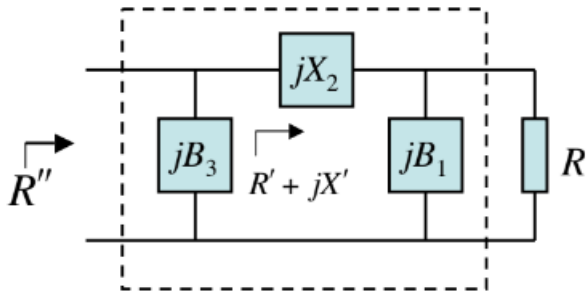

Fig-18: The pi matching impedance circuit is used to match impedance between 2 points.

6.3 T MATCHING CIRCUITS

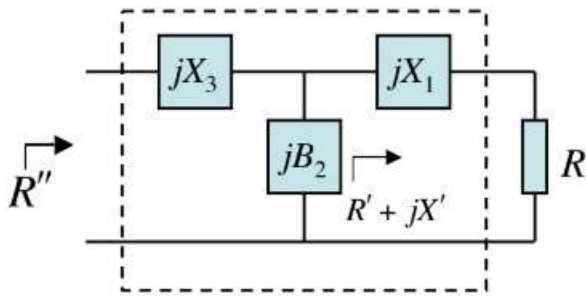

Fig-19: Tapped capacitor matching circuit

Advantages of π , T and tapped C circuits:

- specify Q factor (sharpness of cutoff)
- provide some control of the bandwidth

Disadvantage:

- No precise control of the bandwidth

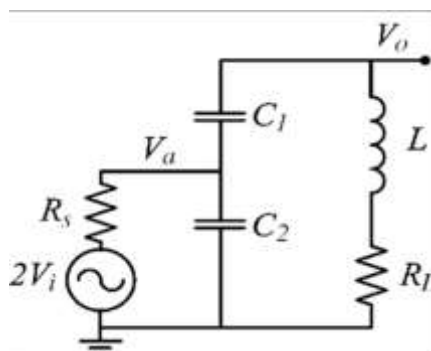

Fig-20: Tapped capacitor matching circuit

THE RECTIFIER

Rectifier is used to convert the RF signals which are AC signals into a DC voltage. Hence due to its important function, it is necessary to design an appropriate Rectifier.

The important part of a rectifier is a diode. It determines the efficiency of the RF-DC conversion. Commonly used diodes are the Schottky diodes.

Voltage multipliers use the schottky diodes for doubling the input voltage depending upon the number of stages used by the rectifier. These are used to increase the voltage in order to drive the load. This is basically followed by a DC-DC converter circuit so that the boosted up voltage can be stored in the batteries and then can be used to drive the load or other low power circuits. Single stage voltage multiplier and seven stage voltage multiplier is described in this section. Fig shows the diagram of the voltage doublers or a single stage voltage multiplier circuit. They use the combination of diodes and capacitors for the purpose. as the name suggests, the output voltage here is twice that of the input voltage. In positive half cycle, the positive half cycle is rectified. The capacitors are charged in the first half cycle, this input voltage is sent to the output rectifier in the next half cycle. Due to this operation, the output voltage is higher than the input voltage. It is twice in this case.

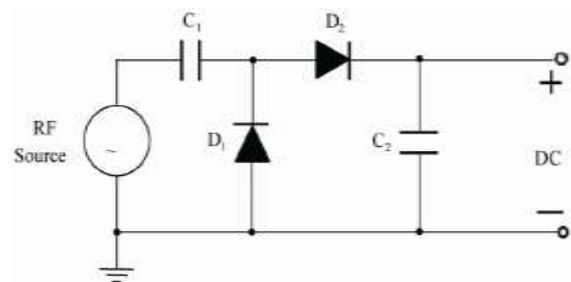

Fig-21: single stage voltage multiplier

7.1 Seven stage voltage multiplier

A seven stage voltage multiplier [6] is shown in the fig. There is a RF signal source in the left hand side of the circuit, followed by the voltage multiplier circuit. Number of voltage multiplier circuits is stacked together from left to right. This type of circuit uses schottky diodes, because they give low forward voltage and low substrate leakage. During ideal conditions, the flow of current is unidirectional due to the properties of the diode. The circuit has different capacitors at each stage, which are known as stage capacitors. A load

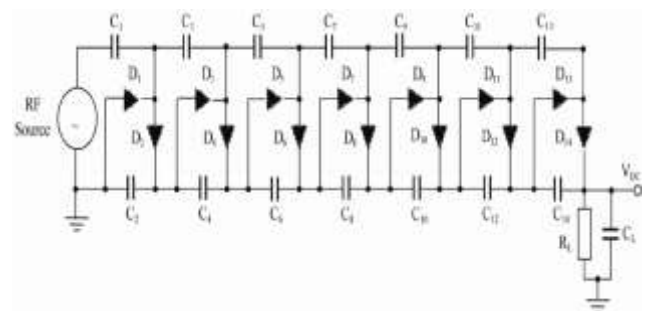

Fig-22: Seven Stage Voltage Multiplier

8. CONVERTERS

Converters are used to boost up the voltage of the rectifier. Generally the output of the rectifier is not sufficient enough to use for low power applications. Hence it is followed by a DC-DC converter circuit [9].

The buck-boost converter shown in the fig has a on-switch control block, it also has a bias and reference block, 100kHz ring oscillator circuit, and burst-mode control block. The main clock is generated by the internal circuit. This is the part that controls the operation of buck-boost converter. For smaller loads, the burst-mode timing circuit is included this maintains the efficiency of the converter [10].

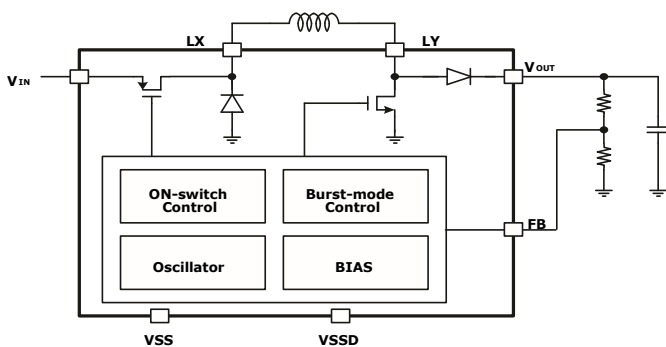

Fig-23: DC-DC converter

9. ADVANTAGES

Energy harvesting systems is technologically very viable. Over all the other traditional methods of energy generation such as thermal, mechanical etc RF provides an effective alternative method. The efficiency of the energy harvesting devices has increased gradually, especially while capturing energy from source which are ambient. Additionally, power consumption of engineered devices is reducing over time, with advancements in microprocessor technology. In combination of the above two facts, energy harvesting is becoming a great source for driving many low-power applications, potentially replacing current sources of power in the future.

Energy harvesting can be a maintenance-free alternative to battery technology. Since battery technology have a finite lifetime so their maintenance and replacements are required time to time. this makes the entire system to be costlier than the other methods. If RF energy is used as the source of power, the lifetime of the appliance may be unlimited if run with well-designed energy harvesting systems. If the source of the energy is guaranteed to available, energy harvesting systems can be used more reliably than battery and plug-based connections. Energy harvesting can be used as backup generator in power systems, which helps to improve the reliability and prevent power interruptions. Apart from being readily available for energy harvesting and unlimited

source if power, this energy if properly harvested can be a great sustainable source for the coming generation.

10. ENERGY SOURCES

The RF energy is most importantly a “free” energy. The number of radio transmitters, especially for mobile stations and handsets, continue to increase. Estimates are that the number of mobile phone subscriptions has surpassed 5 billion, and there are over 1 billion subscriptions for broadband. Mobile phones are one of the largest sources of transmitters which will enable users to provide power for a variety of close range sensing applications. Also, considering the number of Wi-Fi routers and wireless end devices such as laptops. In majority of urban areas, it is possible to detect a large number of Wi-Fi access points from one location for short range. it is possible to harvest a small amount of energy from a Wi-Fi router transmitting at a power level of 50 to 100 mW. For a long-range operation, large antennas are needed with high gain for practical harvesting of RF energy from mobile stations and broadcast radio towers.

The RF sources mainly can be classified into two types, i.e., dedicated RF sources and ambient RF sources.

10.1 Dedicated RF sources

Dedicated RF sources can be used in order to provide whenever there is a need of more predictable energy supply. The dedicated RF sources can use the license-free ISM frequency bands for the RF energy transfer. The Power caster transmitter working on 915MHz with 1W or 3W transmit power is a case of a devoted RF source, which has been popularized. Be that as it may, sending the committed RF sources can acquire greater expenses for the system. Also, the yield intensity of RF sources need be constrained by guidelines, for example, Federal Communications Commission (FCC) because of security and wellbeing worry of RF radiations. For instance, in the 900MHz band, the most extreme edge is 4W. Indeed, even at this peak setting, the power received at a little separation of 20m is constricted down to just 10 μ W. Because of this constraint, maybe man committed RF sources ought to be conveyed to satisfy the client need. In various RF energy transmission plans for portable power transmitters to renew remote sensor systems are researched.

10.2 Ambient RF sources:

Ambient RF sources refer to transmitters which are not expected for RF energy transfer.. This RF energy is basically free. The transmit power of ambient RF sources differs altogether, from around 106W for TV tower, to about 10W for cellular and RFID systems, to generally 0.1W for versatile specialized gadgets and Wi-Fi systems. Ambient RF sources

can additionally be grouped into static and dynamic ambient RF sources.

intelligent so as to search for energy harvesting opportunities in a certain frequency range.

11. CONCLUSION

Realizing the immense potential that lies behind this technology and the way it can prove to be a new source to power the next generation of devices. The practical use of RF energy harvesting can be observed in wireless body area network, wireless implantable medical devices, RF id for long range operations the power can be used in battery-based or battery free remote sensors for HVAC control and building automation, structural monitoring, industrial control .Wireless body area network etc.

With the world population expected to reach 10 billion by the year 2050, the world population will face an aging problem and a rise in health care costs. With the ever increasing risk of deadly diseases and to monitor their wireless body area network or body area networks will play a major role. Millions of people die every year from diseases such as asthma, cancer, diabetes, cardiovascular diseases, Parkinson’s due to the late symptoms that are associated diseases. With the introduction of wireless body area networks it is possible to develop a sustainable , wearable or a portable technology which can be used to detect the environment of the human body and tell about symptoms and abnormal conditions at an early stage. WBAN’s have the ability to interact over Bluetooth , internet , wireless area networks over a wide data exchange rate of up to 75 mbps opening the doors for intelligent and autonomous applications reducing the health care costs by decreasing the needs of the costly monitoring systems in the hospital.

Depending on the required power and system operation, power can be sent continuously, on a scheduled basis, or on-demand. This power is best suited for devices with low-power consumption and long or frequent charge cycles. Typically, the devices that operate for weeks, months, or years on a single set of batteries are good candidates for being charges wirelessly by RF energy. In some applications simply augmenting the battery life or offsetting the sleep current of a microcontroller is enough to justify adding RF-based wireless power and energy harvesting technology.

12. REFERENCES

1. H. J. Visser and R. J. M. Vullers, “RF energy harvesting and transport for wireless sensor network applications: principles and requirements,” Proceedings of the IEEE, vol. 101, no. 6, pp. 1410-1423, June 2013.

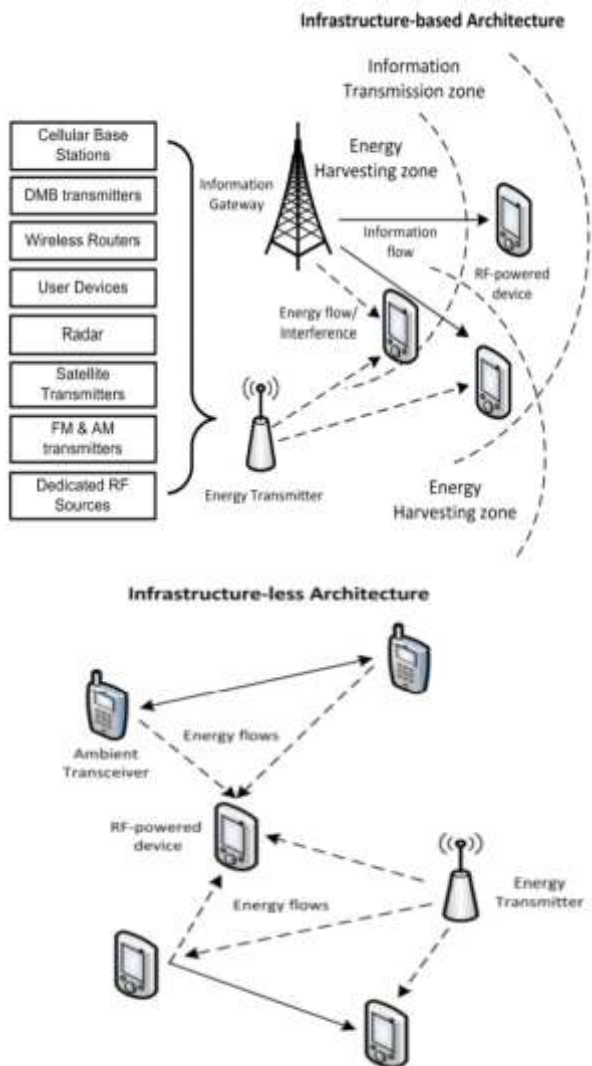

Fig-24: Infrastructure based architecture

Static ambient RF sources are the transmitters that discharge generally stable power after some time, for example, TV and radio towers. Despite the fact that the static ambient RF sources can give unsurprising RF energy, there could be long term and short term fluctuations. The power density of the ambient RF sources at different frequency bands is small and hence there is a requirement of a high gain antenna for all frequency bands. Also the rectifier should be designed for wideband spectrum. Dynamic ambient RF sources are the transmitters that work periodically. The RF energy harvesting from the dynamic ambient RF sources has to be adaptive and possibly

1. "IEEE Standard Definitions of Terms for Antennas". 145-1993. (1993). doi:10.1109/ieeestd.1993.119664
2. Bevelaqua, Peter J. "Types of Antennas". Antenna Theory. Antenna-theory.com. Archived from the original on 30 June 2015. Retrieved 28 June 2015. Peter Bevelaqua's private website.
3. Aksoy, Serkan (2008). "Antennas" (PDF). Electrical Engineering Department. Lecture Notes-v.1.3.4. Gebze, Turkey: Gebze Technical University. Archived from the original (PDF) on 22 February 2016. Retrieved 29 June 2015.
4. Devi, K. K. A., Norashidah, M. D., Chakrabarty, C. K., & Sadasivam, S. (2012). Design of an RF-DC conversion circuit for energy harvesting. 2012 IEEE International Conference on Electronics Design, Systems and Applications (ICEDSA). doi:10.1109/icedsa.2012.6507787 Publication Year: 2012, Page(s):156 - 161
5. Kasi Annapurna Devi, Kavuri & Din, Norashidah & Chakrabarty, Chandan. (2012). Optimization of the Voltage Doubler Stages in an RF-DC Converter Module for Energy Harvesting. Circuits and Systems. 03. 216-222. 10.4236/cs.2012.33030.
6. Ali, Esraa & Yahaya, Nor Zaihar & Nallagownden, Perumal & Zakariya, Mohd. (2014). DESIGN OF RF TO DC RECTIFIER AT GSM BAND FOR ENERGY HARVESTING APPLICATIONS. platform - A Journal of Engineering, Science and Society. 10.
7. Adami, S.-E., Marian, V., Degrenne, N., Vollaie, C., Allard, B., & Costa, F. (2012). Self-powered ultra-low power DC-DC converter for RF energy harvesting. 2012 IEEE Faible Tension Faible Consommation. doi:10.1109/ftfc.2012.6231746
8. Salah-Eddine Adami, Nicolas Degrenne, Christian Vollaie, Bruno Allard, Francois Costa. Ultra-Low Power, Low Voltage, Autonomous Resonant DC-DC Converter for Wireless Sensors. 4th IEEE POWERENG, May 2013, Istanbul, Turkey. IEEE, Proceedings of the 4th International Conference on Power Engineering, Energy and Electrical Drives, .
9. Lu, X., Wang, P., Niyato, D., Kim, D. I., & Han, Z. (2015). Wireless Networks With RF Energy Harvesting: A Contemporary Survey. IEEE Communications Surveys & Tutorials, 17(2), 757-789. doi:10.1109/comst.2014.2368999
10. Visser, H. J., & Vullers, R. J. M. (2013). RF Energy Harvesting and Transport for Wireless Sensor Network Applications: Principles and Requirements. Proceedings of the IEEE, 101(6), 1410-1423. doi:10.1109/jproc.2013.2250891
11. H. Nishimoto, Y. Kawahara, T. Asami, "Prototype implementation of ambient RF energy harvesting wireless sensor networks", Proc. IEEE Sens..
12. C. Mikeka, H. Arai, "Design issues in radio frequency energy harvesting system" in Sustainable Energy Harvesting Technol.—Past Present Future, Rijeka, Croatia: InTech, pp. 235-257, Dec. 2011.
13. W. C. Brown, "Experiments involving a microwave beam to power and position a helicopter", IEEE Trans. Aerosp. Electron. Syst., vol. AES-5, no. 5, pp. 692-702, Sep. 1969.
14. M. Al-Lawati, M. Al-Busaidi, Z. Nadir, "RF energy harvesting system design for wireless sensors", Proc. IEEE Int. Multi-Conf. SSD, pp. 1-4.
15. Movassaghi, S., Abolhasan, M., Lipman, J., Smith, D., & Jamalipour, A. (2014). Wireless Body Area Networks: A Survey. IEEE Communications Surveys & Tutorials, 16(3), 1658-1686. doi:10.1109/surv.2013.121313.00064
16. Y. Zuo, "Survivable RFID systems: issues, challenges, and techniques," IEEE Transactions on Systems, Man, and Cybernetics, Part C: Applications and Reviews, vol. 40, no. 4, pp. 406-418, July 2010
17. S. Kitazawa, H. Ban, and K. Kobayashi, "Energy harvesting from ambient RF sources," in Proc. of IEEE International Microwave Workshop Series on Innovative Wireless Power Transmission: Technologies, Systems, and Applications (IMWS), pp. 39-42, Kyoto, Japan, May 2012.
18. A. Aziz, A. Mutalib, and R. Othman, "Current developments of RF energy harvesting system for wireless sensor networks," Advances in Information Sciences
19. M. Pinuela, P. D. Mitcheson, S. Lucyszyn, "Ambient RF energy harvesting in urban and semi-urban environment", IEEE Trans. Microw. Theory Tech., vol. 61, no. 7, pp. 2715-2726, Jul. 2013.
20. W. C. Brown, "The history of power transmission by radio waves", IEEE Trans. Microw. Theory Tech., vol. 32, no. 9, pp. 1230-1242, Sep. 1984.
21. C. Mikeka, H. Arai, "Design issues in radio frequency energy harvesting system" in Sustainable Energy Harvesting Technol.—Past Present Future, Rijeka, Croatia: InTech, pp. 235-257, Dec. 2011.
22. M. Al-Lawati, M. Al-Busaidi, and Z. Nadir, "RF energy harvesting system design for wireless sensors," in Proc. of IEEE International Multi-Conference on Systems, Signals and Devices (SSD), pp. 1-4, Chemnitz, German, March 2012.
23. A. Al-Khayari, H. Al-Khayari, S. Al-Nabhani, M. M. Bait-Suwailam, and Z. Nadir, "Design of an enhanced RF energy harvesting system for wireless sensors," in Proc. of IEEE GCC Conference and Exhibition (GCC), pp. 479-482, Nov. 2013.
24. HONG, S. S. B. – IBRAHIM, R. B. – KHIR, M. H. M. – ZAKARIYA, M. A. B. – DAUD, H.: Wi-Fi energy harvester for low power RFID application, Progress in Electromagnetics Research C, Vol. 40, pp. 69-81, 2013.
25. OLGUN, U. – CHEN, C. C. – VOLAKIS, J. L.: Design of an efficient ambient Wi-Fi energy harvesting

system, IET Microwaves, Antennas & Propagation, Vol. 6, No. 11, pp. 1200-1206, Aug. 2012.

26. HONG, H. – CAI, X. – SHI, X. – ZHU, X.: Demonstration of a highly efficient RF energy harvester for Wi-Fi signals, Microwave and Millimeter Wave Technology (ICMMT), 2012
27. ARRAWATIA, M. – BARGHINI, M. S. – KUMAR, G.: RF energy harvesting system from cell towers in 900MHz band, Communications (NCC), National Conference, pp. 1-5, Jan. 2011.