

# GMPPT USING PSO AND GSO FOR PHOTOVOLTAIC APPLICATIONS

K. Ravichandiran<sup>1</sup>, N. Narmadhai<sup>2</sup>

<sup>1</sup>M.E II year, Department of EEE, Government College Technology, Coimbatore, India

<sup>2</sup>Associate Professor, Department of EEE, Government College Technology, Coimbatore, India

**Abstract** - In order to extract the maximum power point tracking (MPPT) technology is essential for photovoltaic systems are effective under uniform and non-uniform irradiance. The glowworm detecting method is implemented in GMPPT strategies combining conventional particle swarm optimization algorithm and Glowworm Swarm Optimization algorithm (GSO). The proposed algorithm is reduced to power oscillations and time. The performance of GSO algorithm is compared with conventional Particle Swarm Optimization (PSO) algorithm by utilizing MATLAB/SIMULINK environment.

**Key Words:** Glowworm Swarm Optimization (GSO), Particle Swarm Optimization (PSO), Maximum Power Point Tracking (MPPT) and Photovoltaic (PV) system.

## 1. INTRODUCTION

The limited stock of conventional energy sources such as Fossil fuel based power plants cause pollution which is harmful to the environment. There is a growing need for finding alternate methods of solar power generation using new method of GMPPT technique. The global energy growth and development of Clean and Renewable Energy sources, solar radiation is freely available, and can be directly observed by the use of photovoltaic modules [1]. The main problem associated with any GMPPT algorithm based on PSO is deciding when to restart the tracking process to adjust to dynamic system conditions (load change). Generally, if the measured power is varying greater than a predefined limit, then the tracking algorithm is restarted. If this limit is kept very small, the tracking needs to explore the entire search space even for small variations in load. This results in large variations in the operating power and thereby reduced system efficiency [2]. The basic conception of most electric outlet pursuit (MPPT) is to regulate the in operation purpose of a device up to the maximum in real time specified the system will perpetually operate at the most electric outlet (MPP). During this manner, MPPT improves conversion potency and reduces power loss. However, the MPP changes with the variable external environment, thereby any complicating the most power pursuit drawback. Thus, this algorithmic program is straight forward to develop. It works by imposing a hard and fast step perturbation on a reference voltage or current, output power of the PV system, and scrutiny the values before and when disturbance to work out the direction of the disturbance for successive step. If PV power will increase, then the direction of the disturbance is that the same as that within the last step (i.e., the system is

moving towards the MPP); otherwise, the direction is opposed. In recent years, many MPPT methods had been proposed. A detailed explanation and classification of MPPT techniques are made by Subudhi and Pradhan [3]. Among this method, the most commonly used approaches are perturb and observe (P&O) [4]. In order to extract the maximum power under varying conditions, a maximum power point tracking (MPPT) scheme is generally adopted [5].

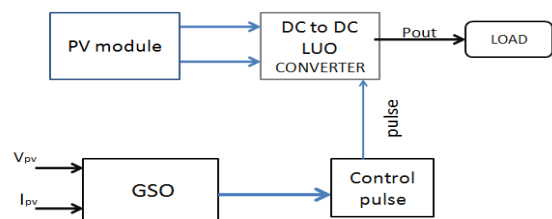


Fig -1: Typical block diagram of MPPT using GSO

Glowworm Swarm Optimization (GSO), which is a new type of bioluminescence glowworms algorithm, shows superior performance in deals with nonlinear problems, although this approach has to be applied in PV systems. In this work, the GSO algorithm is used to tracking the MPPT of a PV system. To evaluate the performance of the algorithm, the proposed GSO based MPPT method is implemented on a LUO converter (boost operation) shown Fig.1, and its performance is compared with that of the conventional PSO algorithm.

Equivalent circuit models define the entire IV curve of a cell, module, or array as a continuous function for a given set of operating conditions. One basic equivalent circuit model in common use is the single diode model, which is derived from physical principles and represented by the following circuit for a single PV cell shown below Fig.2

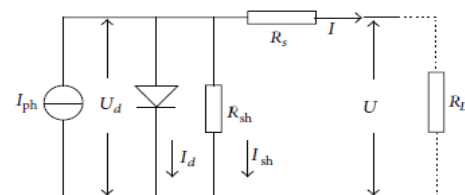


Fig -2: Equivalent circuit of a PV cell

## 2. LUO CONVERTER MODEL

Voltage lift technique is a popular method widely used in electronic circuit design. The effect of parasitic elements limits the output voltage and power transfer efficiency of DC-DC converters. Voltage lift technique opens a great way to improve circuit characteristics. LUO-converters are a series of new DC-DC step-up converters, which were implemented from prototypes using voltage boost technique are self lift positive output of LUO converter.

The proposed system consists of a Vdc from PV at the input stage and LUO converter at the regulating stage. The DC serves as input to the LUO converter, the LUO converter is controlled by a closed loop feedback system, which generates Switching pulses for the power electronic switch in the converter. The control circuitry uses PWM generator to produce the switching pulses.

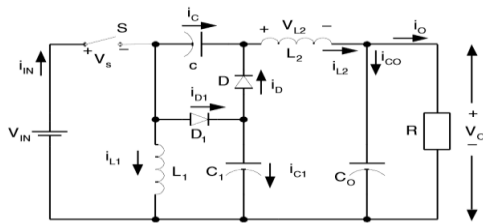


Fig -3: Self Lift Positive output LUO converter

The duty cycle of the LUO converter is varied according to the output voltage hence regulation of the voltage is achieved. The output of LUO converter is again filtered using an (L-C) filter. The required voltage rating of the LUO is given as below to the control system which is continuously compared with LUO converter output for voltage regulation. The circuit diagram and simulation diagram of self lift positive output LUO converter is shown in fig.3&4.

When switch S is on, the instantaneous source current is  $i_1 = i_{L1} + i_{L2} + i_{C1}$ . Inductor L1 absorbs energy from the source. In the mean time inductor L2 absorbs energy from source and capacitor C. Both currents  $i_{L1}$  and  $i_{L2}$  increase, and C1 is charged to  $V_{C1} = V_1$ . When switch S is off, the instantaneous source current is  $i_1 = 0$ . Current flows through capacitor C1 and diode D to charge capacitor C. Inductor L1 transfers its stored energy to capacitor C. In the mean time, current  $i_{L2}$  flows through the (CO - R) circuit, capacitor C1 and diode D, to keep itself continuous. Both currents  $i_{L1}$  and  $i_{L2}$  decrease. Assuming that capacitor C1 is sufficiently large, voltage  $V_{C1}$  is equal to  $V_1$  in steady state. Current  $i_{L1}$  increases in switch-on period  $kT$ , and decreases in switch-off period  $(1 - k) T$ . The corresponding voltages applied across L1 are  $V_1$  and  $-(V_C - V_1)$  respectively.

$$V_o = V_{in} / (1 - k) T \quad (1)$$

$$I_o = (1 - k) I_1 \quad (2)$$

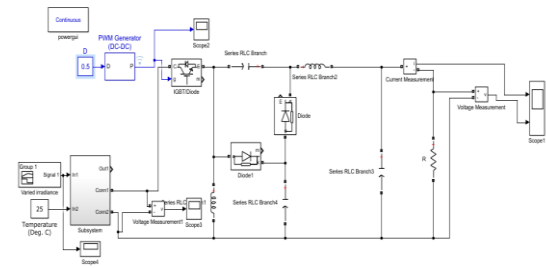


Fig -4: Simulation of LUO converter

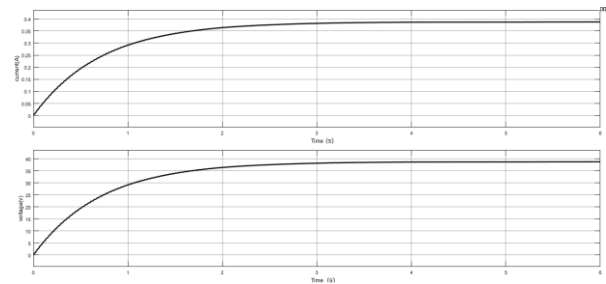


Fig -5: Output current and voltage of LUO converter

Fig.5. shows the output current and voltage of the LUO converter at constant D. Then input voltage of LUO converter 12 Vdc from PV panel output voltage converter boosted 38 Vdc

## 3. GLOWWORM SWARM OPTIMIZATION ALGORITHM

Glowworm Swarm Optimization (GSO) Algorithm has been based on the behavior of glowworms, which are position to modify their light emission and use the bioluminescence glow for different purposes). This work apply the GSO algorithm to determine the optimum value of a reference voltage in the Photovoltaic system.

The GSO algorithm, which is an advanced model of stochastic and metaheuristic optimization of MPPT algorithm, was first proposed by Krishnanand N.Kaipa, Debasish Goose. GSO uses a swarm of glowworms as its agents, which are regarded as the potential solutions to a problem. The fitness of optimality is measured by the objective function defined by users. In the present work, GSO is adopted to generate an optimum reference voltage that varying with radiance to the maximum power from the PV system. Glowworm algorithm is an optimization method is easy to implement with a rapidly convergence few parameters to adjust.

### 3.1 Description of the Algorithm

The GSO algorithm is based on glowworms, each of which is consider a potential solution to the given objective problem. In the first stage, a swarm of glowworms is randomly distributed in a search space with an initial

luciferin value, which determines the brightness of the glowworms.

### 3.2 Luciferin update phase

The luciferin update depends on the function value at the glowworm position. During the luciferin-update phase, each glowworm adds, to its previous luciferin level, a luciferin quantity proportional to the fitness of its current location in the objective function space. Also, a fraction of the luciferin value is subtracted to simulate the decay in luciferin with time. The luciferin update rule is given by:

$$L_i(t+1) = (1 - \rho)l_i(t) + J_i(t+1) \quad (3)$$

where,  $L_i(t)$  represents the luciferin level associated with glowworm  $i$  at time  $t$ ,  $\rho$  ( $0 < \rho < 1$ ) is the luciferin decay constant and  $J(x_i(t))$  represents the value of the objective function at glowworm  $i$ 's location at time  $t$ .

### 3.3 Movement phase

During the movement phase range, all glowworm decides, using a probabilistic mechanism, to move toward a neighborhood range that has a luciferin value greater than its own. They are five glowworms means ( $a, b, c, d$  and  $e$ ) that have relatively higher luciferin level than glowworm  $f$ . Since  $f$  is located in the sensor-overlap region of  $d$  and  $e$ , it has only two possible directions of movement. For each and every glowworms  $i$ , the probability of moving toward a neighbor  $j$ .

### 3.4 Neighborhood range update phase

During neighbor range each agent  $i$  is associated with a neighbor whose radial range dismiss is dynamic in nature ( $0 < r_{id} \leq r_s$ ). The fact that a fixed neighborhood range update is not used need some justification. When the glowworms depends only on local information to determine their movement range, it is expect that the many number of peaks captured would be a function of the radial sensor range. In fact, if the sensor range of each agent covers the entire search space, all the agents move to the global optimal and the local optimal are ignored. Since we assume that a priority information about the objective function (e.g., number of peaks and inter-peak ranges) is not available, it is tough to fix the neighbor range at a value of works perfect for different function landscapes. For instance, a chosen neighborhood range  $r_d$  would work depends better on objective functions where the minimum inter-peak distance is greater than  $r_d$  rather than on those where it is lesser than  $r_d$ . Therefore, GSO uses an adapt neighbor range in order to determine the maximum number of peaks in a multimodal function landscape.

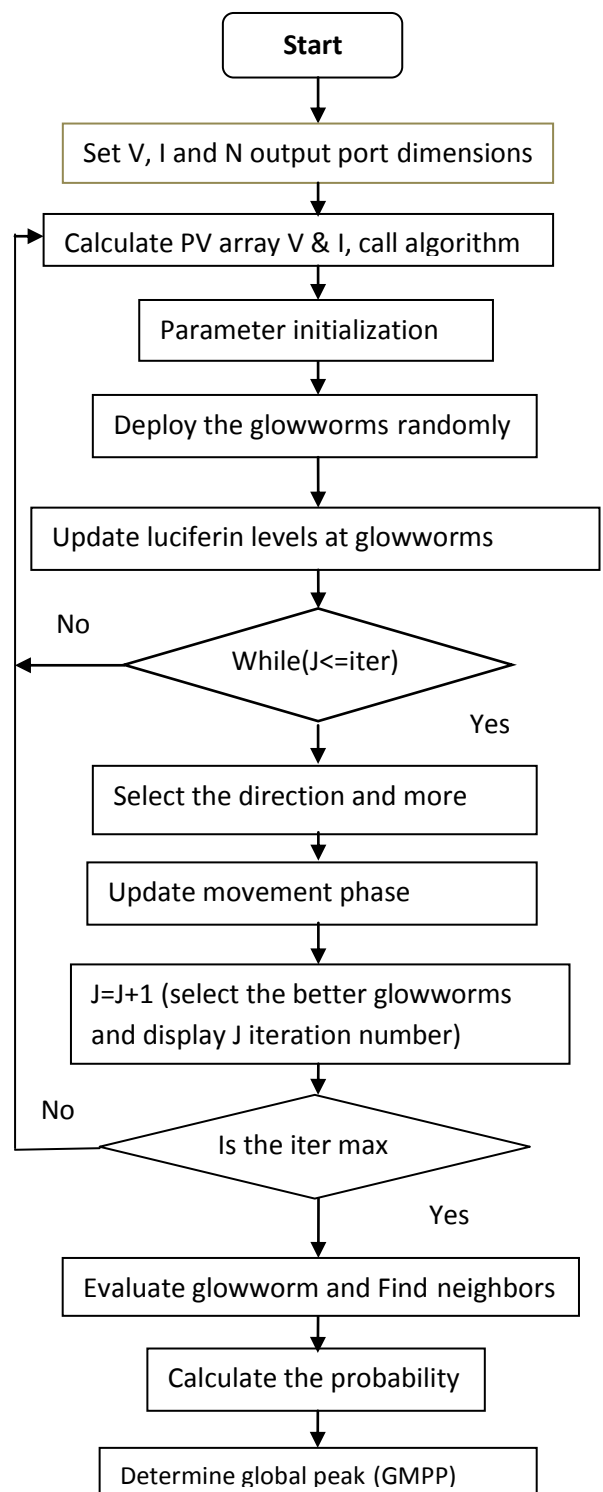
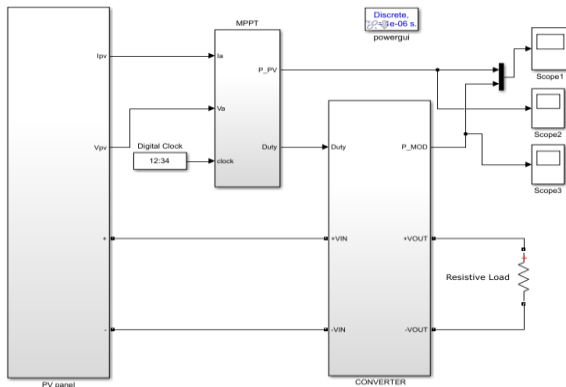


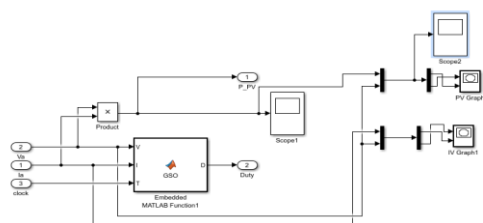
Fig -6: Flowchart of the GSO algorithm

#### 4. Simulation of MPPT Using SIMULINK and Result Discussion

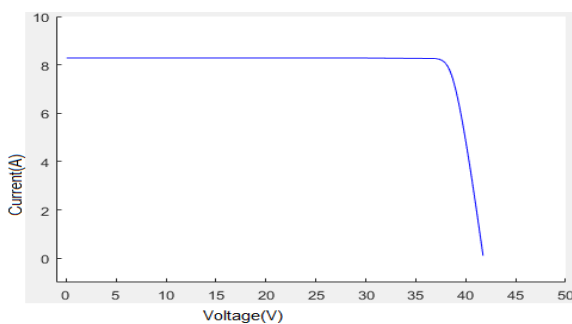


**Fig-7:** PV fed with DC-DC LUO converter using GSO algorithm

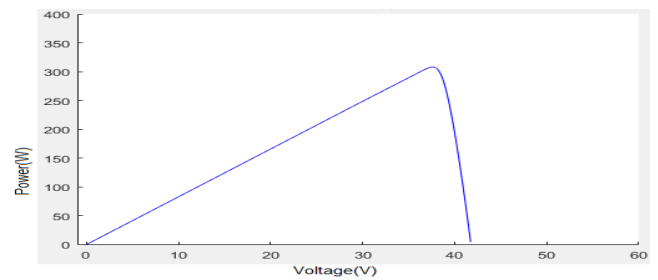
Simulation for MPPT technique is shown in fig.7. In this work, the GSO algorithm is adopted to optimizing the reference voltage of the PV system under uniform and non-uniform irradiances. The LUO converter adjusts the duty cycle of the switch according to the reference voltage. Finally, the output power of the PV system is controlled. The simulation result of the GSO algorithm is compared with that of the traditional PSO algorithm under the constant irradiance. The structure diagram of the system is presented in Fig 10.



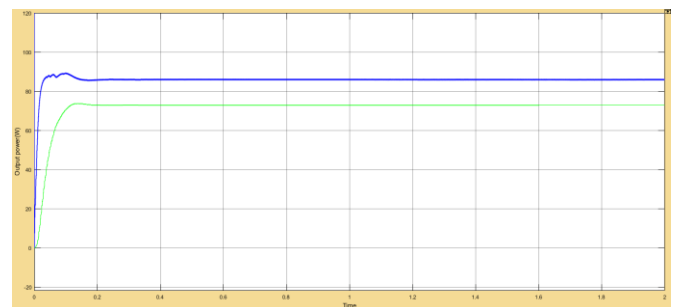
**Fig-7a:** Subsystem of MPPT algorithm



**Fig-8:** I-V characteristic of the PV module under 1000W/m2 irradiances.

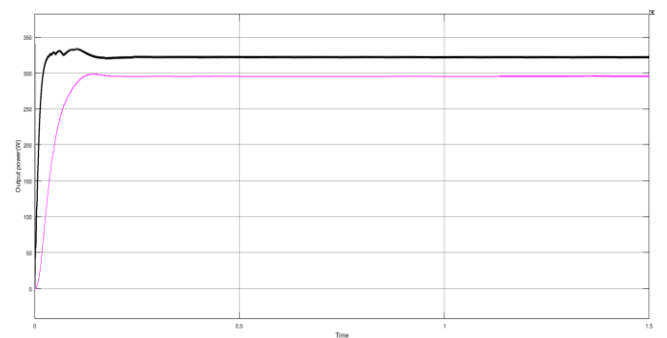


**Fig-9:** P-V characteristic of the PV module under 1000W/m2 irradiances



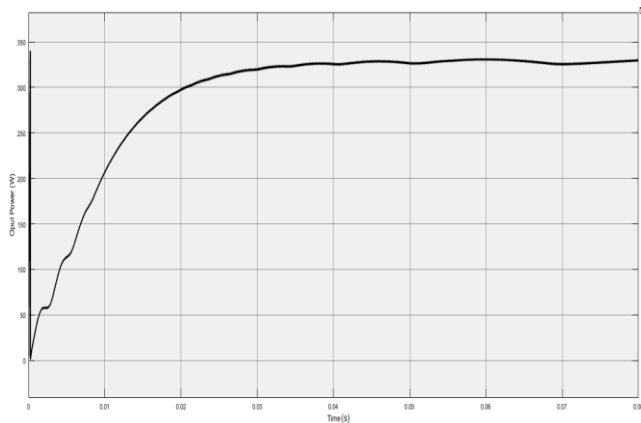
**Fig-10:** Output power of the PV module for the GSO method and PSO method under 250W/m2

Fig.10.illustrates the output power(W) of the Photovoltaic system for the GSO method and conventional method under lower solar irradiance (250W/m2) The simulation result shows that the GSO MPPT algorithm can track the maximum power, Where as the conventional PSO method has low power efficiency and is not capability of converge to the maximum power.



**Fig-11:** Output power of the PV module for the GSO method and PSO method under 1000W/m2

Fig.11 shows the output power of the Photovoltaic module for the GSO method and conventional method at 1000W/m2, The simulation shows that the maximum power tracking efficiency of the proposed GSO algorithm is greater than that of the traditional PSO algorithm. Various tracking effects for PSO could be shown when two step range are used. This work selects a result with low and steady oscillations will be occurred but slowly tracking speed output power.



**Fig-12:** Output power of the PV module for the GSO method under 1000W/m<sup>2</sup>

## 5. Conclusion

The MPPT control method based on the GSO algorithm is implemented. The control mechanism involving optimizes the reference voltage of the PV system using the proposed GSO, adjust the operating voltage through the LUO converter, and finally the system to working at the MPPT. The proposed control method is implemented and verified successfully using MATLAB/SIMULINK. The simulation results indicates that the method can track the constant irradiance and determine the MPPT under changing irradiance. Thus, minimum power loss occurs after connecting with the load. The results of the GSO algorithm are 250W/m<sup>2</sup> & 1000W/m<sup>2</sup> at constant irradiance is compared with those of the conventional PSO algorithm. The tracking maximum power speed and precision of the proposed method is higher than the conventional PSO method, particularly at low irradiance. Hence, the control method based on the GSO algorithm can be utilized for the MPPT of PV systems.

## REFERENCES

- [1] B. Subudhi and R. Pradhan, "A comparative study on maximum power point tracking techniques for photovoltaic power systems", *IEEE Transactions on Sustainable Energy*, vol. 4, no. 1, pp. 89–98, 2013.
- [2] Chakkarapani Manickam, Guru Raghav Raman, Guru Praanesh Raman, Saravana liango Ganesan, "A Hybrid Algorithm for Tracking of GMPP Based on P&O and PSO With Reduced Power Oscillation in String Inverters", *IEEE Trans Ind* vol.63, No.10, October 2016.
- [3] M. A. Elgendy, B. Zahawi, and D. J. Atkinson, "Assessment of perturb and observe MPPT algorithm implementation techniques for PV pumping applications", *IEEE Transactions on Sustainable Energy*, vol. 3, no. 1, pp. 21–33, 2012.
- [4] A. K. Abdelsalam, A. M. Massoud, S. Ahmed, and P. N. Enjeti, "High-performance adaptive Perturb and observe MPPT technique for photovoltaic-based micro grids", *IEEE Transactions on Power Electronics*, vol. 26, no. 4, pp. 1010–1021, 2011.
- [5] T. Eswam and P. L. Chapman, "Comparison of photovoltaic array maximum power point tracking techniques", *IEEE Trans. Energy Convers.*, vol. 22, no. 2, pp. 439–449, Jun. 2007.
- [6] Kirshnanand N. Kaipa, D. Ghose "Glowworm Swarm Optimization Algorithms, and Applications", *vol. 698*, Springer 2017.
- [7] Y. He and F. L. Luo "Analysis of Luo converters with voltage-lift circuit" *IEE Proc.-Electr. Power Appl.*, Vol. 152, No. 5, September 2005.
- [8] H. Renaudineau et al., "A PSO-based global MPPT technique for distributed PV power generation", *IEEE Trans. Ind. Electron.*, vol. 62, no. 2, pp. 1047–1058, Feb. 2015.