

# SOLAR INTEGRATED SMART MIRROR

Ms. Sheenu P<sup>1</sup>, Anasooya Devan A<sup>2</sup>, Benoy David<sup>3</sup>, Gayathri B M<sup>4</sup>, Vishnu J Nair<sup>5</sup>

<sup>1</sup>Assistant professor, Department of EEE, MBCET, Kerala, India

<sup>2,3,4,5</sup>B Tech Students, Department of EEE, MBCET, Kerala, India

\*\*\*

**Abstract** - In this world everyone needs a comfort life. This project is about an intelligent mirror based on Raspberry Pi using IoT and AI. Our proposed system allows the mirrors to receive news online and display it on the mirror screen along with other details such as time, temperature, humidity, location and it can be used to replace a notice board in the colleges/offices. Our system uses a Raspberry Pi based processor board along with display, IoT and AI. We use specialized glass with a back frame to encase the system. For the purpose of creating a green environment we are in co-operating solar panel in to the system. We are adding AI to make it as a user friendly and interactive two-way communication system with the mirror.

efforlessly, they can also be integrated as a thief detection system.

### 3. PROPOSED SYSTEM

This project is about an intelligent mirror based on Raspberry Pi using IoT and AI. To make a mirror more innovative we are adding some of new features. It has widgets for displaying weather condition, time, date, latest news headlines. For the purpose of creating a green environment we are in co-operating solar panel into the system. The smart mirror will also display the important notices of an institution if required.

**Key Words:** Smart Mirror, Raspberry-Pi, IoT, AI, Solar panel, Weather, Time, News, Notice board.

### 1. INTRODUCTION

Smart mirrors are the mirrors of the future. It has widgets for displaying the current weather conditions, time, events, latest news headlines. Basically, the mirror looks like a normal mirror but when someone stand in front of it becomes an innovative product of technology. The Raspberry Pi is programmed and connects to a monitor with inbuilt speaker so as to provide an onscreen interface and voice assistance as well. A common approach for building a Smart Mirror is to use a high quality one way glass, a LCD monitor, a frame to hold the glass and monitor[1]. Whether it is through the television or internet ,people need to be informed and in touch with the current affairs happening around the world[1]. we look at the mirror daily and internet with it psychologically to find out how we look and how our attire is[2].The interactive Mirror is developed from a mirror with proper embedded intelligence for offering features such as weather of city ,latest updates of news and headlines and local time corresponding to location. The many benefits of using a smart mirror is that it make life easier as we need to look at phones every time to check, time, weather, location etc.

### 2. LITERATURE SURVEY

Several methods are used to develop the smart mirror. The most popular is Internet of things .Each idea is nearly same with the minor difference in it. A smart mirror is a system that functions as mirror with additional capability of displaying date, time, current temperature, weather details. Not only do they allow users to see relevant information

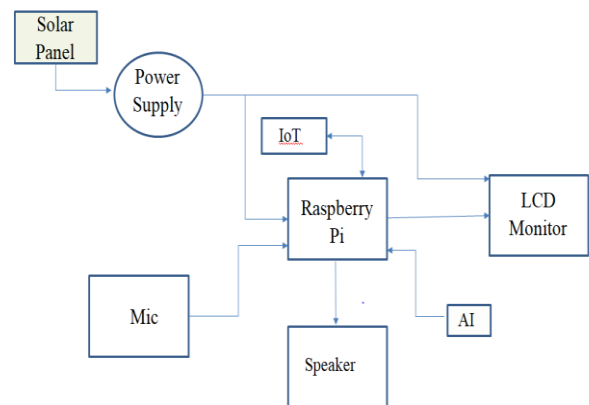

Fig1.Block diagram for Smart mirror

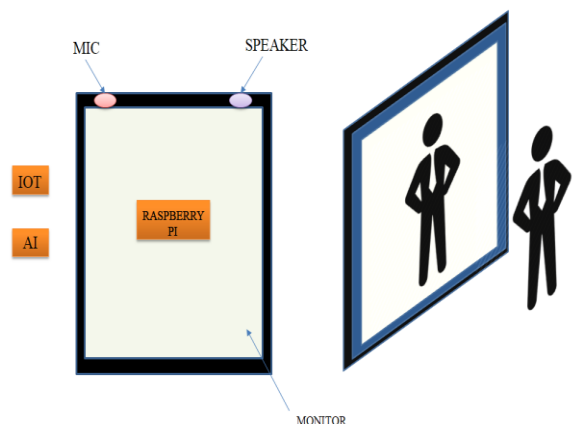

Fig2.Architecture of Smart mirror

The goal of the Smart Mirror is to provide a single easy to access location for a person to receive all the information that could affect how they prepare for the day use of LCD displays and a two way mirror, weather, time and date, and news are available at a glance. Additionally, a user friendly interface, accessible from any Wi-Fi enabled device, allows the user to easily setup the connection to their home Wi-Fi, change the location from which they receive the weather, and select a source from which to receive the day's headlines. By building these features into a mirror, which most people will already be using in their morning routine, it is possible to present this information in such a way that it will seamlessly blend together with the task of morning grooming.

#### 4. IMPLEMENTATION

The Smart Mirror designed in this project will provide the user with an enhanced mirror experience. By making use of multiple displays, the user can stay updated on the time, weather, and news headlines while preparing for the day in with the fully functional Smart Mirror. AI to make it as a user friendly and interactive two-way communication system with the mirror.

##### 4.1 INTERFACING WITH IoT

**TIME**-According to the time zone of a country the particular time will be displayed on the screen

**DATE**-According to the google calendar the particular day, date, month and year will be displayed on the screen

**WEATHER**-We took the weather API Token from Darksky.net which acts as a platform to collect information about the particular weather details of a locality

**NEWS**- We used a google platform known as Google News to collect the current news of our country

**DISPLAY**-We are also displaying greetings accordingly to time of the day and common messages

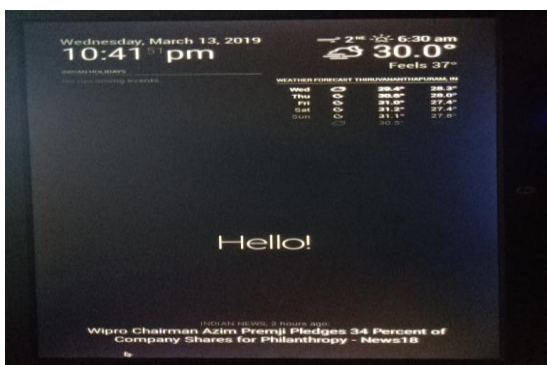

Fig3. Interfacing with IoT

##### 4.2 INTERFACING WITH MIC AND SPEAKER

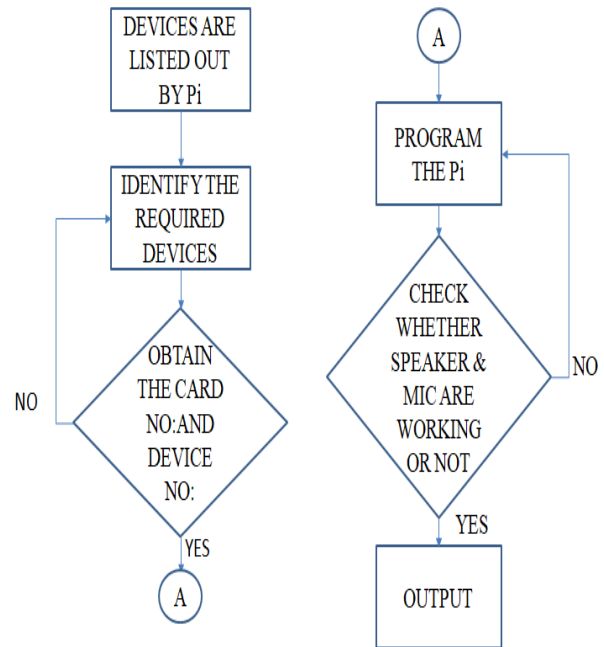

Fig4. Flowchart of Mic and Speaker interfacing

##### 4.3 INTERFACING WITH NOTICE CALENDAR

The information in the Google Calendar is in sync with the Smart Mirror. Any change that is made in the Google Calendar will in default make those changes in the Smart Mirror. For the purpose of college, we have integrated the college calendar into our system such that the important upcoming events dates will be displayed in our mirror.

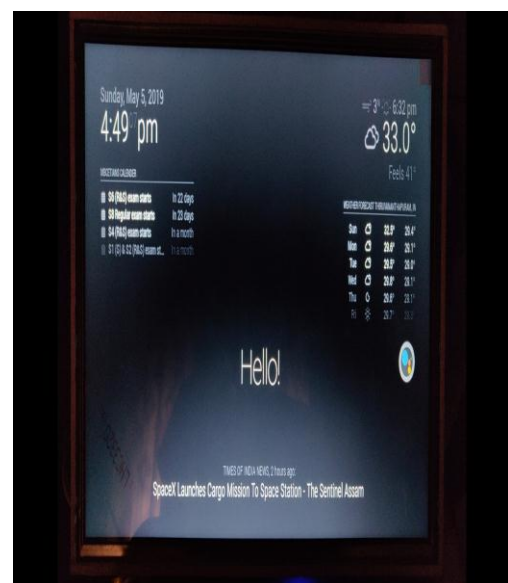

Fig 5. Interfacing with Notice Calendar

#### 4.4 INTERFACING WITH ARTIFICIAL INTELLIGENCE

Google Assistant is an artificial intelligence-powered virtual assistant developed by Google. It can engage in two-way conversations. Google Cloud Platform can be used to enable the Google Assistant. In order to access the Google Assistant we need credentials. Natural-language understanding or natural-language interpretation is a subtopic of natural-language processing in artificial intelligence that deals with machine reading comprehension. Natural-language generation (NLG) is one of the tasks of natural language processing that focuses on generating natural language from structured data.

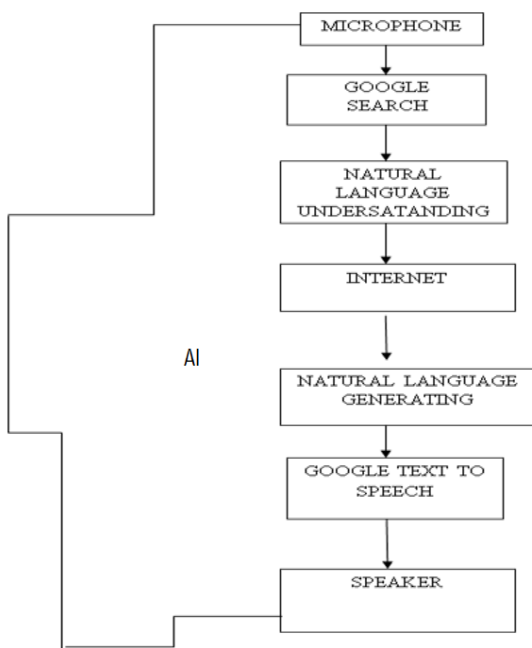

Fig6. Flow chart of Artificial Intelligence

#### 4.5 INTEGRATING WITH SOLAR SYSTEM

Here we are using a 100W solar panel. There is a solar charge controller for regulating the output voltage or current from the solar panel, which is then connected to the battery. We are using a 12V, 7Ah solar battery. From the solar charge controller the connection to the load is taken.

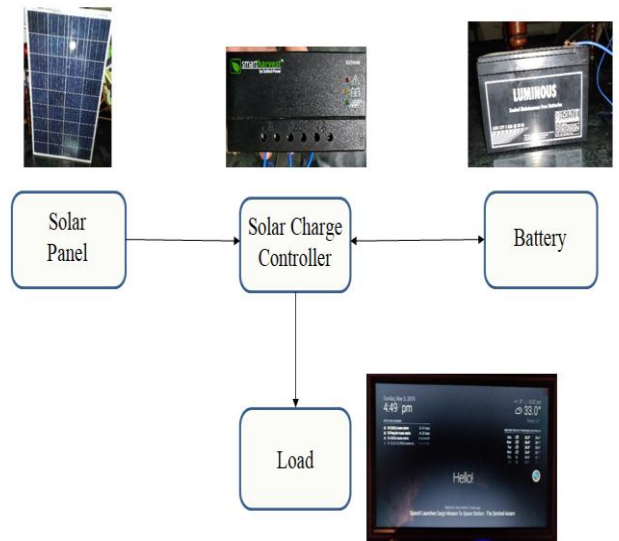

Fig7. Integrating with Solar system

#### 4.6 HARDWARE SETUP

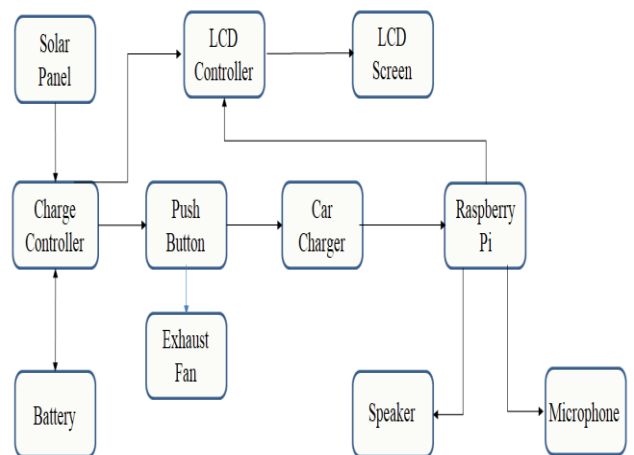

Fig8. Hardware Setup

#### 5. CONCLUSIONS

The smart mirror is a system which gives user information such as date, time, temperature, weather prediction for the coming days. This two way communicating mirror system is solar powered in order to provide a green environment campus. Our notice calendar is also integrated into our system. For future expansion we can integrate home

automation system, touch controlled system or gesture controlled system.

## REFERENCES

[1] Prof. Jagdish A. Pateljayshri T. Sadgir Sonal D. Sangaleharshada A. Dokhale ,“ A Review Paper Design and Development of a Smart Mirror Using Raspberry Pi ” , *International Journal of Engineering Science Invention (IJESI)* , Volume 7, Issue 4 ,PP 40-43, April 2018.

[2] Lakshmi N M, Chandana M S , “IoT based Smart Mirror using Raspberry Pi” , *International Journal of Engineering Research & Technology (IJERT)*, volume 6 , issue 13 ,January 2018.