

# Analytical Study on Bolted Endplate Connection with Different Bolt Materials and Bolt Arrangements.

Sony Sabu<sup>1</sup>, Jobin Johnson<sup>2</sup>

<sup>1</sup>Mtech Student, Computer Aided Structural Engineering, ICET, Mulavoor P.O  
Muvattupuzha, Kerala, India

<sup>2</sup>Assistant Professor, Civil Department, ICET, Mulavoor P.O, Muvattupuzha, Kerala, India

\*\*\*

**Abstract** – From ancient times many different construction materials were used in the construction of buildings. But the most widely used materials are concrete and steel. Unlike concrete the steel structures are more tensile in nature with high strength per unit mass which allow steel sections to be small and lightweight compared to other materials. Due to the mode of construction, the design of steel beam column joint is important in every construction. It can be either bolted or welded connections. When using bolted connections, the performance of the connections affected by the material properties and the arrangements of the bolted connection. In this study a cantilever steel beam column joint is undergone an analytical study to understand the performance of the models under different load cases (Under Rotation and Displacement). The results then analysed to understand the performance of different models under different loads and that results used to understand the influence of bolt materials and its arrangements on the performance of the steel beam column joint.

**Key Words:** Bolted Connection, NiTi alloy, Bolt arrangements, Force deformation relation, Moment-Rotation hysteresis curve.

## 1. INTRODUCTION

### 1.1 General Background

Recent increases in the construction of buildings with steel skeleton and brick filling like in the cases of supermarkets and large showrooms indicates that these type of steel constructions are much faster and easy to combine InSite than concrete structures and also this type of structures are easy to disassemble due to the usage of bolted connections. So, it is evident that the need for these type of steel structures is on the rise and as in every case of products, its important to study and experiment different aspects of the steel structure to improve its performance and life. The Basic ways to join the steel beam column is by either field welding or using a bolted end plate connection. Due to different advantages like ductility and distribution of stress, the bolted connections are preferred over welded connections in most cases. There are several codes and regulations that prefer different type of bolted connection and stiffener usage.

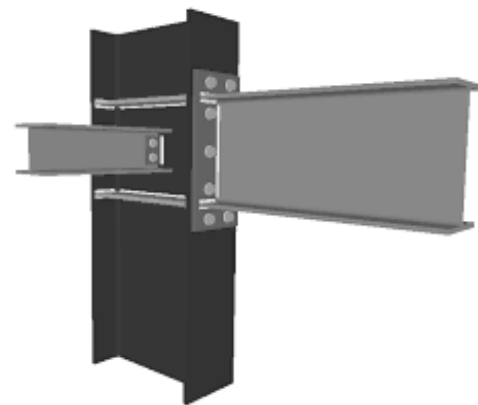

Fig -1: Bolted beam column joints

The studies on the beam column joint of steel structures are numerous but the diversity in the area of bolt materials and arrangement is smaller. From previous studies like in the reference (2) and (6) the changes in the bolt materials changes the performance of the connection so further studies in this particular case is required. In this study the focus is mainly on the performance of the steel beam column joint under rotational and linear displacement conditions and the comparison of force reaction along with force vs displacement performance to arrive at an understanding of the performance of the steel beam column joint with the influence of the above-mentioned conditions

## 2. NUMERICAL INVESTIGATION

### 2.1 Base Model

In this Project the Steel beam column joint is modelled using ANSYS software which one of the widely using FE software for analytical studies like this one. Two sets of Three models were developed with the dimensions of the steel beam, column, stiffener, endplate and bolts being the same while each model have 4 different bolt arrangements and the second set of these models have different bolt material instead of structural steel which used in the first set of models. The dimensions of the models used column size 325 x 375mm with 3000 mm length, the beam have a size of 220 x 390 mm and have a length of 1300 mm, the endplate have a size of 260 x 690 mm and the material properties of the

structural steel and pure NiTi alloy used are given in the tables 2 and 3.

**Table -1:** Material Properties of Steel.

Young's modulus of Steel (Gpa)	206
Poisson's ratio of Steel ( $\nu$ )	0.3
Density of Steel, (kg/m <sup>3</sup> )	7850
Yield Stress ( Mpa )	458
Coefficient of thermal expansion ( C <sup>-1</sup> )	1.2 x 10 <sup>-5</sup>

**Table -1:** Material Properties of NiTi alloy.

Poisson's ratio of Steel ( $\nu$ )	0.3
Density of Steel, (kg/m <sup>3</sup> )	6450
Yield Strength ( Mpa )	560

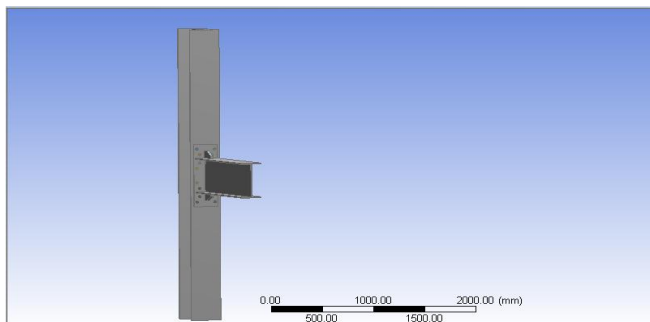

**Fig -2:** Modelled view of Steel beam column joint.

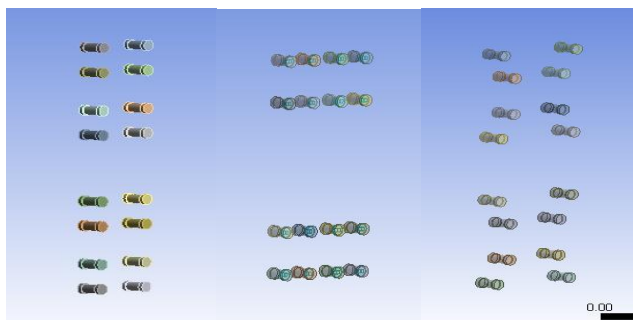

**Fig -3:** Bolt arrangements of Steel beam column joint.

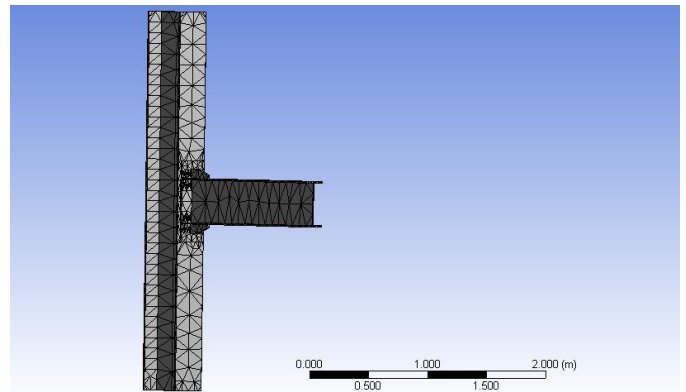

**Fig -4:** Meshing of Steel beam column joint.

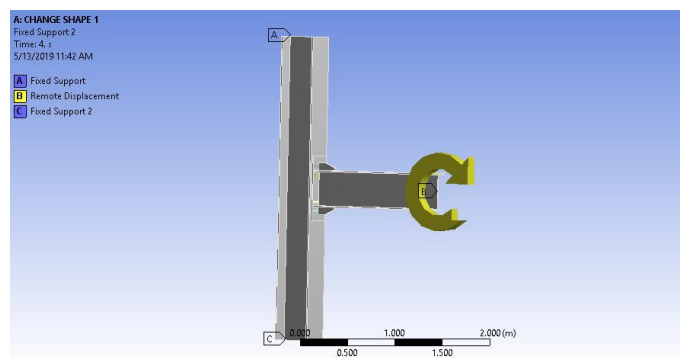

**Fig -5:** Boundary conditions of Steel beam column joint for first load case

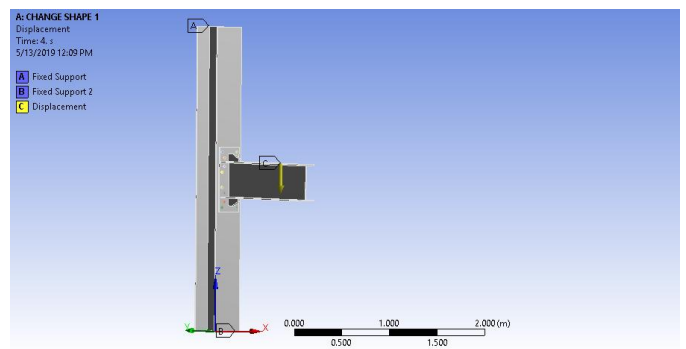

**Fig -6:** Boundary conditions of Steel beam column joint for second load case

Using the software, the models were developed as shown in fig. 1 and fig. 2 and mesh is applied using default mesh as shown in fig.3 and the boundary conditions were applied as shown in fig. 4. After the modelling the model is solved for applied conditions and the results are collected for study. The collected results are mainly force deformation relation from the displacement condition and rotation-moment response and force reactions from the first load cases.

### 3. EXPERIMENT RESULTS AND DISCUSSIONS

#### 3.1 Hysteretic behavior

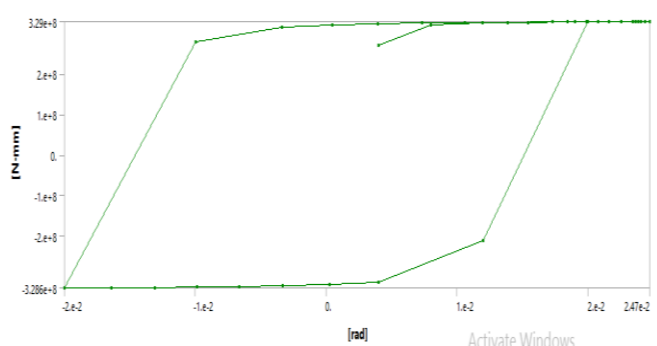

Chart -1: Hysteresis curve for model no. 1 with steel bolts

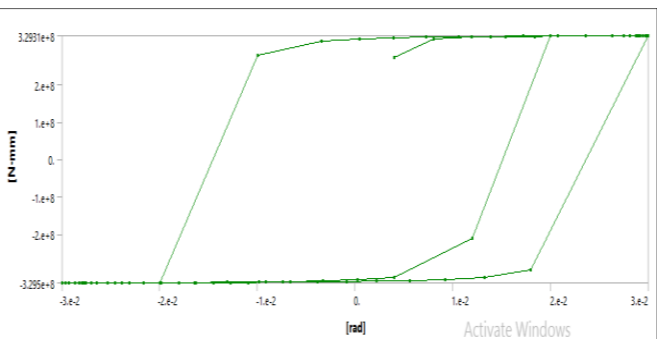

Chart -2: Hysteresis curve for model no. 1 with NiTi alloy bolts

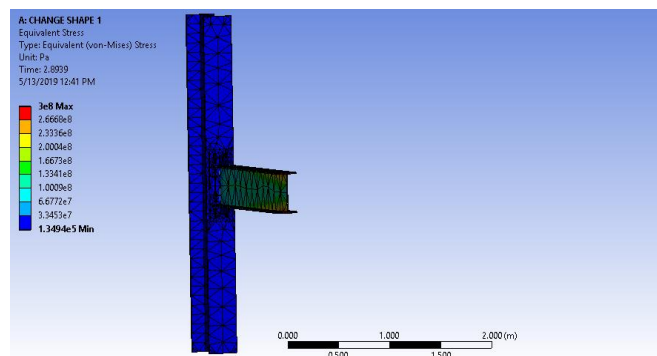

Fig -7: Equivalent stress of model no.1.

From the analysis the analytical moment-rotation hysteresis curve is obtained (as shown in chart 1 and chart 2) and these curves shows that the same set of models with different bolt materials have almost similar shape for the curve but the moments developed under corresponding rotations vary and when comparing all the models the moments developed in the NiTi bolted models are higher compared to the moments developed in the models with steel bolts and the highest value obtained by model no.3 with irregular bolt arrangement. The other parameters like equivalent stress (as shown in fig 6) and strain values are also considered and

its seen that these values for the NiTi bolts are lower than Steel bolts counterparts

#### 3.2 Load Deflection Analysis

The second set of analysis done on all the previous models and the force-displacement relation is obtained as shown in the chart 3. As we can see from the chart that the Model no. 1 with NiTi alloy bolt have higher load capacity and higher displacement before failure. Which closely followed by the model no.3 and model no.2 have lowest yield strength under lowest value of displacement Its important to understand that the ductile performance also affects the performance of the bolted connection under dynamic loading conditions and it's important to design the bolted connections according to that.

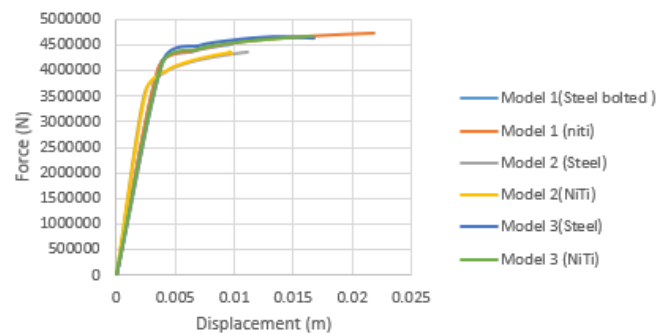

Chart -3: Load-Deflection graph.

### 4. CONCLUSIONS

Based on the conducted study its evident that the changes in the bolt arrangements and the bolt materials do affect the performance of the Steel beam column joint under tested load cases and based on the studied models the following conclusions are obtained:

- Due to High yield strength and other properties the elastic performance of the NiTi bolts are better than steel bolts under loads.
- The moments developed at 0.2 rad rotation is high for NiTi bolts compared to Steel bolts.
- Model no.2 and Model no.3 with NiTi bolts shows higher strength compared to model no.1 with maximum force developed  $2.52 \times 10^5$  and  $2.565 \times 10^5$  N respectively under first load cases
- Base model (model no. 1) have lower performance compared to Models with modified bolt pattern
- Irregular bolt arrangement with NiTi bolts (Model no.3) provides better results than linear bolt arrangements.

## REFERENCES

- [1] Concepcion Diaz, Marino Victoria, Pascual Marti, Osvaldo Querin (2018). "FE model of beam- to-column extended end-plate joints". Elsevier
- [2] Nader Fanale, Morteza. (2016) "Cyclic behaviour of extended end-plate connections with shape memory alloy bolts".
- [3] Roberto Tartaglia, Mario D'Aniello, Raffaele Landolfo, (2018) "The influence of rib stiffeners on the response of EEP joints". Elsevier
- [4] Jia Wang, Brian Uy,Huu-Tai Thai, Dongxu Li, (2018)." Behaviour and design of demountable beam-to-column composite bolted joints with extended end-plates". Elsevier
- [5] Antonella B. Francavilla, Massimo Latour, Vincenzo Piluso, Gianvittorio Rizzano, (2018) "Design of full strength full-ductility extended end-plate beam-to-column joints". Elsevier
- [6] Machel Morrison, Shahriar Quayyum, Tasnim Hassan.(2017)"Performance enhancement of eight bolt extended end-plate moment connections under simulated seismic loading". Elsevier