

Improving the Performance of All Terrain Vehicle

Sanket Indalkar¹, Sushant Randive², Nayan Sarode³, Prof. Y.A. Yewalikar⁴

Dept. of Mechanical Engineering,
P.E.S. Modern College of Engineering, Pune

Abstract: The project goal is to design and build a single-seat, all-terrain, sporting vehicle whose structure contains the driver. The vehicle is to be a prototype for a reliable, maintainable, ergonomic and economic production vehicle which serves a recreational user market. The vehicle should aspire to market-leading performance in terms of speed, handling, ride, and ruggedness over rough terrain and off-road conditions. This special kind of four-wheeled vehicle used for recreational and exploration purposes. The project focuses towards explaining the procedure & methodology used for designing an off-road vehicle. It is been seen in designing phase that the best optimized design is done for improving the performance and weight reduction as well as considering parameters for reducing the cost.

Key Words: durability, Commercialization Ergonomics, Finite Element Analysis, Safety, Capacity, Improve, Manufacture, Effort

1. INTRODUCTION

The goal in project is to design, build and race off-road vehicles that can withstand the harshest elements of rough terrain. A preliminary design was first prepared keeping in mind the guidelines issued by SAE. Indian standards for driver space have been incorporated and a PVC mock-up was developed to evaluate the driver ergonomics. A proper suspension type was then selected and designed as per the requirements of the vehicle. The CAD modelling of the frame and other components was done. This design was checked by Finite Element Analysis after estimating the load and the weight of the frame optimized. A rollover analysis was then carried out to ensure safety in such a situation. The Rollover

Analysis involved evaluating static stability and ensuring compliance with the pertinent Indian Standards. Hence, after ensuring safety, the design was finalized

2. PROBLEM DEFINITION

To design, manufacture and commercialize a multipurpose all-terrain vehicle that caters the modern diverse applications viz military, agricultural and many more. The design should be feasible in following parameters-

1. Design for manufacturing and Assembly:

DFMA is the combination of two methodologies; Design for Manufacture, which means the design for ease of manufacture of the parts that will form a product, and Design for Assembly, which means the design of the product for ease of assembly

2. Safety and Ergonomics:

A disheartening reality for many safety and ergonomics professionals is that many of their initiatives ultimately become the victims of their own success. Once they accomplish the organization's initial objectives, investments in ergonomics and other safety solutions either evaporate or are reallocated elsewhere.

3. Commercialization:

Commercialization is the process that converts ideas, research, or prototypes into viable products and production systems that retain the desired functionality, while designing them to be readily manufacturable at low cost and launched or implemented quickly with quality designed in. Commercialization also involves formulating effective manufacturing and supply chain strategies early, devising

implementation strategies, and implementing those strategies. Commercialization may be a necessary step for commercial success for innovations coming from start-up.

3. SCOPE

The main scopes of the project are:

1. Agricultural applications:

ATVs can be used to inspect crops and livestock, to fertilize and apply chemicals, to inspect and repair irrigation systems and fence lines, to supervise field crews, to herd livestock, to mark timber, to mow grass, to move dirt and to transport things from here to there and back again.

2. Military applications:

The ATV Military vehicles are the solution for easy movement of military personnel in tough off-road terrains like hills, forest, snow, water, marshy land, desert, rocky land etc. Built to match the tough working of the Defence and Police, reaching the unreachable, achieving the impossible has become easily attainable with the range of Polaris Vehicles. Polaris "Light Tactical Vehicles" are most suitable for anti-insurgency, anti-terrorist & anti-naxal operations for quick movement in guerrilla war operations.

3. Rescue applications & Forest applications:

The off road vehicle deliver the hardest working performance and rugged capability your vehicle needs to quickly and effectively respond to both emergency and controlled situation in harsh terrain and environment.

4. Other Applications:

Surveillance in unmanned area, enhancing the driver safety, offering new sense of freedom for physically challenged people, The Go-anywhere vehicle

4. MATHEMATICAL WORK

4.1.0 CHASSIS:

Chassis is called as the skeleton of a vehicle; besides incorporating other sub-systems of the vehicle it should also

provide driver safety. The other subsystems are integrated on chassis so to achieve this, chassis should be rigid, for it to withstand different stresses & shocks. The roll cage is designed in way that all the forces induced should not concentrate at any single node. The main goals of chassis are:

- Ergonomically safe
- Light weight & Durable
- Simple to manufacture

4.1.1 Design Approach:

We have designed the roll cage keeping in view the safety & ergonomics. Material selection of the chassis plays a crucial part in providing the desired strength, endurance, safety & reliability of the vehicle. The strategy behind designing of the roll cage was to achieve maximum strength for the pipes, good bending stiffness, minimum weight & maximum weld area. Evaluation of cost, availability, & properties was done and AISI 4130 was finalized considering the above strategy.



Fig.1 Prototype

4.1.2 Driver Ergonomics

We given emphasis towards the driver safety by ensuring that the driver is seated in an ergonomically sound way without compromising his/her safety under any circumstances and simultaneously following the rules. The placement of pedals, steering column and steering wheel was done considering driver safety without violating rules. The position of the kill switch was decided such that it is

easily accessed under emergencies without accidentally switching off the engine.

A comfortable driver posture was also considered. An ergonomically suitable position for a 95 percentile male was taken into consideration and accordingly the roll cage was designed. The angle at the elbows was taken as 1100 for effective steering without any strain at the shoulders. Pedals were also positioned such that the driver is easily able to use them in all conditions.

4.2.0 SUSPENSION

The unpredictable nature of off-road racing creates the need for a reliable & efficient suspension system. The suspension system is tuned according to the actual needs, keeping in mind the manufacturing aspects & the nature of loading it will have to suffer. The design goals of the suspension system were:

- To prevent the road shocks from being transmitted to the vehicle components
- To preserve the stability of the vehicle in pitching or rolling, while in motion
- Improve durability of components

4.2.1 Design Approach

The fully independent and long travel suspension is implemented which allows each wheel to react separately with right comfort and traction. Double wishbone type suspension is designed to provide long arc travel. After global market survey, FOX FLOAT 3 and FOX FLOAT 3 EVOL air shocks were selected for their high performance shock absorbing capacity and higher reactivity which use air as spring.

In acknowledgement of the tendency for FEA to provide useless or false results, a myriad of loading conditions and hand calculations were used to verify component performance under varying stresses and strains. Complex combined loading scenarios were designed to challenge component performance under the most strenuous conditions. Rigorous testing of 500 km is

done on all the above components which ensure its sustaining capacity throughout the event.

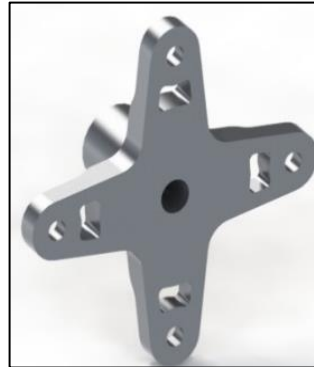

Fig.2a Old Hub Design



Fig.2.b New Hub Design With Insert

4.3.0 STEERING

Steering system of a car is of the utmost importance as it has to have a good reaction to all turns and corners at any kind of terrain. The steering system should be such that the driver can easily manure the vehicle and the actually follow the desired path. The design goals of the steering system are:

- To provide directional stability
- To achieve quick and easy maneuverability
- To provide perfect rolling motion of the road wheels at all times

4.3.1 Design Approach

The steering system should be responsive enough at high speed as well as at low speed turns and also possess some self-returning action. The parallel steering geometry was chosen over the others as it works in such way that at higher speed anti-Ackermann condition is achieved and at lower speed Ackermann is enacted, thus ensuring optimum steering is achieved.



Fig.3 Steering Assembly

This design was achieved by studying previous THE tracks. By taking into account the mounting, simplicity in design and compactness of the vehicle; rack and pinion was chosen over others. Keeping scrub radius of -6mm gives a jacking effect at front wheel. Due to the difference in front and rear track widths, an over-steering effect is induced which would reduce the turning radius to around 2 meters.

4.4.0 BRAKES

An excellent braking system is the most important safety feature of any vehicle. It needs to be fail proof, robust and needs to work efficiently and flawlessly in any condition. The main aspects for the braking system are:

- All wheel lock must be achieved.
- Minimum braking distance.
- Light in weight & efficient.

4.4.1 Design Approach

We designed our system as per vehicle's weight; driver's effort and vehicles specifications like rim off-set, CG height, wheel base etc. To achieve the above design aspects, design was initiated by determining the required bore diameter of the TMC through calculations and after market survey Tata 407(Turbo) TMC was selected as its bore diameter satisfied our calculations.

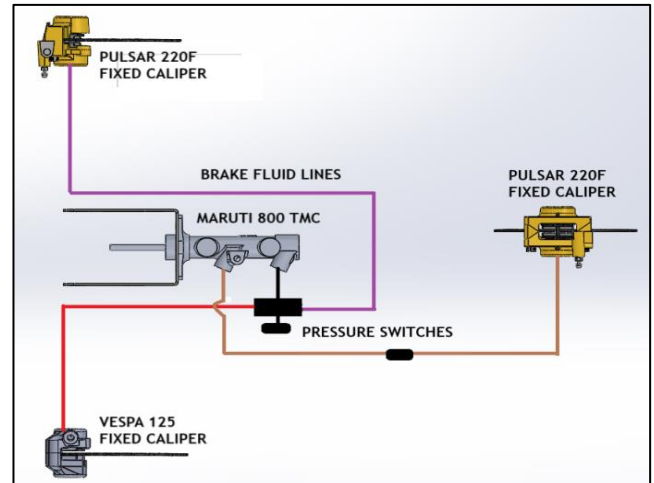

Fig.4 F/R Split Braking Circuit

We decided to use fixed type calipers due to their rigidity, compactness, and more clamping force. Pulsar 220F and Vespa 125 both fixed type calipers were preferred as they were readily available and matched our requirements. For the testing of the system, we performed brake test as per the event's requirements including all wheel lock at 45 kmph. We measured the stopping distance and checked if it is in the limit. Also checked discs and callipers mounting for alignment.

While braking, due to dynamic weight transfer most of the weight is transferred towards the front of the vehicle and hence there is less braking force is needed at the rear. Inboard braking with a single disc is used at the rear since spool type gearbox is used. After material studies, C45 is used for front disc with 160 mm diameter. The disc was manufactured by laser cutting and surface finishing. OEM 200mm disc at the rear is used as it was easily available and met our requirements. For light weight of the vehicle we chose the steel braided hoses and clamped the end joints to the hoses for minimum leakage of the brake oil. Rear disc is mounted on the output shaft of the gearbox using a hub by machining using VMC. Laser cut pedals are manufactured from mild steel material.

4.5.0 POWER TRAIN

The challenge of designing an efficient drive train system requires careful consideration of simple

mathematics to optimize the delivery of the power produced by the engine to the wheels at an appropriate torque and rpm. The main aspects for the braking system are:

- To achieve optimum gear ratio
- To utilize maximum power from engine
- To ensure operation of power train within peak engine values using CVT.

4.5.1 Design Approach

Considering dynamic weight transfer and tyre dimensions vehicle dynamics were studied and accordingly overall reduction is calculated. According to market survey, Gaged CVT is selected considering high & low ratios, cost, availability and weight. After studying previous tracks and THE vehicles, a speed of 52km/hr was found to be optimum. A number of iterations of gear ratios are done to achieve optimum acceleration to counter all the hurdles during the event. 20MnCr5

Gearbox casing was manufactured by Vertical Milling Machine and jig boring is done for accurate tolerances. Gear hobbing and lathe machines are used for gear manufacturing. The gears are hardened up to 50HRC (according to the standards). By studying the market, a number of iterations were done for half shaft plunge and articulation for the required jounce and bounce conditions. Tata Nano Tripod joint is selected for the gearbox side and Hyundai Santro Rzeppa joint was selected for the wheel end side is selected as gear material after following standard design procedures

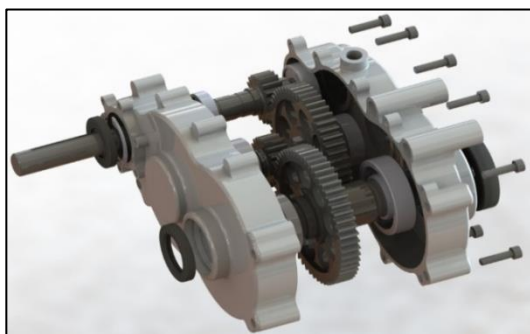

Fig.5 Gearbox

For the calculated C-C distance, addendum diameters, bearing forces and braking torque, a gearbox casing is designed for 4.5 mm thickness using aluminum 6061-T6 material. CAE for the same is done in which stresses induced are less than the yield strength of the material.

5.0 FINITE ELEMENT ANALYSIS

While designing a component, various parameters are taken into consideration and the design is done in CAD. Post designing the component needs to be verified such that it will sustain the loading conditions encountered during its complete performance. The results are compared with the material properties and its ultimate effect on the integrated components. Having a satisfactory result will push the component towards the fabrication and implementation of the idea.

5.1 Roll Cage:

After completing the design of the Roll Cage, Finite Element Analysis (FEA) is performed using ANSYS 16.0 to ensure expected stresses do not exceed material properties. We did static and dynamic analysis of the roll cage. Number of iterations are performed in ANSYS by considering different loading conditions like Explicit Dynamics, Front impact, Side impact, Rear impact, Offset impact, Roll over and Torsional. Preliminary analysis show that the roll cage is not safe for side impact and front impact. Design changes are made such that by adding a few members the force distribution was evenly spread. From the results of analysis, we conclude that Von Mises stresses are within the limits and FOS is greater than 2. This ensure the driver is not a risk and it is safe to proceed for manufacturing.

5.2 Uprights:

For 3D analysis, the loading conditions are determined by the simulations on Lotus. At first, we performed iterations for different materials and thickness,

from which a conclusion is made that Aluminum 7075-T6 satisfies the required conditions. For front knuckle, forces like braking torque, cornering forces, weight, steering forces, bump forces etc. are considered. Bearing in mind the force flow line through the pivot points (Control Arms), reactions from the spindle and for sudden bump conditions analysis is done such that the knuckle resist the tendency to deform or break. By using H-Arm for the rear, it was necessary that the pivot points on the knuckle should sustain the toe change during operation. The analysis showed that the knuckle is more reliable due to absence of brake assembly on it. The suspension components are critical as the forces are transmitted through them, we meshed the component with mesh size=3mm and focusing on the force flow lines and connectivity; we observed that in these aluminum components stresses concentrate on the mating surfaces for which appropriate bolt tightening and uniform pressure are necessary.

5.3 Component mountings on chassis:

Basic Free Body Diagram of the integrated component is considered and 2-D analysis is performed. Mountings should bear weights, impact forces, unaccepted forces and transmitting forces from its particular component. For mountings it is important that it should not deform under the forces it needs to transmit. Suspension pickup analysis for the first iteration showed that the stresses induced are very less. Hence, optimization is done and the changes showed that the design is safe. On analyzing all the mountings of chassis using topology optimization method and transient analysis method, weight is reduced.

5.4 Control Arms:

The vehicles weight distribution is 40% in the front and 60% in the rear. The use of the pneumatic suspension allow to easily adjust the spring rate of the shocks at any time by adding or extracting air. The spring rate of the shocks is equivalent to 76.54 lbs/in for the front

and 153.56 lbs/in for the rear is considered for calculations and analysis. Iterations are done for various thicknesses for various conditions using simulations on Lotus software. Considering the suspension forces, un-sprung mass, reaction and torsional forces 2-D analysis is conducted for jounce, bounce and cornering situations.

5.5 Gearbox:

Due to the use of CVT, the forces on the input shaft of the gearbox are high as optimum power needs to be transmitted. The tooth form of the gears is modified in KISSsoft software for smoother meshing and higher load carrying capacity. Gear blanking is done to reduce the weight and increase in performance of the gears. Shaft calculations are done in ANSYS software for precise values. As we are using inboard braking for the rear, the gearbox casing is induced with gear and brake assembly weight, braking torque and bearing reactions. Analysis of the whole system is done using a Mesh size = 3mm, it was seen that the stresses on the bearing seats were high. To reduce deformation and avoid failure, ribs are provided to distribute these stresses evenly.

5.6 Pedal:

Since the pedals connect the driver to the engine and brakes, these should be strong enough to create a sense of confidence in the driver. For the brake pedal, a force of 196N is considered for the analysis. A number of iterations are done and the stresses induced show that the brake pedal assembly was strong enough to resist deformation and provide precise actuation for its operation. For the throttle pedal, a force of 98N was used. Results from the first analysis showed that the stresses induced were concentrated. Further optimization is done by providing triangulation to reduce its weight and ensure stress distribution is even thorough out the pedal.

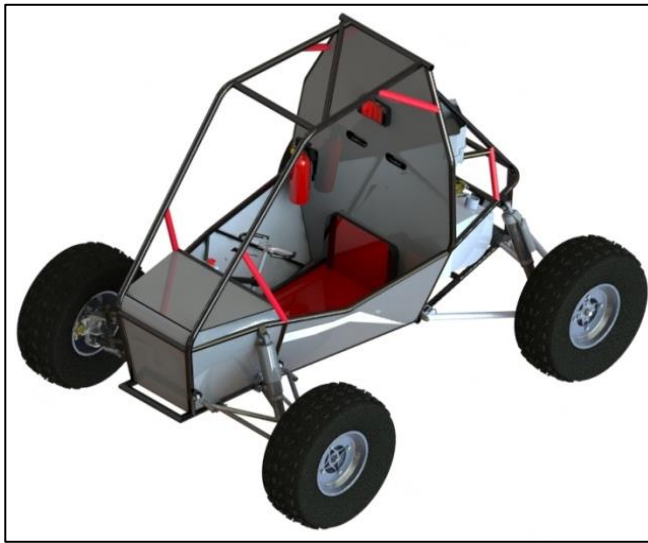

Fig.6 Isometric View of Final CAD

<https://nptel.ac.in/courses/107103012/module1/lec1.pdf>

[6] 'Design of Machine Elements' V. B. Bhandari McGraw Hill Education India Private Limited; Fourth edition (1 July 2017)

6. CONCLUSION

The main objective of this project was to design and manufacture the all terrain vehicle by using design for manufacturing and design for assembly processes, also doing optimization by analysis. It is been seen in designing phase that the best optimized design is done for improving the performance and reduction in weight as well as considering parameters for reducing the cost.

7. REFREANCES

- [1] "Suspension (vehicle)." Wikipedia. Wikimedia Foundation, n.d.Web.8Dec.2016.
[https://en.wikipedia.org/wiki/Suspension_\(vehicle\)](https://en.wikipedia.org/wiki/Suspension_(vehicle))
- [2] Harris, William. "How Car Suspensions Work." HowStuffWorks. N.p., 11 May 2005. Web. 18 Apr. 2017.
<https://auto.howstuffworks.com/car-suspension4.htm>
- [3] Milliken, William F., and Douglas L. Milliken. Race Car Vehicle Dynamics. Warrendale, PA, U.S.A.: SAE International, 1995. Print 3. Smith, Carroll. Tune to Win. Fallbrook, CA:
- [4] ' Disc Brake' Wikipedia. Wikimedia Foundation,
https://en.wikipedia.org/wiki/Disc_brake
- [5] 'Design for manufacturing and assembly' NPTL