

# K- Band Differential LNA using GaN HEMT

Poornima Baliga M<sup>1</sup>

<sup>1</sup>Assistant Professor, Dept. of Electronics and Communication, BMS Evening College of Engineering, Bangalore, INDIA

**Abstract** - HEMT operation has been verified using several materials, especially AlGaAs/GaAs and AlGaN/GaN. A novel design of an Differential LNA is proposed which is operating at the frequency of 21.87GHz, K-band range. Current design of LNA are analyzed, implemented and simulated in Cadence Virtuoso tool. The different gain parameters are analyzed which states the better performance of the design.

**Key Words:** Differential LNA, K-band, HEMT, AlGaN/GaN, Gain.

## 1. INTRODUCTION

Tremendous growth has been experienced by the wireless communication Industry and there is a need for low-cost, high performance wireless front-end circuits. Hence, extensive research has been carried out on CMOS radio-frequency (RF) front-end circuits. [1]. The rapid advancements in the techniques available for RF CMOS circuit design coupled with CMOS scaling have made it possible to integrate all the elements of a transmitter-receiver on a single chip. [2]

An RF power Amplifier (LNA) forms the front end of any radio receiver. It plays an important role for signal amplification in communication systems. [3] It acts as the first stage of a receiver. Its performance greatly affects the overall receiver performance. The main function of an LNA is to introduce minimal noise and at the same time, provide enough gain to overcome the noise of the subsequent stages. [4] The RF stage provides several advantages such as increased sensitivity, increased selectivity, improved AVC (Automatic Volume Control) action and elimination of image-frequency response - peculiar to super heterodyne receivers. [5]

RF power amplifiers can be used in driving high power sources. They can also be used to drive a transmitting antenna, where the transmitter-receivers are used for voice and data communications as well as for weather sensing. RF amplifiers are a crucial factor in communications and it is very necessary for the RF amplifier design to be reliable, efficient, and compact. In personal mobile communication applications, next generation cell phones require wider bandwidth and improved efficiency. The development of satellite communication and TV broadcasting requires amplifiers operating at higher frequencies and higher power to reduce the antenna size of terminal users. The same requirements hold for broadband wireless internet

connections because of the ever-increasing need for speed or data transmission rate. Owing to these needs, there has been significant investment in the development of high-performance devices [6].

This paper is arranged as follows in section II, HEMT device have been discussed. In section III, Analysis, design and implementation of the proposed Differential LNA along with the results are discussed in section IV. Finally, the Results and Conclusion along with the references are discussed in the section V and VI respectively.

## 2. HEMT DEVICES

High Electron Mobility Field Effect Transistors (HEMTs) are swiftly substituting predictable MESFET technology in many of the applications like military, commercial etc., demanding for a low Noise Figures with large gain, mainly at millimeter (mm) wave frequency. HEMT device is also named as Modulation Doped Field Effect Transistor (MODFET).

The elementary moralities of operation are alike to those of the MESFETs. The foremost difference between HEMTs and MESFETs is due to the epitaxial layer in the structure. In case of HEMTs, different layers of material are developed in demand to enhance and outspread the Performa of the transistor. For example, III-V compound semi-conductors consuming GaAs as a substrate, the constituents used are AlGaAs and GaAs. These dissimilar layer arrangements produce heterojunction, as every layer consumes a varied bandgap. The most important point about the channel layer in the HEMT devices is the two-dimensional electron gas (2DEG) that results from the band-gap difference between  $\text{Al}_x\text{Ga}_{1-x}\text{As}$  and GaAs (or  $\text{Al}_x\text{Ga}_{1-x}\text{As}$  and  $\text{In}_x\text{Ga}_{1-x}\text{As}$ , in the case of the PHEMT).

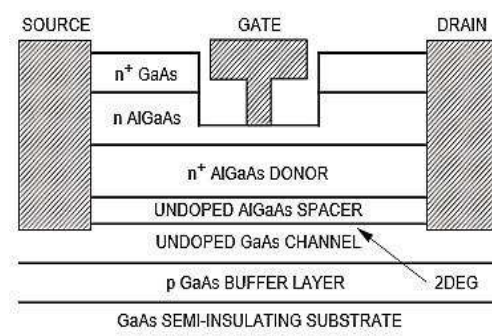

Fig -1: Basic HEMT structure

### 3. PROPOSED DESIGN OF DIFFERENTIAL LNA

The RF differential low noise amplifier is fashioned using HEMT devices. As per the architecture of an RF amplifier, the design proposed also consists of three stages. The proposed radio frequency amplifier using current mirror as load is shown in the Fig -2 below.

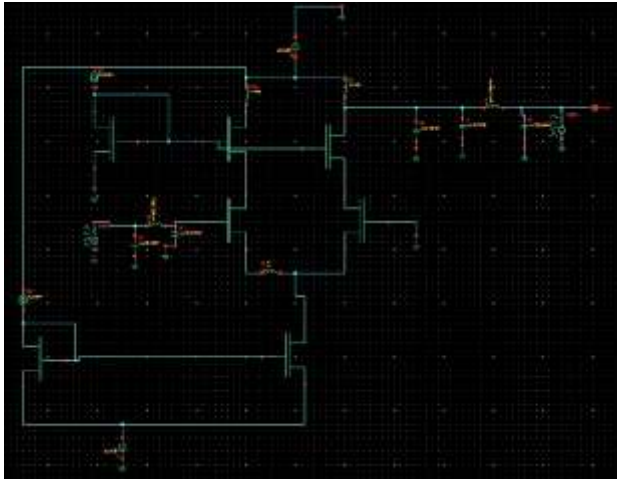

Fig -2 : Differential LNA with Current Mirror Load

#### 3.1. Input matching circuit:

Here again the input matching network considered is a Pi matching circuit. It consists of two capacitances of C1 and C2 having values 10.769fF and 35.252fF and inductor value of 895.505pH respectively. The purpose of consuming an input matching network is to equalize the impedance at source with the impedance at the input of an amplifying part. The Zin of the amplifying section depends on the load impedance connected at the amplifying stage output. As we know, π-matching circuit is used, as it offers some amount of regulation over bandwidth. The source and load resistance is 50Ω.

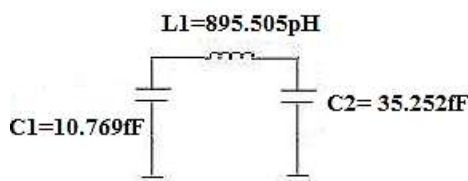

Fig -3: Input matching circuit

#### 3.2. Amplifying stage:

In this differential LNA circuit designed using HEMT; the current mirror load helps in driving the driver HEMT. This stage consists of 7 HEMT devices. All these devices are maintained with the same width i.e. 25μm and length of 105nm. The amplifying stage is designed to an operating frequency of 21.87GHz. The inductance and capacitance values are selected so as to obtain this operating

frequency. A DC voltage supply of 30V is used for biasing the devices in saturation. A source degeneration inductor of is used to provide a proper matching at the input side.

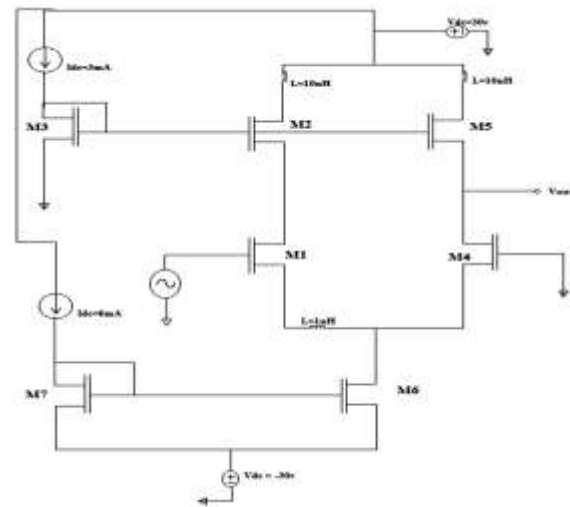

Fig -4: Differential Amplifier Stage using HEMT

#### 3.3. Output Matching Stage:

The output matching section is again a Pi network. The load here is fixed at 50ohms impedance. This impedance is used to match output with the output of the amplifying section. The capacitance and inductance values are as shown in the Fig -5.

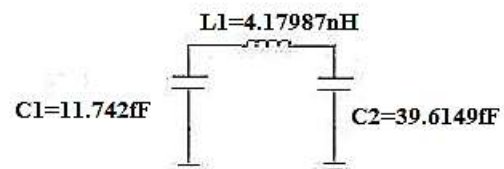

Fig -5: Output Matching Circuit

### 4. RESULTS

#### 4.1. Power Gain (Gp):

A Power Gain G<sub>p</sub>, is the relation between the amount of power conveyed to the load P<sub>load</sub> by the power at the input side P<sub>in</sub>,

$$G_p = \frac{P_{load}}{P_{in}}$$

G<sub>p</sub> is the tuned gain of a device where the outcome is offered by means of suitable load line L to generate particular amount of output power, and the incoming amount of power is matched for negligible reflection. [7] A G<sub>p</sub> of 18.8024dB was obtained for differential RF amplifier.

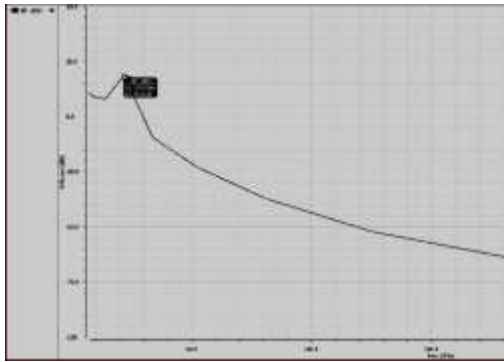

Fig -6: Power Gain of differential LNA at 21.87 GHz

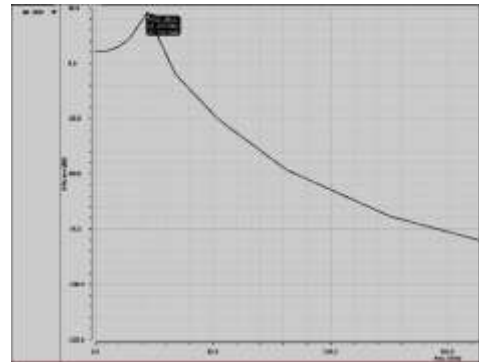

Fig -8: Available Gain of Differential LNA at 21.87 GHz

#### 4.2. Transducer Gain (G<sub>T</sub>):

Transducer Power Gain denoted as G<sub>T</sub>, is outlined as the fraction of the power conveyed to the load by an amplifier P<sub>load</sub>, to the source power obtained P<sub>avs</sub>, so

$$G_T = \frac{P_{load}}{P_{avs}}$$

A G<sub>T</sub> obtained for differential LNA is 15.87152dB.

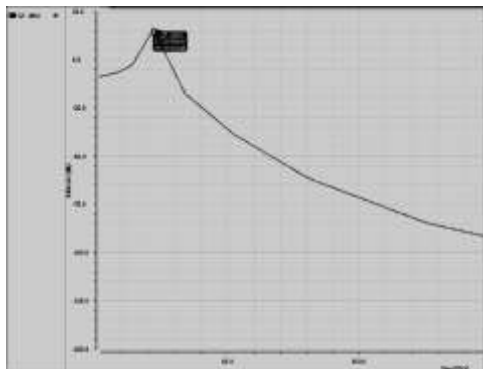

Fig -7: Transducer Power Gain at 21.87 GHz

#### 4.3. Available Gain (G<sub>A</sub>):

An Available Power Gain represented as G<sub>A</sub> is the proportion of the available power from the 2-port system P<sub>avn</sub>, to the power offered by the source P<sub>avs</sub>,

$$G_A = \frac{P_{avn}}{P_{avs}}$$

The gain obtained is tuned at frequency at 21.87GHz when the device is matched at the input terminal for having optimum Noise Figure and is matched at the output side for having lesser amount of reflection. [7]. A G<sub>A</sub> of 22.51215dB was obtained for the proposed design.

#### 4.4. Maximum Power Gain (G<sub>max</sub>):

When the input and output networks are designed simultaneously to calculate the maximum gain, there is no reflection at the source or load. The maximum power gain is given as

$$G_{max} = \left| \frac{s_{21}}{s_{12}} \right| (k - \sqrt{k^2 - 1})$$

In the above equation the term K is defined in the documentation. [8] A maximum power gain obtained for differential stage is 27.5221dB.

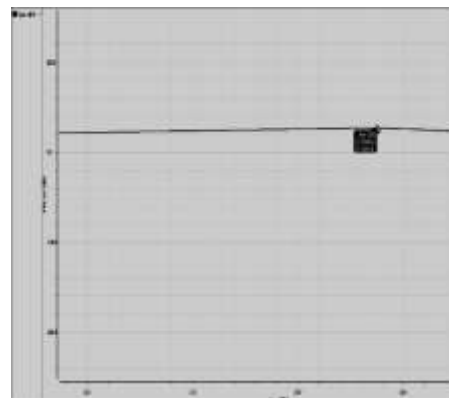

Fig -9: Maximum Power Gain For Differential LNA at 21.87 GHz

#### 4.5. Maximum Unilateral Power Gain (G<sub>umx</sub>):

A device is said to be unilateral when scattering parameter, S<sub>12</sub>=0. This suggests that the device network does not have an internal feedback. The above-mentioned condition is precisely tough to accomplish at higher frequency. Ideally, an external network can be used to improve feedback such that the influence of internal feedback network can be eliminated. The amplifier when operates only at VHF consuming narrow bandwidth the outcome is agreeable. [8]

A maximum gain that would be realized if the device remained unilateralized and conjugate matched is called the maximum unilateral power gain.

$$G_{umax} = \frac{1}{1-|S_{11}|^2} |S_{21}|^2 \frac{1}{1-|S_{22}|^2}$$

A  $G_{umx}$  of 25.44dB was obtained for the proposed design.

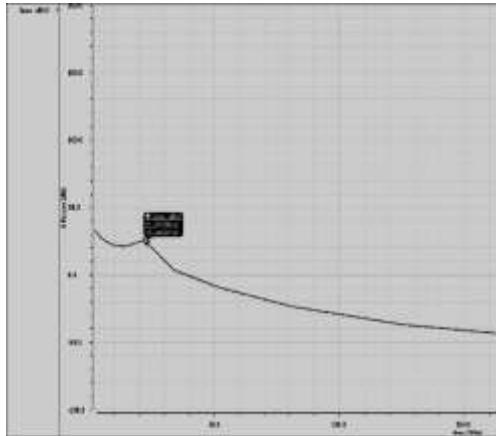

Fig -10: Maximum Unilateral Power Gain Differential LNA

#### 4.6. Maximum Stable Power Gain ( $G_{msg}$ ):

Maximum Stable Power Gain,  $G_{msg}$ , is stated same as  $G_{max}$  assigning the value of K as unity. [7] Therefore,

$$G_{max} = \left| \frac{S_{21}}{S_{12}} \right| (K - \sqrt{K^2 - 1})$$

Substituting the value of K, the above equation is reduced as

$$G_{msg} = \left| \frac{S_{21}}{S_{12}} \right|$$

A  $G_{msg}$  of 31.39185dB for differential RF Low noise amplifier.

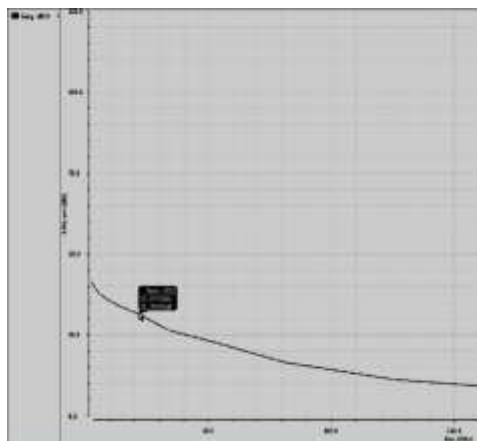

Fig -11: Maximum Stable Power Gain Of Differential LNA at 21.87 GHz

#### 5. CONCLUSION

By means of adequate literature survey and the sound knowledge on HEMT device, the block diagram of the amplifier with the design is projected. The software tool Cadence Virtuoso Editor was used to know about the I-V curves of HEMT devices. The benefits of the tool and the compatibility over the others, with the execution of Verilog-A file helped in forming the design required. Differential LNA using GaN HEMT shows better performance having a forward gain of 15.87152dB.

#### REFERENCES

- [1] B. Razavi, "CMOS technology characterization for analog and RF design," IEEE J. Solid-State Circuits, vol. 34, pp. 268-276, Mar. 1999.
- [2] Kavyashree.P, Dr. Siva S Yellampalli, "The Design of Low Noise Amplifiers in Nanometer Technology for WiMAX Applications", International Journal of Scientific and Research Publications, Volume 3, Issue 10, October 2013.
- [3] D.Jackuline Moni and Jenifer.T, Josephine Agaliya.A, "Design of Low Power Low Noise Amplifier Using 180nmTechnology", International Journal of Emerging Technology in Computer Science & Electronics (IJETCSE), ISSN: 0976-1353 Volume 8 Issue 1 –APRIL 2014.
- [4] E. O. Johnson, Physical limitation on frequency and power parameters of Si.
- [5] Rfamp.htm. Retrieved from <http://www.radioremembered.org>
- [6] Poon, Alan Siu Kei, "RF Power Amplifiers".
- [7] "Power, transducer, Available and insertion gain defined", Maury Microwave Corporation, March 2005.
- [8] Gonzalez, Guillermo; Microwave Transistor Amplifiers, Analysis and Design – Second Edition; Prentice-Hall Inc., Upper Saddle River, NJ 07458. ISBN 0-13-254335-4 (1984).