

Portable Supporting Device for Narcoleptic Patients

Dr. K. Rahimunnisa¹, R. Aadithya², S. Praveen³, K. Padmanathan⁴

¹Associate Professor, Department of ECE, Easwari Engineering College, Chennai, Tamil Nadu

^{2,3,4}UG students, Department of ECE, Easwari Engineering College, Chennai, Tamil Nadu

Abstract- Narcolepsy is a neurological sleep disorder which causes increased daytime sleepiness or sudden uncontrollable sleep episodes in patients. This supporting device for the people with narcolepsy basically detects the early onset of narcoleptic sleep in the patients and provides external disturbances using vibration motors to prevent them from falling asleep. It uses EEG which constantly monitors the brain waves and detects if there is an onset of narcoleptic sleep. After which the onset is prevented by the disturbances provided by the vibration motor which alerts the patient.

Key words-Narcolepsy, Brain waves, External disturbances, EEG sensor.

1. INTRODUCTION

Narcolepsy is a sleep disorder characterized by excessive daytime sleepiness and cataplexy - episodes of muscle weakness triggered by positive emotions[1]. Narcolepsy is a chronic neurological disorder which does not have any cure yet. It causes excessive sleepiness in patients and also sudden episodes of falling asleep which are uncontrollable and can occur even when the patients are involved in activities like talking, driving, etc. This greatly impacts them in several different ways as falling asleep while during certain activities like driving may lead to accidents and they are prone to some sort of danger due to the narcolepsy throughout the day due to the underlying fact that they can fall asleep suddenly at anytime without their control. The severity of the sleepiness is comparable with that experienced by a healthy person who has been sleep deprived continuously for 48-72 hours[2]. Not only that due to the excessive sleepiness even during the day can make it hard for them to concentrate and focus on activities, thus affecting their performance in day to day life and is also morally demeaning as their potential is vastly decreased and since they are prone to uncertain risks, they can't tend to do many activities alone and might always require a person monitoring and supporting them. Most of the patients with narcolepsy also have cataplexy which is the sudden loss of muscle strength which can sometimes be moderate or localized like just the closing of eye lids to a much severe complete loss of muscle strength throughout the body which may render in an inert state and might take time until they regain them. The onset of the narcoleptic sleep can easily be observed and detected through brain waves (Alpha, Beta, Sigma, Theta, Delta waves) using an EEG accurately.

1.2 LITERATURE SURVEY

Janell Wofford, 23 Feb 2015[3]. In this article, the author discussed the outstanding EEG findings in narcolepsy includes non-specific findings like, the onset of sleep in the narcoleptic patients is usually rapid and is found to be within 4 minutes. 94 cases were referred for this study of narcolepsy. In sleep analyses, for over 24 cases, the sleep was not deep or even light but rather at the drowsy or very light level. Unusual eye blinks, eye movements, were also observed.

Julie Flygare, JD and Sairam Parthasarathy, MD. January 2015[4]. In this paper, the probable cause for narcolepsy was found and analysed by the author. It was due to loss of hypocretin (orexin) receptor gene in the brain. A post-mortem of brain tissues of narcoleptic patients were used to identify the cause of narcolepsy. Loss of hypocretin neurons found as cluster of thousand cells in lateral hypothalamus. This is caused due to an autoimmune disorder with environment and genetic factors as additional contributors. Diagnosis of narcolepsy is followed by multiple nap tests.

Junko Mukai Sunao Uchida Shinichi Miyazaki Kyoko Nishihara Yutaka Honda. In J Sleep Res. 2003[5]. In this paper, the author discussed about the experiments conducted. Few drug native narcoleptic patients and some age matched normal volunteers underwent PSG (polysomnograms) on two consecutive nights. Rapid Eye Movement density and Electroencephalograph power spectral analysis were taken. Sleep onset REM (Rapid Eye Movement) periods and nocturnal sleep were observed. REM period duration across the night did not show increasing trend in normal people, but for narcoleptic people, it was high.

Plamen D. Dimitrov¹, Petar Petrov¹, Ivan Aleksandrov¹, Ivan Dimitrov², Mariyana Mihailova³, Galina Radkova¹, Raya Dimitrova¹ 2017 Jan-Mar,23:[6]. In this paper, the initial results show that there are unique Quantitative EEG differences between the groups of patients and the control group. The changes affect the potential levels of delta-, theta-, alpha-, and beta- frequency spectrums. The present study shows that some unique quantitative EEG findings in autistic patients. This is a step forward, aimed at defining specific neurophysiologic changes, in order to develop and refine strategies for early diagnosis of autism spectrum disorders, differentiation from other development conditions in childhood, detection of specific biomarkers and early initiation of treatment.

Büşra Ülker, Mehmet Barış Tabakcioğlu and Hüseyin Çizmeci Doruk Ayberkin 2017[7], In this paper, the major insight on how the attention and meditation values are determined from the five brain waves : Alpha, Theta, Delta, Gamma and Beta waves.

Dongha Lim, Chulho Park, Nam Ho Kim, Sang-Hoon Kim, and Yun Seop Yu 2014[8], In this paper the author stated about how falls can be detected by placing a sensor at the subject's chest and by observing the change in the acceleration sensor node.

1.3 PRE EXISTING TECHNIQUES

Narcoleptic patients unlike the common people have the need to be constantly monitored by someone so that they do not put themselves to any danger while performing the day to day activities by falling asleep or due to the uncontrollable sleep attacks which are fairly common in narcoleptic patients. Since the peak age of onset of Narcolepsy being 14 years ,it is no surprise that in a reported series of children with narcolepsy a range of serious psychological problems were consistently found like emotional lability, depression, difficult or aggressive behaviour, social withdrawal and isolation, and academic failure. They might fall asleep unknowingly and sleep for many hours and lose a major portion of their day which can be avoided. But always being monitored and requesting the support of someone reduces the morale of the narcoleptic patients as they cannot be independent like normal people. Thus a supporting device can allow them to be independent and also saves them from wasting useful hours and reduce

their risk of getting into danger by falling asleep without the monitoring or support from another person. The pre existing techniques to monitor sleep disorders generally involve sleep tests which are conducted in sleep labs. The patients are required to sleep in the lab while the lab technicians observe several data collected from the patients body while they sleep like the brain waves and oxygen levels in blood. For narcoleptic patients the monitoring is done during the day and a polysomnogram is obtained which helps to detect the type and adversity of the condition. But this method requires the patient to be in a lab and is tedious because a patients have to be monitored for long hours while being made to wear numerous wires and in a new environment where they do not feel comfortable.

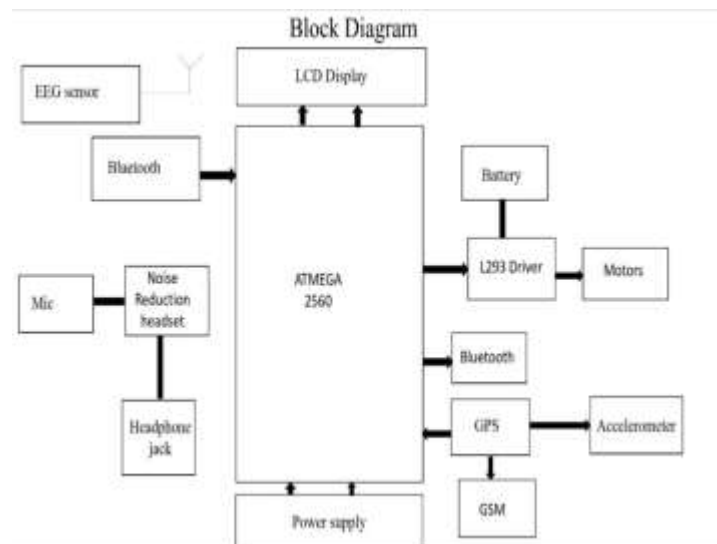

Figure 1 Block Diagram

1.4 PROPOSED WORK

These sleep tests include long observations involving lots of wires connected to the patient under observation and also the requirement of a lab to carry out the observation ensued by a detection and diagnosis. Such drawbacks can be easily overcome by using a Neurosky's Mindwave EEG sensor which can be used to monitor all the five brain waves (Alpha, Theta, Sigma, Beta, Delta waves) from which the onset of narcoleptic sleep can easily be detected almost instantly and the sleep can also be prevented or the person can be woken up by the external disturbances provided by the supporting device upon the detection of narcoleptic sleep onset and this method does not require a lab or several lab technicians and the main advantage is its standalone capability and also the portability. This is a pervasive method to detect

and support narcoleptic patients at anytime and anywhere almost instantly. A study which involved 20 healthy adults being whose brain waves were monitored by polysomnography technique and later analysed by polysomnography for the anomalies throughout a two session sleep observation schedule and later EEG sensor was used on the same adults and using the PSM as the gold standard.

The EEG technique to analyse and detect sleep disorders was found to be 87.5% accurate in terms of detection of narcoleptic sleep onset. The single electrode EEG provides real time Alpha, Beta, Theta, Sigma and delta waves from the patient's brain which was fed to a ATMEGA microcontroller which later triggers the vibration motors if the waves are below or above certain values. In this method onset of sleep in narcoleptic patients can be accurately measured and is reliable due to the data from earlier studies which have provided us with strong foundational knowledge about the precise changes in the various brain waves ensuing the onset of sleep and thus we have exact thresholds values above or below which if a brain wave falls then we can be certain about the occurrence of onset of sleep in the patients.

2. METHODOLOGY

Alpha, Beta, Theta, Delta and Sigma waves are primarily used in the detection of onset of narcoleptic sleep. These brain waves are recorded by the EEG sensor which is fed to the Microcontroller. The detection of onset of sleep is performed based on comparing the brain wave changes associated with sleep onset in normal people with the the brain wave changes associated with the narcoleptic sleep onset in patients. Mean delta and theta wave amplitudes will be higher for narcoleptic sleep onset when compared to the sleep onset in normal people. Mean alpha and sigma wave amplitudes will be lower for narcoleptic sleep onset when compared to sleep onset in normal people. Mean beta wave amplitude will not differ between the narcoleptic and normal sleep-onset process. The EEG sensor being used detects all the five types if brain waves and gives us two values mainly: Attention value and meditation value. If the values are above a threshold for the patients being monitored, then it is certain that onset of narcoleptic sleep is occurring and therefore they are about to fall asleep. After the detection, the microcontroller immediately triggers the vibration

motors which are strapped to the arms or any other viable spots in the body of the patients, which then vibrate thereby giving externally disturbances which will alert the patient that the onset is occurring thus preventing them from falling asleep. The EEG sensor in the form of a headset is connected to the microcontroller through Bluetooth modules connected to both the headset and the microcontroller. There is another portion to the project which consists of an accelerometer which detects the fall when cataplexy occurs in the patient. This is vital because if the person has experienced cataplexy or fallen asleep in a situation which puts their life in danger like while driving or in the middle of a dangerous activity where there is no room for mistakes. Although the vibration motors might wake them up soon they might already be in danger because of them falling asleep or experiencing cataplexy in an unlikely situation which might lead to an accident. Thus after the fall is detected by the accelerometer, then it is checked if the sensor has detected narcoleptic sleep in the person. If both of these occurrences are happening at once then a time window opens. Within which the person can press a button if he is safe and is not in danger. If he does not press the button within the time window it's most likely that the person is in danger. So after the time window ends the GPS present in the supporting device picks up the person's location at that moment. The latitude and longitude data is then sent to a number (the number of a person close to the patient probably a family member) using GSM module. Thus this enables the patient to be completely ¹independent even at times of unprecedented danger. The different brain waves being detected and the inferences from their amplitudes are shown in the table 1.

Table 1: Frequency of brain waves and corresponding inferences*

Brainwave Type	Frequency range	Mental states and conditions
Delta	0.1Hz to 3Hz	Deep, dreamless sleep, non-REM sleep, unconscious
Theta	4Hz to 7Hz	Intuitive, creative, recall, fantasy, imaginary, dream
Alpha	8Hz to 12Hz	Relaxed, but not drowsy, tranquil, conscious
Low Beta	12Hz to 15Hz	Formerly SMR, relaxed yet focused, integrated
Midrange Beta	16Hz to 20Hz	Thinking, aware of self & surroundings
High Beta	21Hz to 30Hz	Alertness, agitation

¹ * from Mindwave User Guide from Neurosky Brain-Computer interface technologies

3. RESULTS AND CONCLUSION:

Upon the onset of narcoleptic sleep the EEG sensor detects it and sends it to the microcontroller. Then the vibrational motors are made to vibrate which wakes up the patient. The accelerometer sensor also detect a fall and it checks with the EEG sensor whether the person is experiencing narcoleptic sleep and if they are, then a message will be sent containing the location of the patient unless they press a button within a time window after falling. The attention values are indicated in a LCD monitor and the type of sleep is also indicated. The various brain waves can also be observed using Labview software.



Figure 2 LCD when patient is in Normal State

The figure 2 shows the output displayed at LCD when the EEG detects the patient to be in Normal state.



Figure 3 LCD when patient is in High Sleep State

The figure 3 shows the output displayed at LCD when the EEG detects the patient to be in High Sleep.

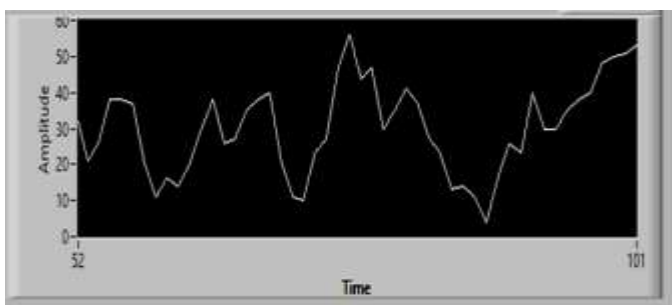

Figure 4 Raw data obtained from EEG sensor

The raw EEG data obtained from the EEG sensor without splitting into the five different brain waves can be viewed in LabVIEW evaluation software as shown in figure 4.

Thus this supporting device allows narcoleptic patients to be truly independent and live their day to day lives without someone constantly monitoring or helping them, the device wakes them up whenever they fall asleep and also inform another person when the patient is in plausible danger. More improvements can be done in this device by making it smaller and making the vibration motors more effective in the future.

4. REFERENCES:

- [1] C.R.Burgees and T.E.Scammell. J Neurosci. "Narcolepsy: neural mechanisms of sleepiness and cataplexy" in 2012 Sep 5;32(36):12305-12311.
- [2],[4] Julie Flygare, JD and Sairam Parthasarathy, MD. January "Narcolepsy: Let the Patient's Voice Awaken Us!" In 2015 Volume 128, Issue 1, Pages 10-13
<https://doi.org/10.1016/j.amjmed.2014.05.037>
- [3] Janell Wofford "The EEG in Narcolepsy" Pages 47-52 | Published online: 23 Feb 2015
- [5]Junko Mukai Sunao Uchida Shinichi Miyazaki Kyoko Nishihara Yutaka Honda. "Spectral analysis of all-night human sleep EEG in narcoleptic patients and normal subjects" In J Sleep Res. 2003 Mar;12(1):63-71.
- [6] Plamen D. Dimitrov¹, Petar Petrov¹, Ivan Aleksandrov¹, Ivan Dimitrov², Mariyana Mihailova³, Galina Radkova¹, Raya Dimitrova¹ Department of Psychiatry and Medical Psychology, Faculty of Medicine, Medical University of Varna, "Quantitative EEG comparative analysis between Autism spectrum disorder (ASD) and Attention deficit hyperactivity disorder (ADHD)" in Bulgaria Journal of IMAB - Annual Proceeding (Scientific Papers). 2017 Jan-Mar, 23:.
- [7] Büşra Ülker, Mehmet Barış Tabakcioğlu and Hüseyin Çizmeçi Doruk Ayberkin "Relations of Attention and Meditation Level with Learning in Engineering Education" in ECAI 2017 - International Conference – 9th Edition Electronics, Computers and Artificial Intelligence 29 June -01 July, 2017, Targoviste, ROMÂNIA.

[8] Dongha Lim, Chulho Park, Nam Ho Kim, Sang-Hoon Kim, and Yun Seop Yu” Fall-Detection Algorithm Using 3-Axis Acceleration: Combination with Simple Threshold and Hidden Markov Model” 10 February 2014; Accepted 19 August 2014; Published 17 September 2014.