

# A Review on Improvement of Power Quality and Displacement Factor using IVDFC

Prajakta R. Kamble<sup>1</sup>, Shubhangi S. Kangale<sup>2</sup>, Prof. CH. Mallareddy<sup>3</sup>

<sup>1,2</sup>Student, Dept. of Electrical Engineering, Fabtech College of Engineering, Sangola, India

<sup>3</sup>Professor, Dept. of Electrical Engineering, Fabtech College of Engineering, Sangola, India

\*\*\*

**Abstract** – In recent years, concerns over the power quality (PQ) have been rapidly increasing because of a broader application of nonlinear electronic devices in power apparatus and systems. Power quality has a significant influence on high-technology equipment's related to communication, advanced control, automation, precise manufacturing technique and on-line service. Power quality problems include transients, sags, interruptions and other distortions to the sinusoidal waveform. One of the most important power quality issues is voltage sag that is a sudden short duration reduction in voltage magnitude between 10 and 90 % compared to nominal voltage. DVR is an inverter based voltage sag compensator, it regulates voltage within acceptable tolerances and meet the critical sensitive power quality needs. In this paper, interline dynamic voltage restorer (IDVR) is going to be designed for reducing the disturbances due to voltage sag under abnormal conditions which consists of dynamic voltage restorers (DVR) and a common DC link.

**Key Words:** Power Quality, Voltage Sag, Displacement Factor, Dynamic Voltage Restorer (DVR), Interline Dynamic Voltage Restoring and Displacement Factor Controlling Device (IVDFC), etc.

## 1. INTRODUCTION

Power quality is one of major concerns in the present era. It has become important, especially, with the introduction of sophisticated devices, whose performance is very sensitive to the quality of power supply. In many countries, the effects of lack of power quality (PQ) have been resulting in wastage of several billions of dollars every year. Now a days, most of the PQ problems are due to different fault conditions. These conditions cause voltage sag, voltage swell, transients, voltage interruption and harmonics. These problems may cause the apparatus tripping, shutdown commercial, domestic and industrial equipment, and miss process of drive system. In a large power system voltage sag is considered to be the most common and critical power quality (PQ) issue. With the advent of power-semiconductor devices many PQ devices came into existence. Dynamic voltage restorer (DVR) and distribution static compensator (D-STATCOM) are normally employed as voltage sag mitigation devices.

The Static Series Compensator (SSC), commercially known as Dynamic Voltage Restorer (DVR), is best suited to

protect sensitive loads against such incoming supply disturbances. DVR is a cost effective solution for the protection of highly sensitive loads at medium voltage level. However, for lower voltage applications, the DVR may be cost-ineffective compared to the uninterruptible power supply. It is recently being used as the active solution for mitigation of power quality problems.

An interline dynamic voltage restorer (IDVR) is invariably employed in distribution systems to mitigate voltage sag/swell problems. An IDVR merely consists of several dynamic voltage restorers (DVRs) sharing a common dc link connecting independent feeders to secure electric power to critical loads. While one of the DVRs compensates for the local voltage sag in its feeder, the other DVRs replenish the common dc-link voltage. For normal voltage levels, the DVRs should be bypassed. Instead of bypassing the DVRs in normal conditions, this project proposes operating the DVRs, if needed, to improve the displacement factor (DF) of one of the involved feeders. DF improvement can be achieved via active and reactive power exchange (PQ sharing) between different feeders.

## 2. Dynamic Voltage Restorer

Dynamic Voltage Restorer is a series connected power electronics based device that can quickly mitigate the voltage sag in the system and restore the load voltage to the pre-fault value. Hence, it can eliminate severe sag and minimize the risk of load tripping at very deep sags. It also regulates voltage within acceptable tolerances and meet the critical sensitive power quality needs.

Figure 1 shows basic structure of DVR which consists of:

- 1. Energy Storage:** This unit is responsible for energy storage in DC form. Flywheels, Batteries, superconducting magnetic energy storage (SMES) and super capacitors can be used as energy storage devices. Usually batteries are used to provide the required energy for compensation of load voltage during abnormal conditions which is economical compared to shunt connected devices. In low power applications, photovoltaic cells can also provide energy.
- 2. Injection/ Booster transformer:** The Injection / Booster transformer is a specially designed transformer that attempts to limit the coupling of

noise and transient energy from the primary side to the secondary side. Its main tasks are:

- It connects the DVR to the distribution network via the HV-windings and transforms and couples the injected compensating voltages generated by the voltage source converters to the incoming supply voltage.
  - In addition, the Injection / Booster transformer serves the purpose of isolating the load from the system (VSC and control mechanism).
3. **Harmonic Filter:** As DVR consist of power electronic devices, the possibility of generation of self-harmonics is there so harmonic filter is also become a part of DVR. The main task of harmonic filter is to keep the harmonic voltage content generated by the VSC to the permissible level.
  4. **DC Charging Circuit:** The dc charging circuit has two main tasks.
    - The first task is to charge the energy source after a sag compensation event.
    - The second task is to maintain dc link voltage at the nominal dc link voltage.

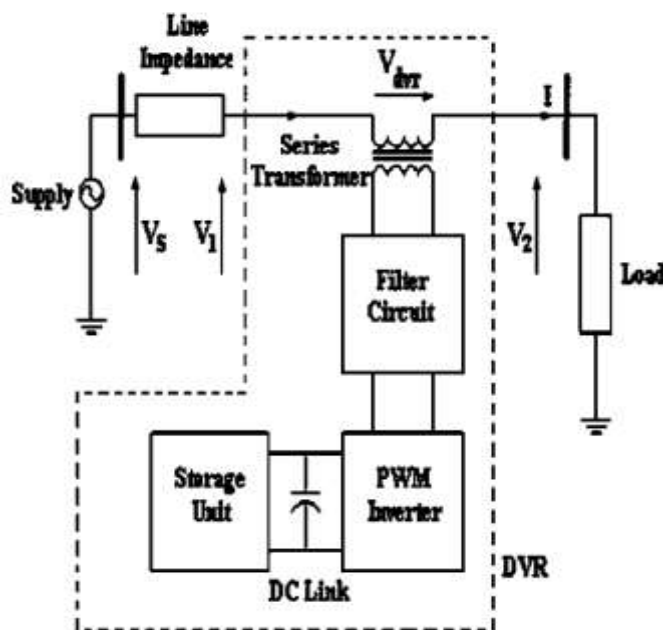

Fig -1: Basic Structure of DVR

5. **Voltage Source Converter:** A VSC is a power electronic system consists of a storage device and switching devices, which can generate a sinusoidal voltage at any required frequency, magnitude, and phase angle. For DVR application, the VSC is used to momentarily replace the supply voltage or to generate the part of the supply voltage which is absent.
6. **Bypass Switch:** It is used to protect the inverter from High current in the presence of unwanted conditions. During the occurrence of a fault or a

short circuit, DVR changes it into the bypass condition where the VSI inverter is protected against over current flowing through the power semiconductor switches.

### 3. Interline Dynamic Voltage Restorer

Interline Dynamic voltage restorer (IDVR) is a method of overcoming voltage sags which occur in electrical power distribution. It is employed in abnormal condition. The primary function of IDVR is to inject a voltage with certain magnitude and phase angle. It consists of dynamic voltage restorers (DVRs) sharing a common DC-link to secure electric power to critical loads. While one of the DVR compensates for voltage sag, the other DVR fills up the DC-link voltage. During normal condition, an IDVR is used to improve the displacement factor (DF) of one of the involved feeders. DF improvement is achieved by active and reactive power exchange (PQ sharing) between different feeders. Voltage sags reduce the efficiency. IDVR saves energy through voltage injections that can affect the phase and wave shape of the power being supplied. The basic principle of interline dynamic voltage restorer is to inject a voltage of the necessary magnitude and frequency to restore the load side voltage to the desired amplitude and waveform, even when the source voltage is unbalanced or distorted. The IDVR can generate or absorb independently controllable real and reactive power at the load side.

When the feeder is switched to power control mode, the in-phase voltage component represents the active power to be pumped/ absorbed by that feeder to/ from the DC-link (Active Power Control).

When the feeder is switched to power control mode, the quadrature voltage component is used to keep the load voltage magnitude of that feeder constant (Load Voltage Control).

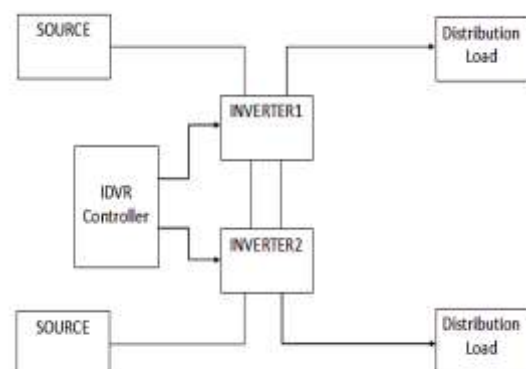

Fig -2: Block Diagram of IDVR

The main objective is to maintain voltage quality using IDVRs with improved DF in feeders. In this block diagram, there are two power system feeders. The first system represents that it is in normal condition. When fault occurs

in second system, it will acts & adjust the dc link voltage. There are two converters used for two IDVR feeders, the converter will maintain and injects the active and reactive power when the system fault occurs. The work of the controller is to compare the two feeder voltages and dc link voltages using dc voltage controller & ac voltage controller. This control value, DF error value & PQ enable value switching to the control output, it gives to the PWM control. The circuit diagram of an Interline Dynamic Voltage Restorer using voltage controlled source is shown in Figure 3. The 3-phase voltage source inverter is connected to the secondary side of the isolation transformer. Whenever fault occurs, the IDVR controller injects voltage to the transmission line. Here, we are using MOSFET as switching devices.

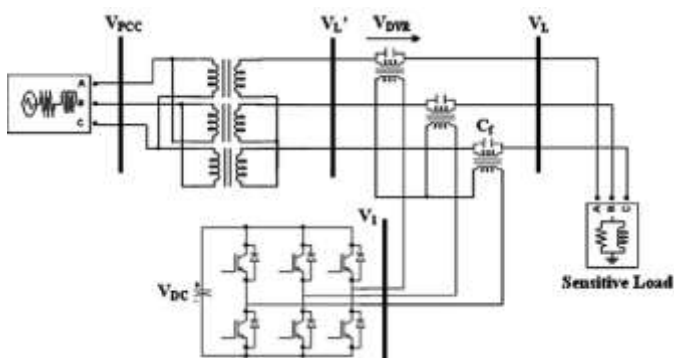

Fig -3: Circuit Diagram of IDVR

#### 4. Proposed Method

During normal operating conditions (i.e., all feeders are healthy), the DVRs are typically bypassed via bypass switches, or they can be alternatively used for load sharing purposes. Instead of bypassing the IDVR in normal operation, this paper proposes a new operational mode, namely PQ sharing mode, to improve the DF of one of the involved feeders by sharing active and reactive power among different system feeders through the buffering stage (the common dc link). To apply this concept, several constraints are observed throughout the paper. The proposed work is in progress with help of MATLAB simulation.

Similar to the IDVR, the two-line IVDFC simply consists of two voltage source converters connected back-to-back with a common dc link, as shown in Fig-4. For normal voltage levels, achieving active power exchange between the feeders (from sourcing feeder to receiving feeder), requires controlled voltage injection in each feeder by the corresponding converter (see Fig-4). This injected voltage should not perturb the load voltage magnitude of both feeders; therefore, both converters are operating under PC mode.

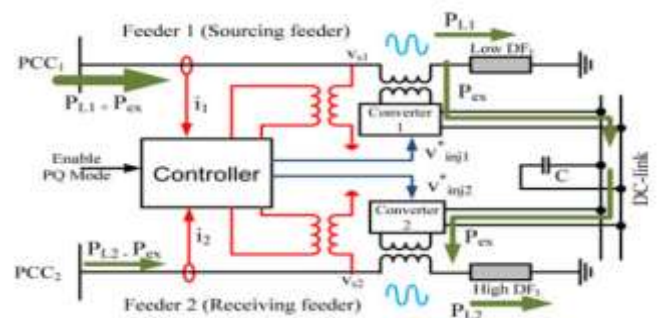

Fig -4: Operation of IDVR with DF improvement during normal condition

#### CONCLUSION

The proposed technique could identify the voltage sag and is capable of mitigating the sag by maintaining the load voltage magnitude at desired voltage. This paper proposes a new operational mode for the IDVR to improve the DF of different feeders under normal operation. The same system can also be used under abnormal conditions for voltage sag/swell mitigation.

#### REFERENCES

- [1] Arindam Ghost "Power Quality Enhancement using Power Devices", Klumer Academic Publishers, 2012
- [2] M.Vilathgamuwa, A.A.D. RanjithPeera, and S.S.Choi, "Performance improvement of dynamic voltage restorer with closed-loop load voltage and current-mode control," IEEE Trans. Power Electron., vol .17,no.5,pp.824-834, Sep 2013.
- [3] S.M.Kannan, P.Renuga, and A.R.Grace, "Application of fuzzy logic and particle swarm optimization for reactive power compensation of radial distribution systems," IEEE. Electr Syst., 6-3, vol.6, no.3, pp.407-425, 2010.
- [4] P.C.Loh, D.M.Vilathgamuwa, S.K.Tang, and H.L.Tong, "Multilevel Dynamic Voltage Restorer", International Conference On Power System Technology, vol.2, pp.1673-1678, November 2011.
- [5] A.Massoud, S.Ahmed, P.Enjeti, and B.W.Williams, "Evaluation of a multilevel cascaded type dynamic voltage restorer employing discontinuous space vector modulation," IEEE Trans. Ind. Electron., vol.57, pp.2398-2410, Jul. 2010.
- [6] D.Mahinda, H.M.Wijikoon, and S.S.Choi, "A novel technique to compensate voltage sags in multi-line distribution system-the interline dynamic restorer," IEEE Trans. Ind. Electron, vol.53, no.5, pp.1603-1611, Oct. 2006
- [7] L.Gyugyi, K.K.Sen, and C.D.Schauder, "The interline power flow controller concept: A new approach to power flow management in transmission