

Energy Efficiency Audit using Raspberry-pi

Prof. Pallavi Jha, Miss. Pranjali Marne, Miss. Aishwarya Bhosale, Mr. Rohit Lute

¹Professor, Dept, of Computer Engineering, ISB&M SOT, Pune, Maharashtra, India

^{2,3,4}Student, Dept, of Computer Engineering, ISB&M SOT, Pune, Maharashtra, India

Abstract - Home security is turning into necessary these days because the potentialities of intrusion rate are changes daily. Safety from thieving, and fireplace are the foremost vital needs of home security system for individuals.

This unit talks concerning the essential definitions required to know the Project higher and more defines the technical criteria to be enforced as a vicinity of this project. Smart house is a concept that uses information technology to observe the setting, control the electronic devices and communicate to outside world.

With advancement of technology things are getting less complicated and easier for people. Automation is that the use of management systems and knowledge technologies to scale back the requirement for human add the assembly of products and services. In the scope of industrialization, the automation becomes higher step towards mechanization. Automation decreases the requirements of the labor.

This system reduces the rate of power consumption. The web server generates a total power consumption report of every electrical devices with the help of controller. By using this system, users will be capable of know their total uses of power consumption and cost of the power consumption. This system decreases the overuses of electricity and reduces the cost of the electricity bills.

Key Words: automation, power consumption, mechanization.

1. INTRODUCTION

In today's world, the term Internet Of Things (IOT) is growing rapidly. The term IOT which refers to the huge network of the devices embedded with hardware, software, electronics and enables these things to connect with each other, collect the data and exchange the data with each other.

IOT becomes essential part of our day to day life in terms of innovation, research, intelligence, automation and so on. Some appliances in home/industry requires more power. This leads to increasing the electricity bill. One of the solution of decreasing consumption of electricity rate is to monitor the how electricity is being consumed by the devices, and from this result analysis the decision of control the electronic devices being powered.

The system can provides report to the users of how much amount of energy consumption will be allow and from this

report users will be decided and adjust their usage of power. Saving energy is of great important as compared to wastage of energy.

Automation plays associate more and more vital role within world and also in day to day expertise. Through this project we've got tried to indicate automatic management of a home which result of that saved the power in some amount.

2. LITERATURE SURVEY

To reduces the consumption of power some researchers design a wireless sensor network for smart energy meter using Zigbee module. Zigbee module is low cost devices for monitoring the application. It also low power.

With the help of previous system, design an IOT based system using Zigbee module with Wi-Fi access point to monitoring the energy consumption.

To monitoring the rate of energy, some researchers build a efficient module using GSM and controller. This system reduces the cost of energy bills.

Smart energy meter uses GSM module and web pages. This system is the modification of already installed meter in our home. It reduces the high power level.

Now-a-days, smart home concepts are growing rapidly. To efficiently controlling the operating time of electronic appliances smart energy control system is helpful. It reduces the rate of the power consumption.

3. HOME AUTOMATION

Home/office automation is that the management of any electronics appliances in our house or workplace. Automation of Home/office is one in all the foremost developments in technology of the house that has return on in decades. There are many merchandise on the market nowadays that permit us management over the devices mechanically, either by remote control; or perhaps by voice command.

The proposed System is based on Raspberry-Pi microcontroller.

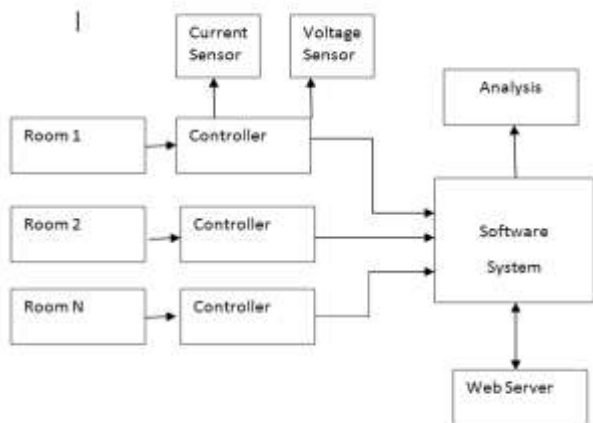

4. PROPOSED SYSTEM

This system uses various components. Proposed system works with the help of following modules:

- Controller is the center processing unit of the system and responsible for communication between the digital energy meter and web server in order to read the meter parameters and display at web server for the power management system.
- There are two main parts in our system implementation design, the first one is the digital energy meter with Controller and the second one is the web server for power management system.

4.1 Raspberry-Pi

Raspberry-Pi is the small sized computer that are responsible for doing everything that you had expecting from desktop computer. The Compute Module 1, Compute Module 3, and Compute Module 3 Lite of Raspberry-Pi include memory, Processor and power circuitry.

Raspberry-Pi is used in this system for controller purpose. In this system, Current sensor gives the senses current to Raspberry-Pi Controller and Voltage sensor provides senses voltage to the Raspberry-Pi Controller. Raspberry-Pi is responsible for calculating the total amount of energy consumption rate.

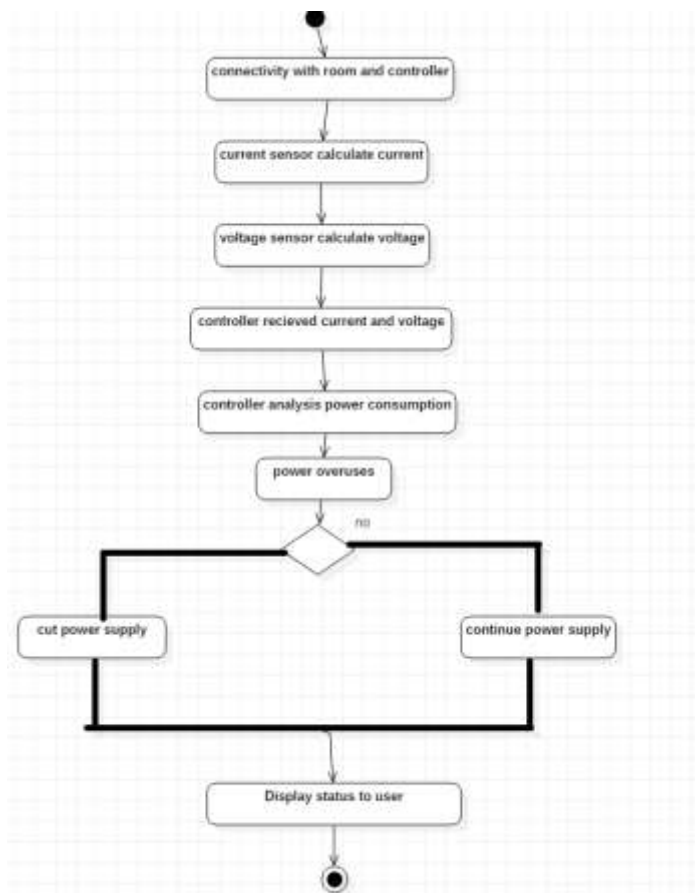

4.2 Current Sensor

It gives the economical solutions for sensing current in industrial area, communications systems, etc. The device package permits for simple implementation by the client. Current sensor is responsible for sensing the total amount of current generated by electrical devices.

4.3 Software System

We can On / Off device using web page where we can host it on Server. If Current sensor cross the line then it will give Notification to the user. Then user can On Off the device from the webpage from anywhere.

4.4 Technologies

Front End: Java Python.

Back End: MySQL If needed.

4.5 Web Server

Controller provides report of total power consumption to web server. Web Server will be responsible to analysis the power consumption rate.

We can handle device from the webpage, User can ON off the device from the Server request and response.

5. RESULT

Finally we get total power consumed value using our system. According to that value appliances will get turn off after exceed the set value.

6. CONCLUSIONS

In this paper, we proposed the System For Efficient Energy Consumption with the help of Internet Of Things(IOT).

This proposed system can reduces the total rate of power consumption and also reduces the electricity bill. With the help of this system users will be capable of continuously monitoring the power consumption of his/her devices.

7. REFERENCES

- [1] Somchai Thepphaeng; Chaiyod Pirak. Design and Implementation of Wireless Sensor Network and Protocol for Smart Energy Meter. 2011 International Conference on Circuits, System and Simulation IPCSIT vol.7 (2011) © (2011)IACSIT Press, Singapore.
- [2] Chih-Yung Chang,Chin-Hwa Kuo,Jian-Cheng Chen and Tzu-Chia Wang Design and Implementation of an IoT Access Point for Smart Home.Applied Science;ISSN 2076-3417.
- [3] Su, J.H.; Lee, C.S.; Wu, W.C. The Design and Implementation of a Low-Cost and Programmable Home Automation Module. IEEE Trans. Consum. Electron. 2006, 52, 1239– 1244.
- [4] Shuaib, K.; Boulmalf, M.; Sallai, F.; Lakas, A. Co-Existence of ZigBee and WLAN, a Performance Study. In Proceedings of the 2006 IFIP International Conference on Wireless and Optical Communications Networks, Bangalore, CA, USA, 11–13 April 2006; pp. 1–6.
- [5] S.Muthupandian, M.Maheswaran, R.S.Raja, R.Ajithkumar, SMART ENERGY METER USING IOT . International Journal of Emerging Technology in Computer Science & Electronics (IJETCSE) ISSN: 0976-1353 Volume 25 Issue 5 – APRIL 2018