

Smart Dustbin

Mr. Varun Chaudhary¹, Mr. Rohit Kumar², Mr. Anil Rajput³, Mr. Manvendra Singh⁴,

ER. Thakurendra Singh⁵

^{1,2,3,4}Department of Electronics & Communication Engineering, Raja Balwant Singh Engineering Technical Campus
Agra, Uttar Pradesh, India

⁵Department of Electronics & Communication of Engineering, Raja Balwant Singh Engineering Technical Campus
Agra, Uttar Pradesh, India

Abstract - As people are getting smarter so are the things. While the thought comes up for Smart cities there is a requirement for Smart waste management. The idea of Smart Dustbin is for the Smart buildings, Colleges, Hospitals and Bus stands. The Smart Dustbin thus thought is an improvement of normal dustbin by elevating it to be smart using sensors and logics. Smart dustbins is a new idea of implementation which makes a normal dustbin smart using ultrasonic sensors for garbage level detection and sending message to the user updating the status of the bin using GSM module. As soon as the dustbin is full a Smart Solid Waste collecting system. It is a common sight to witness garbage spilled out in and around the dustbins. The area around an improperly maintained dust bins can house disease spreading insects like mosquitoes, flies, bees and driver ants. The environment around a dustbin is also conducive for increasing the pollution level in air. Air pollution due to a dustbin can produce bacteria and virus which can produce life threatening diseases in human beings.

Key Words: Ultrasonic Sensor, GSM module, Arduino uno, LCD, Servo Motor etc.

1. INTRODUCTION

As the world is in a stage of up gradation, there is one stinking problem we have to deal with. Garbage! In our daily life, we see the pictures of garbage bins being overfull and all the garbage spills out. This leads to the number of diseases as large number of insects and mosquitoes breed on it. A big challenge in the urban cities is solid waste management not only in India but for most of the countries in the world. Hence, such a system has to be build which can eradicate this problem or at least reduce it to the minimum level. The project gives us one of the most efficient ways to keep our environment clean and green. The smart city concept is still new in India, although it has received a lot of attention in few years when our present prime minister gave the idea of building 100 smart cities throughout India. Now, with the upcoming large number of smart cities, large numbers of responsibilities are also required to be fulfilled. The prime need of a smart lifestyle begins with cleanliness and cleanliness begins with dustbin. A society will get its waste dispatched properly only if the dustbins are placed well and collected well. The main problem in the current waste management system in most of the Indian cities is the

unhealthy status of dustbins. In this paper we have tried to upgrade the trivial but vital component of the urban waste management system,

1.1 Literature Review

1. 1T WINKLE SINHA, 2K. MUGESH KUMAR, 3P. SAISHARAN (5, May 2015) proposed Smart Dustbins can prevent the accumulation of the garbage along the roadside to a great extent thereby controlling the widespread of many diseases. It can prevent pollution and also prevent the consumption of the spread out garbage by the street animals. This Smart Dustbin can contribute a lot towards a clean and hygienic environment in building a smart city. [1]

2. Swati Sharma*1 & Sarabjit Singh (May, 2018) proposed smart dustbin management system using IoT as a hardware and ionic framework as our software insures the cleaning of dustbins soon when the garbage level reaches its maximum. If the dustbin is not cleaned in specific time, then the record is sent to the higher authority in our case the admin who can take appropriate action against the concerned employee. This system also shows the use of PIR sensor, IR sensor and APR module. When some motion is detected by the PIR sensor it opens the gate of West dustbin using the servo motor and when the PIR detects the motion APR module gives the information fed into it of minimum 30 sec. For our lucrative part that is shoe polish we have used IR sensor and to rotate the brush we have used the DC motor. [2]

Narayan Sharma, Nirman Singha, Tanmoy Dutta (9, September-2015) proposed The smart-bin designed will be sending data about the levels of garbage collected in different parts of the city/town. The dataset created can be analyzed to gain lots of insights. The collected data set over a period of time will create a historical data set. [3]

1. Fady E. F. Samann (28 June 2018.) proposed system is based on Arduino Nano board and an ultrasonic sensor to monitor the fullness level of the container and give SMS alerts using a GSM module. The system is powered by lithium battery power bank supported by solar cell panel. The system provides an option of charging external portable devices using the power bank. Moreover, the system will store usage events, recorded by PIR sensor, and fullness

events on a memory card, which is also used to play audio message using a speaker, when the bin is being used. Finally, the system is implemented successfully with an acceptable overall cost for the intended application. The system performance was found satisfactory according to the obtained test results.[4]

U. NAGARAJU, RITU MISHRA, Chaitanya Kumar, Rajkumar (06 May 2017.) In the recent decades, Urbanization has increased tremendously. At the same phase there is an increase in waste production. Waste management has been a crucial issue to be considered. This paper is a way to achieve this good cause. In this paper, smart bin is built on a microcontroller based platform Arduino Uno board which is interfaced with GSM modem and Ultrasonic sensor. Ultrasonic sensor is placed at the top of the dustbin which will measure the stature of the dustbin. The threshold stature is set as 10cm. [5]

1.2 PRAPOSED SYSTEM

In present day the dustbin is overflown,the proposed system will help to avoid the overflow of dustbin because Breeding of mosquitoes and houseflies occur mainly in garbage which are a major cause for various diseases like malaria, dengue, chikungunya etc. This also causes headache and increase in the stress level . It will give the real time information about the level of the dustbin. It will send the message immediately when the dustbin is full. Deployment of dustbin based on actual needs. Cost of this system is minimum The resources are available easily. Improves environment quality by reducing the smell and make the cities clean. It is open automatically without touch lid. It is keep to provide environment clean.

2. METHODELOGY

2.1 Block Diagram

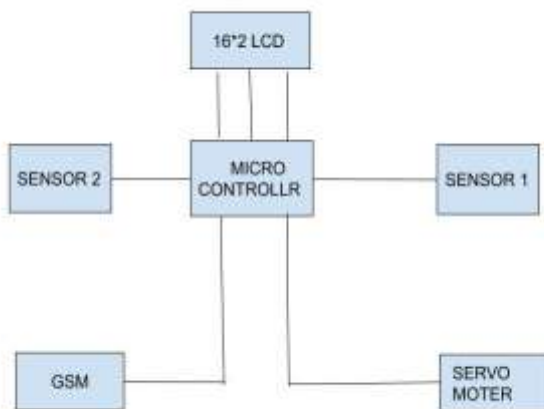

Figure 1. Block diagram of project

the basic operation of the system. The fullness status of the bin is determined by calculating the distance between the lid of the bin and the trash by using a sensor. A distance threshold will be set according to the bin dimensions. When the distance measuring sensor indicates that the bin is full, then a microcontroller board will control a GSM module to send SMS alert, that contains bin ID and alert message, to a predefined phone number. The location of the bin is predefined by a sanitary worker who will identify the filled bin by its ID, which received by the SMS alert. The system will return to default operation when the bin is emptied by the sanitary worker.

3. HARDWARE DISCRPTION

3.1 ULTRASONIC SENSOR:

As the name indicates, ultrasonic sensors measure distance by using ultrasonic waves. The sensor head emits an ultrasonic wave and receives the wave reflected back from the target. Ultrasonic Sensors measure the distance to the target by measuring the time between the emission and reception.

An optical sensor has a transmitter and receiver, whereas an ultrasonic sensor uses a single ultrasonic element for both emission and reception. In a reflective model ultrasonic sensor, a single oscillator emits and receives ultrasonic waves alternately. This enables miniaturization of the sensor head.

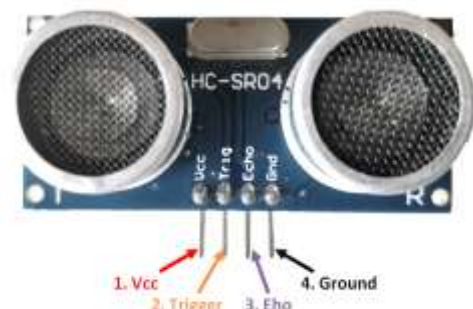

Figure 2. ultrasonic sensor

3.2 GSM 900 :

GSM (Global System for Mobile communications) is an open, digital cellular technology used for transmitting mobile voice and data services. GSM differs from first generation wireless systems in that it uses digital technology and Time Division Multiple Access (TDMA) transmission methods. GSM is a circuit-switched system that divides each 200kHz channel into eight 25kHz time-slots. GSM operates in the 900MHz and 1.8GHz bands in Europe and the 1.9GHz and 850MHz bands in the US. The 850MHz band is also used for GSM and 3GSM in Australia, Canada and many South American countries. GSM supports data transfer speeds of up to 9.6 kbit/s, allowing the transmission of basic data services such

as SMS (Short Message Service). Another major benefit is its international roaming capability, allowing users to access the same services when travelling abroad as at home. This gives consumers seamless and same number connectivity in more than 210 countries.



Figure 3 GSM module

3.3 ARDUINO UNO : Arduino is an open-source electronics platform based on easy-to-use hardware and software. Arduino boards are able to read inputs - light on a sensor, a finger on a button, or a Twitter message - and turn it into an output - activating a motor, turning on an LED, publishing something online. You can tell your board what to do by sending a set of instructions to the microcontroller on the board. To do so you use the Arduino programming language (based on Wiring), and the Arduino Software (IDE), based on Processing.

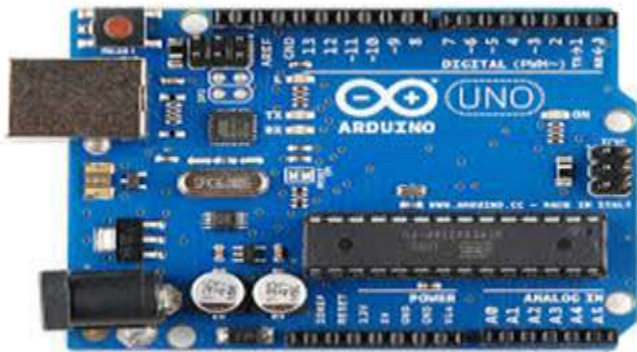

Figure 4 Arduino uno

3.4 LCD:

1. LCDs (Liquid Crystal Displays) are used for displaying status or parameters in embedded systems.
2. LCD 16x2 is a 16 pin devices which has 8 data pins (D0-D7) and 3 control pins (RS, RW, EN). The remaining 5 pins are for supply and backlight for the LCD.

3. The control pins help us configure the LCD in command mode or data mode. They also help configure read mode or write mode and also when to read or write.

4. LCD 16x2 can be used in 4-bit mode or 8-bit mode depending on requirement

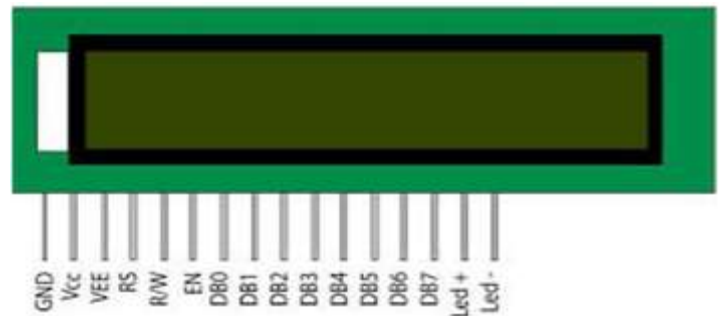

Figure 5, LCD

3.5 SERVO MOTOR :

Servo implies an error sensing feedback control which is utilized to correct the performance of a system. It also requires a generally sophisticated controller, often a dedicated module designed particularly for use with servomotors. Servo motors are DC motors that allows for precise control of angular position. They are actually DC motors whose speed is slowly lowered by the gears. The servo motors usually have a revolution cutoff from 90° to 180°. A few servo motors also have revolution cutoff of 360° or more. But servo motors do not rotate constantly. Their rotation is limited in between the fixed angles.



Figure 6, servo motor

4. SOFTWARE DISCRIPTION

4.1 ARDUINO IDE

- Arduino IDE is an open source software that is mainly used for writing and compiling the code into the Arduino Module.
- It is an official Arduino software, making code compilation too easy that even a common person

with no prior technical knowledge can get their feet wet with the learning process.

- It is easily available for operating systems like MAC, Windows, Linux and runs on the Java Platform that comes with inbuilt functions and commands that play a vital role for debugging, editing and compiling the code in the environment.
- This environment supports both C and C++ languages.



Figure 9. smart dustbin

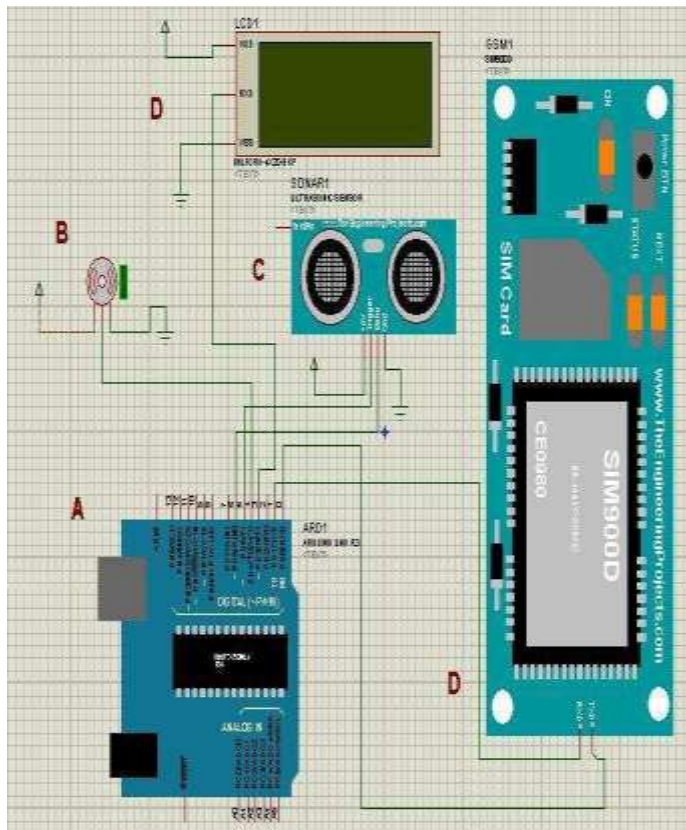

Figure 7 circuit diagram



Figure 8. Hardware Implementation

5. CONCLUSIONS

Various features such as durability, affordability, prevention against damage and maintenance issues are addressed when these smart dustbins are designed. This Smart Dustbin can contribute a lot towards clean and hygienic environment in building a smart city. But since the technology is new in India, proper awareness should be created among the public before it is implemented on a large scale. Otherwise, sensitive devices like sensors might be damaged due to rough action of the users.

6 FUTRURE SCOPE :

1. Solar Panel can be used
2. Virtual Server can be
3. Water Proof circuit design
4. Human Machine Interface
- 6.Line Follower can be used

REFERENCES

[1]. 1.TWINKLE SINHA, 2K.MUGESH KUMAR, 3P.SAISHARAN 1,2,3Information and Telecommunication, SRM University, India
E-mail: twinklesinha511878@gmail.com1, blackpearlson@gmail.com2, saisharan.p@gmail.com

[2]. Swati Sharma*1 & Sarabjit Singh2
*1&2Computer Science & Engineering, Noida International University, Greater Noida, India

[3]. Narayan Sharma, Nirman Singha, Tanmoy Dutta
International Journal of Scientific & Engineering Research, Volume 6, Issue 9, September-

2015 ISSN 2229-5518

- [4]. Monika K A1, Nikitha Rao2, Prapulla S B3,
Shobha G4 Department Computer Science and
Engineering R V College of Engineering, India
monikaarunkumar601@gmail.com1,
nikitharao550@gmail.com
- [5]. Fady E. F. Samann College of Engineering,
Department of Computer and Communication,
Nawroz University, Duhok, Kurdistan Region –
Iraq
- [6]. Kannapiran Selvaraj Research Associate,
Department of ECE, Sriguru Institute of
Technology, Coimbatore, India Email:
skannaprn@gmail.com
- [7]. Dr. Arvind Chakrapani Associate Professor, Department
of ECE, Karpagam College of Engineering, Coimbatore,
India Email: arvichakra@kce.ac.in, arvichakra@gmail.com
- [8]. <https://www.researchgate.net/publication/316700582>
- [9]. <https://www.researchgate.net/publication/320688914>