

SOLAR SEGWAY WITH GRASS CUTTER

N.Harini^{1*}, K. Sandeep Reddy¹, N. Sai Kumar¹, G. Mahesh¹, K. Chandra Shekhar Reddy¹

^{1*}Assistant Professor in Department of Mechanical Engineering, KG Reddy College Of Engineering and Technology, Hyderabad.

¹Student of Mechanical Engineering, KG Reddy College Of Engineering and Technology, Hyderabad.

ABSTRACT:- In this project work, two wheeled and 2 small supporting wheel self-balancing as well as manually balancing Mechanical Segway vehicle is prepared which is also known as a personal transporter Segway. The system is able to operate in transporter mode and robotic mode. The first goal is to maintain stabilization in pitch dynamic. This project focuses on to manufactured Segway without using any type programming & Sensors a state feedback to stabilize system on transporter mode. The system consist of forward and backward movement when the driver operating DPDT switch in transporter mode in order to stabilize body. Small wheel is used so that there is no need of gyroscope for balancing purpose. The aim of this project work is to build up at a very low cost, highly efficient rate and easy to handle and operating also. The tests are performed on mechanical Segway to confirm that Mechanical Segway operating very well and high efficient rate. And adding grass cutter to Segway.

KEY WORDS

Solar panel, DPDT switches, DC motors, cutting blade, Battery, Chain and sprockets.

1. INTRODUCTION

The United States began regulating in 2010, just after the product began to be marketed and a year after a media campaign promoting the Segway HT and its inventor Dean Kamen. At the time this report was written, 40 states and the District of Columbia¹³ had introduced regulations governing the use of HTs on sidewalks, bicycle paths and some roads. The laws vary from state to state, but most define as an —electronic self balancing personal vehicle. Few states also resolute to redefine the phenomenon pedestrian to include —a person using [1]. In fact, the first step toward approval of HTs on sidewalks was adoption of national legislation in June 2010 that legalized their use on sidewalks under federal jurisdiction. This legislation defined the HT as a new vehicle class an two wheel self balanced personal artifice separating it from other motorized vehicles such as scooters. However, Senate Bill 2024, which defines the Segway as an electric transportation device with a stabilized platform between two parallel wheels, gives states and local authorities the power to pass legislation governing the use of at the regional and local level. It approves the use of on sidewalks under federal authority and on private property[2].According to the Bill's wording, the device —employs advances in technology and effectiveness to fully and safely integrate the user with personal transportation;...—enables individuals to travel farther and carry more without use of traditional vehicles, and —promotes gains in utility; minimizes environmental impacts; and facilitates better use of public roadways. This two wheeled balanced aritfice is promoted as a viable transport alternative to other main stream option. Additionally this robot has features suited to adventure, commuting, law enforcement and transportation in

general[4]. Two-wheeled, self balancing systems are studied in many different concepts. They can be considered as robotic platform or as electric vehicle/transporter. Researchers focus on various issues besides the main problem stability. Segway Human Transporter (HT), which is invented by Dean Kamen, is known as the first two-wheeled, self-balancing system in the literature. Flexibility, safety and performance are important due to being commercial product. Segway HT is demonstrated in fig. Also, Segway brings out two wheeled self balancing robotic platform which is called Robotics Mobility Platform (RMP)[5]. Two-wheeled self-balancing systems are mainly classified into two groups as robotic platforms and transporters according to their structure. Robotic platforms are generally constructed as small sized . Fig is that kind of robot. Some of them are driven by an operator while rests are driven autonomously. Operator controlled robots are moved by remote control. This can be achieved by receiving command from a personal computer (PC) via a bluetooth module or a radio receiver. Fully autonomous robots may also have intelligence. These robots generally have camera in order to detect the environment and path planning [6]. As a transporter system, it is driven semi-autonomously by the driver on it. The driver determines the speed and direction of movement of the vehicle by leaning forward and backward. Most of the transporters are combined of standing base and handlebar which make the driver feel comfortable. Also, steering mechanism is generally mounted on the handlebar. However, the vehicle in only consists of a standing base. Steering is provided by shifting center of gravity (COG) of driver. The study discusses the system both as a transporter and as a robotic platform which carries goods. Some studies which are inspired by Segway emphasize creating lightweight and low- cost systems. Their low-costs make them affordable and lightweight make them portable in anywhere. Such two wheeled systems have a wide range of application area. It is clear that the transporter system is used for transportation. On the other hand, robotic system is used for telepresence applications by integrating camera as in. Also, soccer player is made up in. Some robotic systems are designed to carry load. They are used for educational purposes in some studies. Robotic systems generally turn into hybrid systems by combining with necessary components according to the application. Two wheeled robot with arms and waist is designed as a human assistant robot in . The hybrid system in is the robot combined with a manipulator. Two wheeled platform is also used for actuator of a humanoid robot. Moreover, a system which is designed as both ground and aerial robot is studied in [7]. Besides the two-wheeled system, similar studies about one-wheeled (unicycle) self balancing system and balancing on ball systems exist in the literature. As a mechatronic system, it is interested by the academicians. Its stability problem and the interaction among controller algorithm, hardware and software make it popular to study on [8]. Designing controller is the crucial part of the system. The main problem stability is satisfied by the controller. Although this system is highly non-linear, linear controllers are generally applied to the system after linearization because of its low- cost and less complexity. However, non-linear controllers are also attempted in. Most of the studies focus on auto-balancing control. Besides auto-balancing control, controllers are used for tracking control in some studies. Tracking the reference input is achieved here. Many kinds of linear control algorithms are studied on this system. One of the most common controllers is PID type algorithm. This algorithm is easily implemented on the system. Moreover, PD controller is preferred. The reason of not using Integral parameter $-I$ is stated in as its demand of large amount of processing power. Other common controller algorithm is LQR which depends on state feedback controller approach. It is designed and implemented. State feedback controller makes the system robust. Observer is used in order to estimate the states[9] . The essential aim is to stabilize pitch angle in the system. Thus, necessary data must be taken from sensors. The main sensors of the system are

accelerometer and gyroscopes which measure the angle and angular rate of the body, respectively. Most of the studies, use both of these sensors together. However, accelerometer gives noisy data and gyroscope causes drift. Thus, these two sensors are combined with a complementary filter in order to get more accurate data in . Kalman filter is used for sensor fusion during combination of gyroscope and inclinometer . Also, advanced sensor units as inertial measurement units comprising both gyroscope and accelerometer are used . These units give filtered data. The studies which only use accelerometer or gyroscope also exist. Gyroscope is used alone while accelerometer is used. There are also different sensors to measure tilt angle instead of accelerometer in the literature. Inclinometer detects the pitch angle. Also, tilt angle is obtained from infrared range sensors. All processing are carried out by the embedded controller hardware. Microcontrollers are generally preferred in literature because of affordability . Microcontrollers manufactured by Microchip and Atmel are used in many researches. Digital Signal Processing (DSP) board is used for real time applications. Besides DSP, field programmable gate arrays (FPGA) is used as the controller hardware of the systems [10]

2. FLOW DIAGRAM OF THE SYSTEM

Solar Segway with Grass cutter

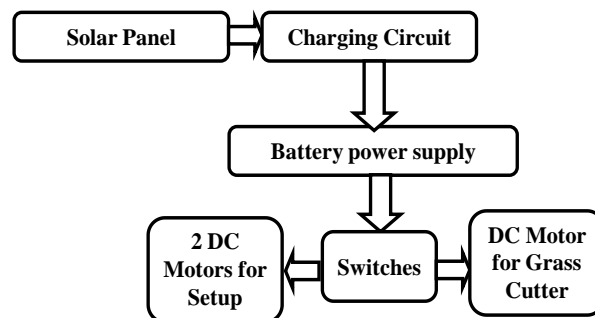

Fig.1. Flow Chart of Solar Segway with Grass cutter

Regulated Power supply



Fig.2.Regulated Power Supply

3. RESULT

Mechanical Segway presents the results of the project. First gets a short discussion on the implementation of the balancing without using any type of programming and sensors. This is followed by some initial driving results and why the vehicle did not behave in satisfactory manner and what was done to improve performance without using programming and sensors. When testing the vehicle for the first time the controller gains were significantly lower as a precaution. This test was mainly performed to see that the system functioned as intended, spinning the wheels in the right and left direction etc. after this was confirmed the first riding test was conducted, and already with this controller the vehicle was drivable. The control strategy with the remaining error serving as a source for speed turned out to be a success and speed control by using DPDT switch forward and backward worked well. Using on/off switch are able to run grass cutting motor and we are able to cut the grass using grass cutter.

4. CONCLUSION

Basically this investigation is successful achieved the objective with the acceptable outcome. The main goal of this project was a build a functional two wheels and one supporting wheels transporter and this goal has been fulfilled. The overall functionality and performance of the vehicle has been evaluated thoroughly by a number of test drives. The vehicle has been tested by a number of different weights. This project is implementing with an idea to find an effective solution to transportation problem.

5. REFERENCES

- [1] D. Küçük, 2010, –Design of Two-Wheeled Twin Rotored Hybrid Robotic Platform||, M.Sc Thesis, Atılım University, Ankara.
- [2] M. Kumaga and T. Ochiai, 2009, –Development of a Robot Balanced on a Ball||, 2009 IEEE International Conference on Robotics and Automation, May 12-17 2009, pp. 4106-4111, Japan.
- [3] K. Pathak, J. Franch and S. K. Agrawal, 2005, –Velocity and Position Control of a Wheeled Inverted Pendulum by Partial Feedback Linearization||, IEEE Transactions on Robotics, Vol. 21, No. 3, June 2005, p. 505-513.
- [4] A. N. K. Nasir, M. A. Ahmad and R. M. T. Raja Ismail, 2010, –The Control of a Highly Nonlinear Two-wheels Balancing Robot: A Comparative Assessment between LQR and PID-PID Control Schemes||, World Academy of Science, Engineering and Technology 70, pp. 227-232.
- [5] C. N. Huang, 2010, –The Development of Self-Balancing Controller for One-Wheeled Vehicles||, Scientific Research Journals of Engineering, Vol 2, pp.212-219.
- [6] M. Burkert, T. Groll, T. Lai, T. McCoy and D. Smith, 2004, –Segway Design Project||, Project Report, Grand Valley State University The Padnos School of Engineering, USA.
- [7] G. Chi, J. Hausbach and B Hunter, 2005, –Segbot||, Senior Design Project, University of Illinois at Urbana-Champaign, USA.
- [8] Motion planning of a balancing robot with threefold sub-task, An endogenous configuration space approach, Krzysztof Tchon.

- [9] K. M. Goher and M. O. Tokhi, 2010, –Development, Modeling and Control of a Novel Design of Two-Wheeled Machines||, Cyber Journals Multidisciplinary Journals in Science and Technology, Journal of Selected Areas in Robotics and Control (JSRC), December Edition.
- [10] Vallius and J. Röning, 2007, –Embedded Object Concept Case Balancing Two-Wheeled Robot, Proceedings of the SPIE, Vol. 6764.
- [11] C. N. Huang, 2010, –The Development of Self-Balancing Controller for One-Wheeled Vehicles||. Scientific Research Journals of Engineering, Vol 2, pp.212-219. Motion planning of a balancing robot with threefold sub-task: An endogenous configuration space approach, Krzysztof Tchon.
- [12] M. Burkert, T. Groll, T. Lai, T. McCoy and D. Smith, 2004, Segway Design Project||, Project