

AUTOMATIC SENSOR OPERATED PNEUMATIC BRAKING SYSTEM

Abubakar R Golandaj, Mohammed Arsalan, Mohamed Jabir P J, Ashfaque

Anjuman Institute of Technology and Management (AITM), Bhatkal

Under the guidance of

Prof. Abdul Muqet

(Associate professor, Department of Mechanical Engineering, AITM Bhatkal)

Abstract -The technology of pneumatics has gained tremendous importance in the field of workplace rationalization and automation from old-fashioned timber works and coal mines to modern machine shops and space robots. It is therefore important that technicians and engineers should have a good knowledge of pneumatic system, air operated valves and accessories. The air is compressed in an air compressor and from the compressor plant the flow medium is transmitted to the pneumatic cylinder through a well laid pipe line system. To maintain optimum efficiency of pneumatic system, it is of vital importance that pressure drop between generation and consumption of compressed air is kept very low.

The aim is to design and develop a control system based on intelligent electronically controlled automotive braking system is called "AUTOMATIC SENSOR OPERATED PNEUMATIC BRAKING SYSTEM". This Braking system is consists of IR transmitter and Receiver circuit, Control Unit, Pneumatic braking system. The IR sensor is used to detect the obstacle. There is any obstacle in the path, the IR sensor senses the obstacle and giving the control signal to the breaking system. The pneumatic braking system is used to brake the system.

Key Words: Infrared Sensor, Receiver, Pneumatic Cylinder, Solenoid Valve, AC Motor, Flow Control Valve and Obstacle.

1. INTRODUCTION

Road accident is most unwanted thing that happens to road user. Sometimes this accident proves to be fatal. The major source of car accident is human error. These accidents are mostly caused by delay of the driver to press the brakes. The basic approach of this paper is to design a system which will prevent such accidents by continuously keeping the record of the distance between two vehicles. In IBS, ultrasonic sensor senses imminent collision with another vehicle, person or obstacle and the microprocessor in the system activate the brakes and it will slow down the vehicle or bring it to stop if needed. This IBS has to be work with ABS (antilock braking system) equipped in vehicle in order to increase control over vehicle while emergency braking. The primary objective of this paper

is to develop a safety car braking system using IR sensor and to design a vehicle with less human attention to the driving.

1.1 Objectives

- To minimize the road accidents.
- To ensure the safety of passengers and vehicle.
- To promote welfare.

2. LITERATURE REVIEW

The aim is to design and develop a control system based on pneumatic braking system of an intelligent electronically controlled automotive braking system. Based on this model, control strategies such as an 'antilock braking system' (ABS) and improved maneuverability via individual wheel braking are to be developed and evaluated.

There have been considerable advances in modern vehicle braking systems in recent years. For example, electronically controlled ABS for emergency braking, electronically controlled hydraulically actuated individual brake-by-wire (BBW) systems for saloon cars and electronically controlled pneumatically actuated systems for heavy goods vehicles. The work of recent years shall form the basis of a system design approach to be implemented. The novelty of the proposed research programmed shall lie in the design and evaluation of control systems for achieving individual wheel motion control facilitated by BBW. In the case of BBW the brake pedal is detached from the hydraulic system and replaced by a 'brake pedal simulator'. The simulator provides an electrical signal for the electronic control system.

Preliminary modeling and simulation work considers a quarter cars initially followed by a natural progression to the half car and full four wheel station cases. The model is to be constructed in modular form thus allowing the replacement / interchange of the various blocks and their associated technologies. Upon completion of the full vehicle braking model, sensitivity analyses will be carried out. Once the preliminary simulation model has been thoroughly benchmarked and existing control system strategies evaluated, an audit of the technology used is to take place and this will provide a basis for comparison of iterative technologies / techniques.

3. PROBLEM STATEMENT

Now-a-days accident prevention is a major sector of research. We are seeing the most of the accidents, occurred due to driver mistake. To avoid that mistake, some arrangements are needed to help driver in critical condition. So, Intelligent Braking System is such type of system which applies brake without the permission of driver by seeing the obstacle in the given path and helps to avoid accidents. Intelligent Braking System is introduced for providing safety and comfort to driver during driving. The main aim of system is avoid damage of life and property.

4. WORKING PRINCIPLE

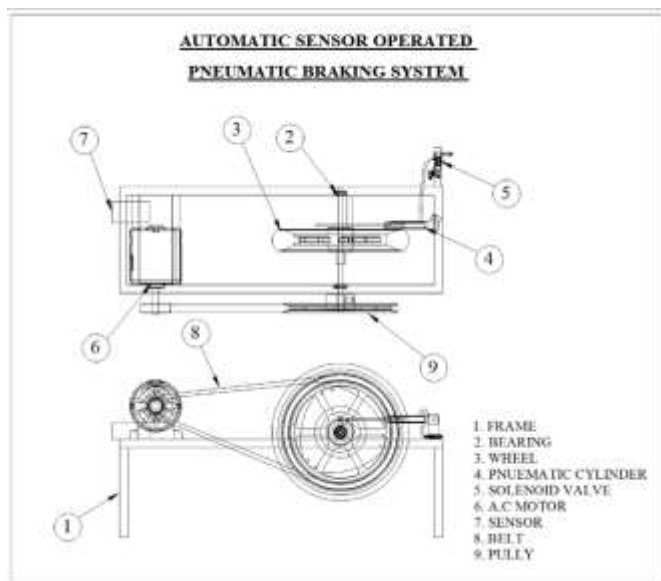

The ultrasonic circuit is to transmit the signal to detect the obstacles. If any obstacle is there in a path, the rays reflected. This reflected rays are received by the receiver circuit is called "ULTRASONIC RECEIVER". The receiver circuit receives the reflected IR rays and giving the control signal to the control circuit. The control circuit is used to activate the solenoid valve. If the solenoid valve is activated, the compressed air passes to the Double Acting Pneumatic Cylinder. The compressed air activate the pneumatic cylinder and moves the piston rod. If the piston moves forward, then the braking arrangement activated. The ac motor and a pulley with belt drive arrangement used for the movement of the wheel. The braking arrangement is used to brake the wheel gradually or suddenly due to the piston movement. The braking speed is varied by adjusting the valve is called "FLOW CONTROL VALVE". In our project, we have to apply this braking arrangement in one wheel as a model. The compressed air drawn from the compressor in our project. The compressed air flow through the Polyurethane tube to the flow control valve.

4.1 LIST OF MATERIAL

Sl. No.	Parts	Qty.	Material
i.	Frame	-	Mild steel
ii.	Pneumatic cylinder	1	EN-8
iii.	Solenoid valve	1	-
iv.	Flow control valve	1	-
v.	Wheel	1	-
vi.	Sensor unit	-	-
vii.	Tube	req	Polyurethane
viii.	Ac motor	1	230v Ac
ix.	Bearing	req	Steel
x.	Belt	1	-
xi.	Pulley	2	CI/MS

5. ADVANTAGES AND DISADVANTAGES

5.1 Advantages

- Brake cost will be less.
- Free from wear adjustment.
- Less power consumption
- Less skill technicians is sufficient to operate.
- It gives simplified very operation.
- Installation is simplified very much.
- To avoid other burnable interactions viz... (Diaphragm) is not used.
- Less time and more profit.

5.2 Disadvantages

- Less distance of sensor
- High maintenance

6. APPLICATIONS

- For automobile application
- Industrial application

7. CONCLUSIONS

This project work has provided us an excellent opportunity and experience, to use our limited knowledge. We gained a lot of practical knowledge regarding, planning, purchasing, assembling and machining while doing this project work. We feel that the project work is a good solution to bridge the gates between the institution and the industries.

We are proud that we have completed the work with the limited time successfully. The AUTOMATIC SENSOR OPERATED PNEUMATIC BRAKING SYSTEM is working with satisfactory conditions. We can able to understand the difficulties in maintaining the tolerances and also the quality. We have done to our ability and skill making maximum use of available facilities.

In conclusion remarks of our project work, let us add a few more lines about our impression project work. Thus we have developed AUTOMATIC SENSOR OPERATED PNEUMATIC BRAKING SYSTEM which helps to design a robot. In this project, we have combined the mechanisms of robotic and monitoring systems using an electronic control units which actually moves and records the instants of the soil report and feeds it back to the control unit.

REFERENCES

1. G.B.S. Narang, "Automobile Engineering", Khanna Publishers, Delhi, 1991, pp 671.
2. William H. Crowse, "Automobile Engineering".
3. Donald. L. Anglin, "Automobile Engineering".
4. Pneumatic Control System----Stroll & Bernaud, Tata Mc Graw Hill Publications, 1999.
5. Pneumatic System----Majumdhara, New Age India International (P) Ltd Publishers, 1997.

BIOGRAPHIES



Abubakar R Golandaj
Dept. of Mechanical Engineering,
AITM Bhatkal.



Mohammed Arsalan
Dept. of Mechanical Engineering,
AITM, Bhatkal.



Mohamed Jabir P J
Dept. of Mechanical Engineering,
AITM, Bhatkal.



Ashfaque
Dept. of Mechanical Engineering,
AITM, Bhatkal.