

# STUDY THE FUNDAMENTAL SURVEY OF SOLAR BASED WATER MANAGEMENT SYSTEM ANALYSIS TECHNIQUE

Sanket Mungale<sup>1</sup>, Kaustubh Mungale<sup>2</sup>, Prasad vashta<sup>3</sup>

<sup>1</sup>PG Student, AMGOI, Kolhapur, Maharashtra, India.

<sup>2</sup>Student, PUNE UNIVERSITY, Kolhapur, Maharashtra, India.

<sup>3</sup>Student, PUNE UNIVERSITY, Kolhapur, Maharashtra, India

\*\*\*

**Abstract** – solar primarily based system water management system it's additional appropriate to water management system and conjointly dry region space it'll be conjointly effective to analysis however the system would shield the water level and conjointly outline some management task. Currently the fish farming this methodology is additional necessary to analysis the fish life in their work how to established this effective work victimization scheme some one quick work on scheme. This project helps farmer to automatically on and off the pump victimization GSM, controls the water level victimization PIC controller. in turn save the electricity victimization star plates. condition level at intervals the soil is measured with the help of detector and looking forward to the detector output. The motor is activate and off victimization PIC microcontroller and thus the standing of motor is shipped to the farmer victimization GSM.

**Key Words:** — solar energy, , types of solar cell, solar energy farming l, solar working ,

**1.INTRODUCTION** In our farm we are able to want to developed star based mostly irrigation system that is additional delight the utilized in our farm .the management to our farm it's conjointly effective than cluster. So most and minimum water level management. In wawing off several state is additional water issue and it's conjointly defective and reliable thus as their the work holik enviorment that is additional work done mistreatment this method and it'll be effective than other task. More farmer which might be issue of water management in day to days work of their farm it'll be reduced an equivalent work from all world farmer. The Soil condition device is used to measure condition at intervals the soil. metric system for Mobile communication (GSM) module is used to supply communication between user and system. It is given Subscriber Identification Module (SIM) of mobile service provider that send Short Message Service (SMS) to the many user. In several country solar power is basic have to be compelled to be used correct work will be done kind solar power that is very reliable and cost accounting is effective. Indian country is world third largest solar power manufacturing .many state like Maharashtra ,it is quickest than additional reliable ways that.

## 2. LITREATURE REVIEW:

As our data purpose of read varied folks and electrical board corporation that is nice for exploitation this alternative

energy .more alternative energy is on the market In our country .so government conjointly support to the alternative energy .it will be effective as before long as potential to try to to some a lot of.

As my survey star based mostly sensible irrigation system that is vital task to our day to day life .it is having a lot of economical and higher system output for folks, whenever this work is best system analysis to public .so once our want is made at the tip stage thus me ways that it's higher output.

## 3. OBJECTIVE:

1) it's the bottom and reasonable.

2) it's economical and transportable meaning we will place this circuit at anyplace simply.

3) Maintenance price is low & easy to use.

## 4. PORPOSED WORK :

In this system that is additionally required the essential task of farmer to manage the water level in their revier and tank. however exploitation this method deep irrigation this may be reduced the loss of system failure as shortly as potential . in fish farming this conjointly necessary day to day life management . therefore this method mechanically manited therefore our system best answer to farmer that is dry soil level simply caputred and hand based mostly sensible result.so this method is a lot of correct and stable.

Mobile communication (GSM) module is used to supply communication between user and system. It is given Subscriber Identification Module (SIM) of mobile service provider that send Short Message Service (SMS) to the many user. In several country solar power is basic have to be compelled to be used correct work will be done kind solar power that is very reliable and cost accounting is effective.

Indian country is world third largest solar power manufacturing .many state like Maharashtra ,it is quickest than additional reliable ways that.

5.FLOW CHART:

START THE SYSTEM ON THIS FLOW

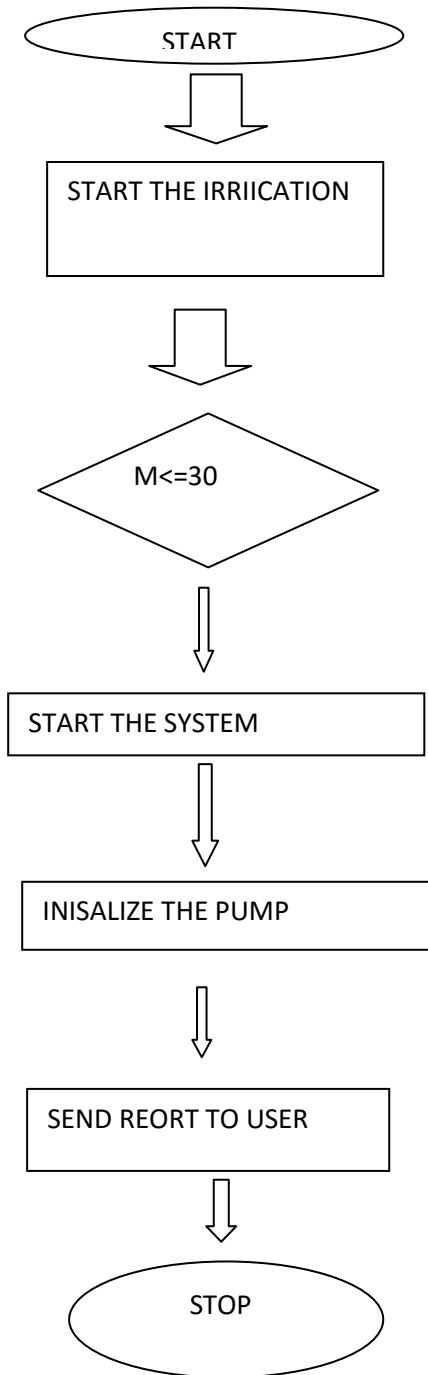

STOP WORKING

6. BLOCK DIAGRAM

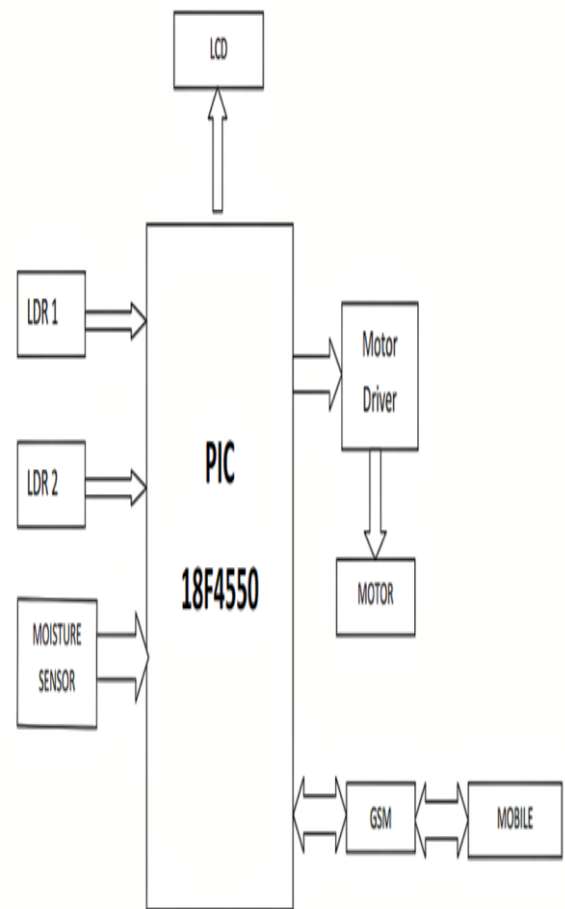

Fig.2.1.Block diagram of smart irrigation system

?? Working

Assuming the examples of under standing point of view.

7. SYSTEM WORKING

Soil wet device senses the wet level and provides its output to the PIC. PIC acknowledges the wet level and consistent with it, provides signal to motor. As per the signal coming back from PIC motor is turned ON or OFF. The standing of motor is additionally recognized by PIC and same standing is given to the GSM module. Then GSM module send this standing to the user. All this method is showed by the 16\*2 liquid crystal display .

**1 Soil wetness Sensor:** The Soil wet device uses capacitance to measure material permittivity of the peripheral medium. In soil, material permittivity is a perform of the water content. The device creates a voltage proportional to the material permittivity, and therefore the water content of the soil

**2.f PIC 18F4550 managementler:** it's advances controller which might be wont to control the info send the data to user to gsm module.

**3.Motor Driver:** primarily Motor Driver is used to drive the motor. In L293D we have a tendency to area unit able to drive a pair of motors exploitation single driver, as a results of L293D has 2 channels. In our project , once condition level goes down at that time condition detector send the result to PIC . Then PIC offers instruction to driver and then driver drives the motor. i.e. ON or OFF the motor.

**4. Motor:**A DC motor in straightforward words might be a tool that converts current (direct current system) into energy. it's of vital importance for the trade recently, and is equally necessary for engineers to appear into the rule of DC motor in details that has been mentioned throughout this text. In order to understand the operational principle of DC motor we've a bent to need to first look into its constructional feature.

**5. world System For Mobile communication(GSM:** A GSM equipment duly interfaced to the Mc through the extent shifter IC Max232. The SIM card mounted GSM equipment upon receiving digit command by SMS from any transportable send that information to the Mc through serial communication. whereas the program is dead, the GSM equipment receives command 'STOP' to develop academic degree output at the Mc, the contact purpose of that square measure accustomed disable the control.

The command thus sent by the user depends on academic degree intimation received by him through the GSM equipment 'ALERT' a programmed message providing the input is driven low. the full operation is showed over 16x2 digital display .

**6. Mobile:** transportable is used at receiving end for communication purpose. Message sent by the GSM module is viewed on this device

**7. liquid Display:** it will be show the output on the screen that is digitally displayed.

**8:** in additional hardware we can used max232 which is serial communication and send the data .

**9. Power** Supply which can be used to system management

**10. Software Used:**1. Proteus 8.0,2. MPLAB X IDE

**8. RESULT:**

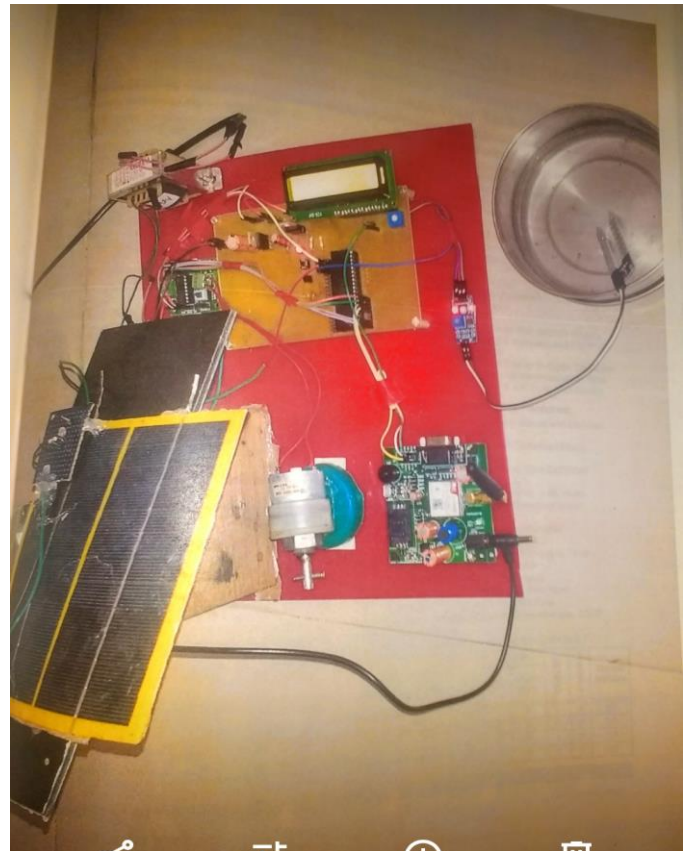

**8. CONCLUSION**

. From victimisation this method it'll be effective ethical support and most clean up framing work is additionally scale back therefore future would like it's a lot of vital the water management task to all or any farmer at significant weight. therefore star based mostly system it's a lot of sturdy add farming

**9. Future scope:**

Our project will be makeshift by adding a Web scaper which may predict the weather and water the plants/crops consequently. If rain is forecasted, less water is unchained for the plants.

Also, a GSM module will be enclosed so the user will management the system via good phone. A meter will be put in to estimate the quantity of water used for irrigation and therefore giving a price estimation. A coil valve will be used for varied the amount of water flow. what is more, Wireless sensors also can be used

**10. Applications:**

It is conjointly used for fish farming to cut back the wastage of water.in dry region space it'll be effective and various work is finished for farming vision folks.

**REFERENCES**

- 1] star based mostly water management system analysis work icced 2012
- 2] star management system vevo laboratory India 2013
- 3] ndian star association 2014 conferences in metropolis 2015
- 4] wikipediya 2015 soalr energy revolution management conferences 2016
- 5] hitachi corporation world alternative energy conferences 2017
- 6] maharashtra government has 2016 star management conferences 2018
- 7] divya Mahratti news paper alternative energy resolution analysis 2013
- 8] in U.S.A. energy is 2016 @ amricam conferences lam biss U.S. .
- 9] Delhi corporation star management system pilot project system @ ram jadav , and kishan ware.
- 10] unity and wind energy corporation India decision conferences 2015
- 11] indian oil energy sill development authority conferences 2012
- 12] maharashtra energy mahamandal restricted 2013 review press conferences