

# Analysis of Wobble Bush Plate acting on Axial Piston Pump

Prof. Sachin Wangikar<sup>1</sup>, Prof. Ganapati Kapashi<sup>2</sup>, Prof. Rajashekhar M S<sup>3</sup>

<sup>1,2,3</sup>Professor, Mechanical Engineering of Shaikh College of Engineering and Technology, Belagavi Karnataka, India

\*\*\*

**Abstract** - Wobble bush component in axial plunger pump is in direct contact with the pistons arranged circularly in the cylinder. Wobble bush makes the contact with pistons at certain angle to give a stroke which in turn displaces the volume of fluid to discharge valve. Wobble has to push the piston to displace the volume of fluid against the extreme high pressure in the hydraulic line. The details of the wobble bush are included in the paper indicating modeling, Meshing and stress behavior of the component. Stress and Strain Analysis is performed on the component and the results are found to be with safe limits.

- The Figure 1.1 shows the oil is sucked in cylinder port by gear pump and leaves out the discharge port by the stroke of pistons, which pushes the oil with pressure and velocity.

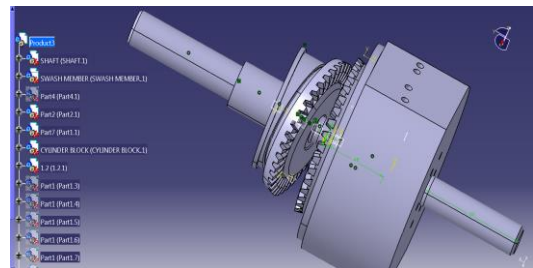

Fig:1.1 Suction in Cylinder port

**Key Words:** Wobble Bush, Axial Plunger.

## 1. INTRODUCTION

Axial plunger pumps are most used in fluid power systems such as hydraulic presses, process plant machinery and various other industry such as construction machinery, automotive industry and aerospace industry. A wobble plate is a device used in mechanical engineering to translate the motion of a rotating shaft into reciprocating motion. One most common type of wobble plate design or swash plate as shown in figure above where the piston are embodied in slippery pads which in turn embodies in swash plate with some clearances. So as the swash plate rotates and its inclination with certain angle produces high end and low end of swash plate, which in turn produces the stroke for pistons. But in our case the pistons are not embodied in wobble plate, they are arranged circularly in cylinder and the mechanism to provide the stroke for pistons is quite different compared to many common axial pistons pumps.

- b) **The stroke of piston (drive end)** - is achieved by wobbling mechanism or nutating gear mechanism where one bevel which is fixed at the cylinder hub is been meshed with rotating bevel gear and the wobble plate bush is shrink fitted to rotating bevel gear, when the rotating bevel gear is rotated meshing with fixed bevel gear, it produces wobbling motion, where pistons comes in contact with wobble plate bush and the piston are pushed by wobble plate bush to produce the stroke of piston and the oil is forced at discharge valve.

### 1.1 Description of Axial Plunger Pump

**Working principle can be divided into two main mechanisms.**

- Suction of oil
- Wobbling mechanism to give stroke

a) **Suction of oil** -The axial plunger pump at inlet section consists of spur gears which are mounted on shaft. The suction of oil is done by gears at a pressure around 40 Psi which causes the valve seat at inlet port of cylinder block to move from its position and the oil is sucked in the cylinder port and valve seat of cylinder port moves back to its position preventing the back flow of oil.

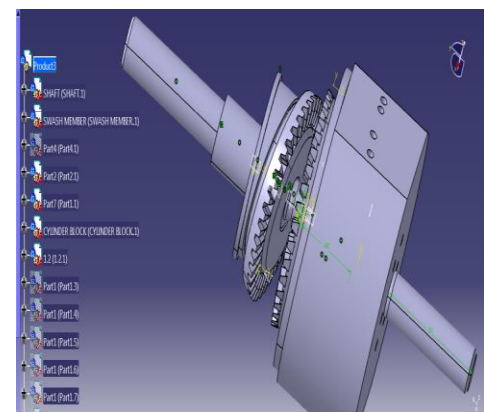

Fig:1.2 Wobbling mechanism to give stroke

## 1.2 Wobble Member

The wobble member is tapered to 13 degree to form high end and low end, to the in turn makes the front hub of swash member on inclined surface making it eccentric to give the 13 degree inclination and 13mm stroke as shown in figure below

- The figure 1.3 shows the eccentricity is made to swash member to give the stroke on pistons.

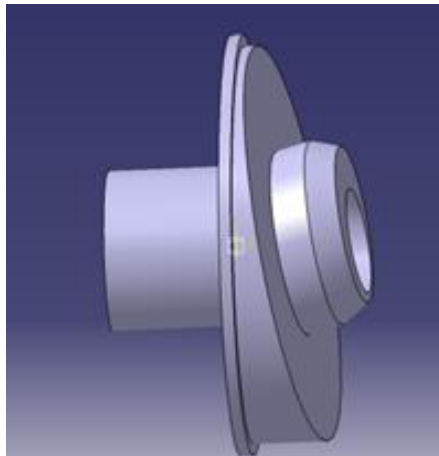

Fig:1.3 eccentricity of swash member

## 2) Analysis of Wobble Bush

### 2.1 Meshed model of the wobble plate

Meshing is carried out on the wobble plate. The fine mesh is carried out on the loading plate using tetrahedron element for meshing, as it has one hole on it, where the area suddenly reduces and there are more chances that the component may fail in this region. The entire part of the system is provided with fine mesh, using the same tetrahedron element.



Fig:2.1 Meshed Wobble Bush Plate

### 2.2 Stress analysis of Wobble Bush Plate

After analysis it is observed that -

- When there is perfect contact the width  $b$  and  $l$  makes a larger area of contact and the load is taken care by larger area so the stresses generated are lesser
- Due to larger area of contact the depth of penetration of contact due to forces applied is less and there is no pitting or scoring on the surfaces
- When there is mismatch contact the width  $b$  increases from 0.127 to 0.211 but the length of contact reduces drastically from 9.47 to 0.347, which in turn reduces the contact area from 2.4 mm<sup>2</sup> to 1.46 mm<sup>2</sup>. Hence the same amount of force generates the extreme high pressure on wobble bush causing high stress zone and deformation and even the depth of penetration in  $z$  direction also increases with same amount of forces from ( $z = 3b = 0.381\text{mm}$  to  $0.633\text{mm}$ )
- That is the depth of contact is almost doubled for same forces causing the pitting and scoring on new component of wobble bush while performance testing

Comparison of all stresses generated when there is perfect contact and mismatch contact by graphs.

- Graph for perfect contact where stresses are plotted against the depth distance ( $z$ )

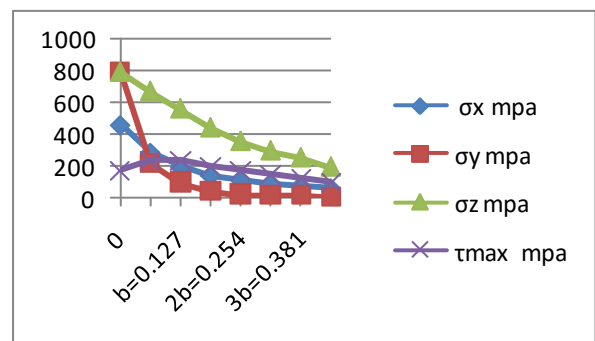

Chart -2.1: Perfect Contact of Piston and Wobble Bush

- Graph for mismatch contact where stresses are plotted against the depth distance ( $z$ )

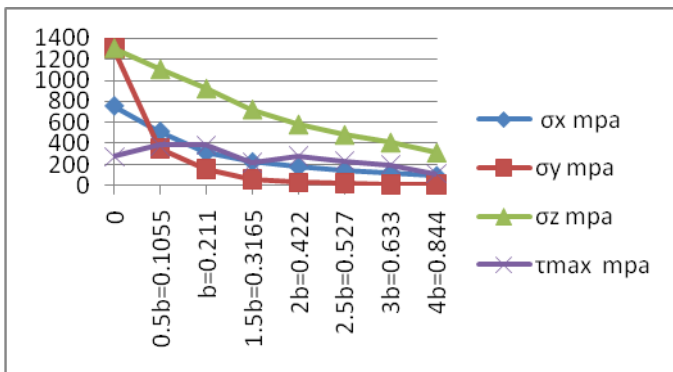

Chart -2.2: Mismatch Contact of Piston and Wobble Bush

Comparison of perfect contact results of theoretical with software results.

- Figure 2.2 shows the von mises stresses on wobble bush

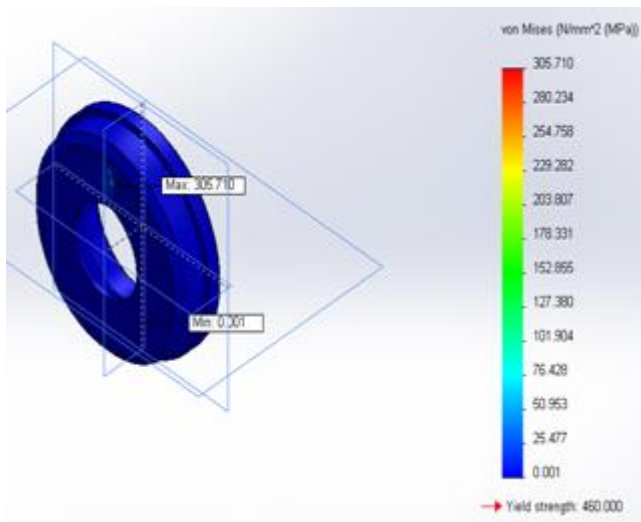

Fig:2.2 von mises stresses on wobble bush

The stresses in Z direction are –

- Maximum stress is at the node 1796 is 305.76 Mpa
- Minimum stress is at node 40638 is 0.001145 Mpa
- Theoretical stresses in Z direction – 356.35 Mpa.

Figure 2.3 shows the strain in wobble bush

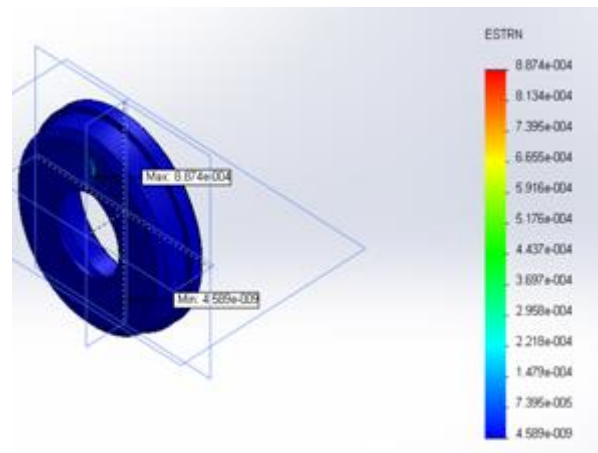

Fig2.3 strain in wobble bush

- Maximum strain in z direction is - 0.00088736

### 3. CONCLUSIONS

The study of Wobble bush plate was taken into consideration when mounted on axial plunger pump for two cases.

- 1) Mismatch Contact
- 2) Perfect Contact

It was observed in both the cases that the stresses acting on the wobble bush plate are within the safe limits.

### REFERENCES

- [1] Molham Chikhalsouk1, Concordia University, Montreal, CANADA, “Modeling And Simulation Swash Plate Pump Response Characteristics in Load Sensing And Pressure Compensated Hydraulic System”, IJMER | ISSN: 2249-6645, volume 7, Issue 08, 2017 .
- [2] Guangjun Liu 1, Zhaocheng Zhou, Shanghai, China;” **Multidisciplinary Design Optimization of a Swash-Plate Axial Piston Pump** Appl. Sci. **2016**, **6**, 399.
- [3] F. Fornarelli, A. Lippolis, Roma A computational model of axial piston swash plate Pumps , Published by Elsevier Ltd. 72nd Conference of the Italian Thermal Machines Engineering Association, ATI2017, 6-8 September 2017, Lecce, Italy.

### BIOGRAPHIES



Currently working as Asst.Prof.at Shaikh College of Engineering & Technology, Belagavi, Karnataka, India



Currently working as Asst.Prof.at  
Shaikh College of Engineering &  
Technology,  
Belagavi,Karnataka,India



Currently working as Asst.Prof.at  
Shaikh College of Engineering &  
Technology,  
Belagavi,Karnataka,India