

# Evaluation of G+ 10 Structure for seismic performance under base isolation

*Sahil Eknath Laste<sup>1</sup>, BE, Dept of Civil Engineering, Dilkap Research institute of engineering and management studies*

*Sahil Ashok More<sup>2</sup>, BE, Dept of Civil Engineering, Dilkap Research institute of engineering and management studies*

*Kunal Kashinath Chipte<sup>3</sup>, BE, Dept of Civil Engineering, Dilkap Research institute of engineering and management studies*

*Nikhil Vitthal Chawan<sup>4</sup>, BE, Dept of Civil Engineering, Dilkap Research institute of engineering and management studies*

*Reshma Shaikh<sup>5</sup>, Assistant Professor, Dept of Civil Engineering, Dilkap Research institute of engineering and management studies*

**Abstract:** A large population of the world lives across the regions of seismic hazards, due to which a considerable amount of damage has been observed after each and every earthquake incident. Earthquake also causes loss of property as well as loss or injury to the living beings. And, sudden collapse of building is observed because of the several intensities and frequencies of earthquake. Hence, to counteract the effect of the seismic hazards base isolation is one of the best technique against the earthquake. It is the technique which isolates the superstructure from substructure, due to which this technique is named as "base isolation". Base isolation consist the various system which are to be installed under the superstructure such as High damping rubber bearing (HDRB), Elastomeric rubber bearing (ERB), Lead rubber bearing (LRB), Friction pendulum system (FPS). A bearing is a small part of structure but, the importance of this part is inversely proportion to its size. This is so because the entire load of the structure as well as the energy exerted by earthquake waves in transmitted and absorbed by this part only. Hence, the various parameters in its design should be given the great importance as any misbehaviour in its performance due to its poor design will lead to the collapse of structure as whole. In the present study, we have considered the elastomeric rubber bearing and lead rubber bearing as a base isolation technique. We have designed both the bearings considering two different loads i.e. internal column load and external column load referring is code as well as reference books for design procedure for various design standards. Design parameters such as rubber thickness and bearing pad size are common in both the bearings except that lead core diameter in lead rubber bearing is unique design parameter. Nonlinear modal time history analysis was carried out on three different G+10 building models such as fixed base and isolated base in ETABS 2016 software.

The aim of the study:-

1. Evaluation of the building structure with or without isolators.
2. Comparing the building structures using time history analysis using software ETABS 2016.
3. Comparing the structures considering three important parameters which includes storey drift, storey displacement and base shear.

## INTRODUCTION

Quakes are unexpected wonders if the structure is situated in seismic zones. The auxiliary architect needs to venture in order to spare lives and cause insignificant harm to the structures in the midst of seismic tremor. The ongoing improvement for hostile to seismic plans is base detachment, which may not decrease the ground development but rather would help in keeping the effect of ground development to its negligible broaden.

## 1.2 BASE ISOLATION

### 1.2.1 What is base isolation?

Base isolation is a cutting edge technique in which the structure (superstructure) is isolated from the base (establishment or substructure) by presenting a suspension framework between the base and the primary structure Base disengagement framework is the often embraced seismic tremor framework. It lessens the impact of ground movement and in this way prompts invalidate the impact of seismic tremor to on the structure. Base disengagement has turned out to be well known in most recent few decades in its executions in structures and scaffolds. Base separation has turned into a customary idea for basic structure of structures and extensions in high hazard territories. Many are as a rule previously built and many are under development.

### 1.2.4 PRINCIPLE OF BASE ISOLATION

The essential guideline behind base isolation is that the reaction of the structure or a structure is adjusted to such an extent that the ground underneath is fit for moving without transmitting insignificant or no movement to the structure above. A total division is conceivable just in a perfect framework. In a true situation, it is important to have a vertical help to exchange the vertical burdens to the base.

The general removal of ground and the structure is zero for a superbly unbending, zero period structure, since the increasing speed actuated in the structure is same as that of ground movement. Though in a perfect adaptable structure, there is no speeding up prompted in the structure, in this way relative displacement of the structure will be equivalent to the ground displacement.

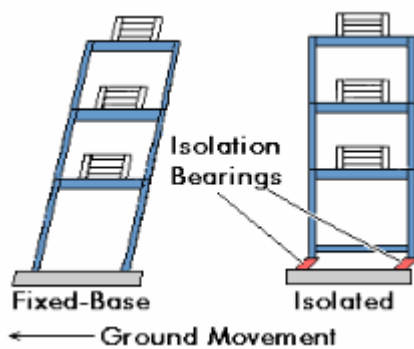

### 1.2.6 GOALS

A high extent of the world is exposed to seismic tremors and society expects that auxiliary specialists will structure structures with the goal that they can endure the impacts of these quakes. Concerning all the heap cases experienced in the plan procedure, for example, gravity and wind, should work to meet a solitary essential condition: CAPACITY > DEMAND. Tremors occur and are wild. Thus, in that sense, we need to acknowledge the interest and ensure the limit surpasses it. The seismic tremor causes powers relative to the result of the structure mass and the quake ground increasing speeds. As the ground increasing velocities expands, the quality of the structure, the limit, must be expanded to maintain a strategic distance from basic harm. Be that as it may, it isn't reasonable to keep on expanding the quality of the structure indefinitely. In high seismic zones the increasing speeds causing powers in the

structure may surpass one or even multiple times the quickening because of gravity, g. It is anything but difficult to picture the quality required for this dimension of burden - solidarity to oppose 1 g methods than the structure could oppose gravity connected sideways, which implies that the structure could be tipped on its side and held even without harm. Planning for this dimension of solidarity isn't simple, nor modest. Along these lines, most codes enable architects to utilize pliability to accomplish the limit. Flexibility is an idea of enabling the basic components to misshape past their versatile farthest point in a controlled way (Figure 1.8). Past this utmost, the basic components mollify and the removals increment with just a little increment in power. As far as possible is the heap point up to which the impacts of burdens are non-changeless; that is, the point at which the heap is expelled the material comes back to its underlying condition. A plan rationality concentrated on limit prompts a decision of;

- Continue to build the flexible quality. This is costly and for structures prompts higher floor increasing velocities. Relief of auxiliary harm by further fortifying may make more harm the substance than would happen in a structure with less quality.
- Limit the flexible quality and detail for pliability. This methodology acknowledges harm to auxiliary segments, which may not be repairable.
- Base disconnection adopts the contrary strategy, it endeavors to decrease the interest as opposed to build the limit. We can't control the quake itself however we can adjust the interest it makes on the structure by anticipating the movements being transmitted from the establishment into the structure above.

Along these lines, the essential motivation to utilize detachment is to relieve seismic tremor impacts. Normally, there is an expense related with segregation thus it possibly bodes well to utilize it when the advantages surpass this expense. What's more, obviously, the money saving advantage proportion must be more appealing than that accessible from elective proportions of giving seismic tremor opposition.

These days Base Isolation is the most amazing asset of the seismic tremor designing relating to the latent basic vibration control advances. It is intended to empower a structure or non-building structure to endure a

conceivably pulverizing seismic effect through an appropriate introductory plan or consequent changes. Now and again, utilization of base seclusion can raise both a structure's seismic exhibition and its seismic maintainability extensively.

**Types of Base Isolators**

Following are different types of bearings used has isolation technique.

1. Laminated Rubber (Elastomeric) Bearing.
2. High Damping Rubber (HDR) Bearing
3. Lead Rubber Bearing (LRB).
4. Friction Pendulum (FPS) System.

**Laminated Rubber (Elastomeric) Bearing:**

It is made out of exchanging layers of elastic that give adaptability and steel strengthening plates that give vertex al load-conveying limit. At the top and base of these layers are steel overlaid plates that appropriate the vertical loads and exchange the shear power to the interior elastic layer.

**High Damping Rubber (HDR) Bearing:**

It is like elastomeric heading where the elastomer utilized (either characteristic or engineered elastic) gives a lot of damping.

**Lead Rubber Bearing (LRB)**

It is shaped of a lead plug compel fitted into a pre-framed gap in a low damping elastomeric bearing or lead can be poured having immaculateness 99 %. The lead centre gives unbending nature under administration burdens and vitality scattering under high sidelong loads. This bearing gives a flexible re-establishing power and furthermore, by determination of the proper size of lead plug, produces required measure of damping.

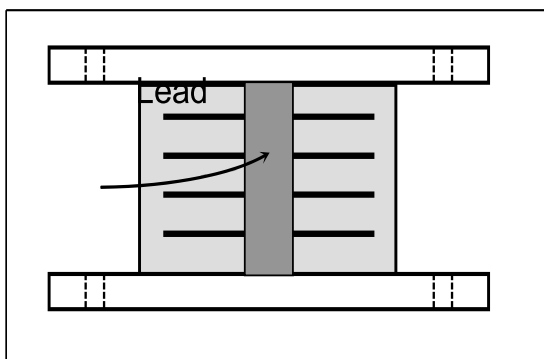

Fig.2 Lead rubber bearing

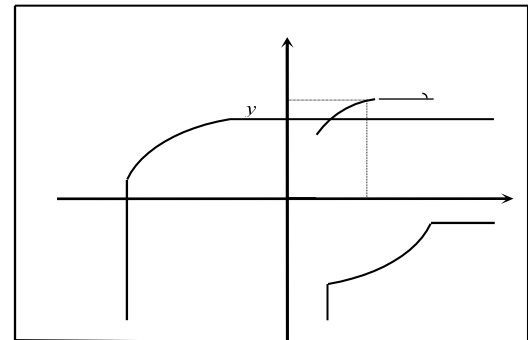

Fig.3 Idealized force-displacement (Hysteresis) Loop of Lead Rubber Bearing

**Friction Pendulum System (FPS):**

Although a number of curved shapes are possible, the only curved sliding which has been extensively used is the one, in which the sliding surface is spherical in shape. It is termed as Friction Pendulum System (FPS). The FPS bearing allows the supported structure to return to its original position, rather than a flat sliding surface, thereby conquering the problem of re-centering.

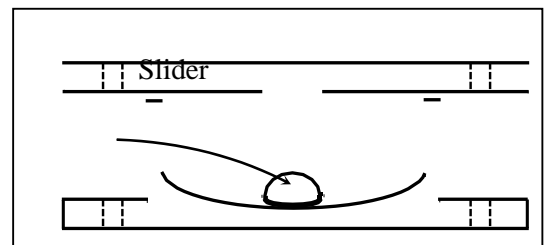

Fig. 4 Friction Pendulum System

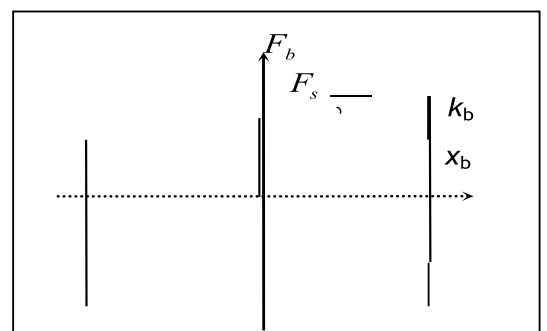

Fig.5 Idealized force-displacement (Hysteresis) Loop of Friction pendulum System

**Literature Review:**

**Review of Literature is divided into two parts:**

Software Literature:

**Omkar Sonawane** :- He played out the examination to analyse the viability of base disengagement in standard and unpredictable multi-storied structures. For this he considered 15 storied R.C outline building and Time History Analysis is completed utilizing ETABS programming adaptation 2013. The Lead Rubber Bearing (LRB) is structured by considering most extreme gravity load coming at the base and the equivalent has been utilized enemy examination. The outcomes got from this examination are looked at in the terms of timeframe ,base shear, story uprooting and story increasing speed. Timeframe for the based confined structure are higher than that of the fixed base structure. Due the nearness of the isolator, base shear and story increasing speed are fundamentally lessen toward every path ( X and Y course) when contrasted with fixed base structure.

**Vinodkumar Parma**:- He did the research on effects of base isolation in multi storied RC irregular building using time history analysis. He used the E Tabs software for the analysis with lead rubber isolator according to UBC 97 code. He compared the response of building such as time period and base shear for 15 storied RC plan and vertical irregular buildings with and without base isolation by considering the time history analysis using earthquake data. He research concluded that time period increases because of use lead rubber isolator which increases the flexibility at the base levels. The increase in time period was seen more in irregular base isolated building as compared to regular base isolated building. They gave higher efficiency in decreasing the base shear as compared to fixed base building. And the reduction seen was more in vertical base isolated irregular building as compared to plan irregular base isolated building.

**Analytical Study**

**Manasa M S**:- He made the examination of execution of lead elastic bearing as a base isolator. He assessed the execution of lead elastic bearing amid seismic tremor by the limited component displaying and non direct examination in ANSYS workbench 17.0 in the investigation. He contrasted the lead elastic bearing and covered elastic bearing. He through his assessment passes on that execution of lead elastic bearing is superior to covered elastic bearing and furthermore the higher vitality

dissemination ability of lead elastic bearing is because of the plastic twisting of lead center which distorts even under little shear pressure which makes it appropriate in solid tremor locale.

**N.KRISHNA RAJU** Design of Bridges:- The design of bridges by Krishna Raju helped us with the design of elastomeric bearings with required parameters as per IRC:83-1987 PART 2 and IS:1076<sup>5</sup>. The use of elastomeric bearing is preferred to metallic bearings which are expensive in initial cost and maintenance. Elastomeric bearings occupy a smaller space, and are easy to maintain and also to replace when damaged. Chloroprene rubber termed as neoprene is the most commonly used type of elastomer in bridge bearings.

**Details of Case Study**

**Building Table 1:**

Building Details	
Grade of Concrete	M30 & M25
Steel Grade	Fe415 & MG250
Floor to Floor height	3.0m
Slab thickness	200mm
Size of Square Columns	300x600mm
Size of Beams	450x500mm
Live load on floor	3kN/m <sup>2</sup>
Floor Finish Load	1.5kN/m <sup>2</sup>
Site located in Seismic zone V	Z = 0.36
Importance factor	1

**Properties of Materials**

**Concrete:**

Grade of concrete= M30& m20  
 Mass Weight= 2.5 KN  
 Damping coefficient= 0.05

**Design of Isolator:**

ELASTOMERIC BEARING DESIGN

Load on External Column= *N* KN  
 Rotation: - *N* radians  
 Grade: - M30  
 Creep: -  $6 \times 10^{-4}$

Solution:-

1. Selection of bearing pad dimensions

Maximum vertical load on bearing =  $N_{max}$  KN  
 (From IRC Part -II-1987)

Minimum vertical load =  $N_{min}$  KN  
 From Table:- IRC83-Part II

$$\text{Load Area} = A_2 = mm^2$$

CLAUSE 307.1 of IRC 21

$$\text{Allowable contact pressure} = 0.25 f_c \sqrt{\frac{A_1}{A_2}}$$

As per IRC21  $\left(\frac{A_1}{A_2}\right) =$

$A_1$  = Concrete bed block area over pier

$A_2$  = Elastomeric pad area

$$\text{Effective Bearing Area Required} = \left(\frac{N_{max}}{\sigma_c}\right)$$

From Table 15.2 IRC83, find  
 $h_i, h_e, h_s, \text{Side Covering}$

Adopt laminates with the internal layers

Total thickness of elastomeric pad

$$h_a = (2h_e + 3h_s + 2h_i)$$

Shape Factor = r

$$\left[ \frac{\text{Loaded Surface Area Of An Internal Layer of ERB}}{\text{Surface Area Free To bulge}} \right]$$

$$\begin{aligned} \text{SHEAR STRAIN DUE TO CREEP} \\ &= (0.5 \times \text{Creep}) \\ &= 3 \times 10^{-4} \end{aligned}$$

$$\gamma_d = \left[ \frac{\text{Shear strain due to creep}}{\text{Shrinkage and temperature}} \right] + [\text{Shear strain due to longitudinal force}]$$

MAXIMUM PERMISSIBLE ANGLE OF ROTATION OF A SINGLE INTERNAL LAYER

Assuming  $\sigma_{max} = 10 \text{ N/mm}^2$

$$\sigma_{bi.max} = \left[ \frac{0.5 \sigma_{mhi}}{b.S^2} \right]$$

Permissible rotation =  $\alpha_d = \beta n \alpha_{bi.max}$

$$\text{Where, } \beta = \frac{\sigma_m}{\sigma_{m.max}}$$

N = Number of internal elastomeric layer

FRICTION

Shear Strain Computed = x  
 Under Critical Loading Condition

$$\text{Shear strain} \leq 0.2 + 0.1 \sigma_m$$

It should satisfies the criterion that

$$10 \text{ N/mm}^2 \geq \sigma_m \geq 2 \text{ N/mm}^2$$

TOTAL SHEAR STRESS

$$\text{Shear Stress due to compression} = 1.5 \left( \frac{\sigma_m}{s} \right)$$

SHEAR STRESS DUE TO HORIZONTAL DEFORMATION

$\tau_R = \gamma_D \dots$  As per computation due to translation

$$\text{Shear Stress due to rotation} = 0.5 \left( \frac{b}{h_i} \right)^2 \alpha b_i$$

Total stress = SS due to rotation + SS due to compression + SS due to translation.

**Design of Lead Rubber**

(a) For rubber bearing

$$K_H = \left[ \frac{2\pi}{T_{eff}} \right]^2 \times \frac{W_i}{g} =$$

5. First estimation of design displacement:

$$D_{bd} = \frac{g \times C_v \times T_{eff}}{4\pi^2 \times B} =$$

Assume total rubber thickness  $t_r = 200mm$  with shear modulus 0.4Mpa for external column and 1.0 Mpa for internal column.

$$K_H^E = \frac{G_I \times A}{t_r} =$$

$$\text{So, } A = \frac{t_r \times K_H^I}{G_I} =$$

Hence, diameter of rubber bearing

$$\phi = \sqrt{\frac{4 \times A}{\pi}} =$$

6. Actual bearing stiffness

$$K_H^E = \frac{G_I \times I}{T_r} = \frac{0.4 \times 0.28}{0.2} =$$

$$K_H^I = \frac{G_E \times I}{T_r} = \frac{1 \times 0.283}{0.2} =$$

7. Composite stiffness

$$K_H = \text{No of external column} \times K_H^E + \text{No of internal column} \times K_H^I$$

8. Allowance for torsion

$$D_T = \left[ D \left( 1 + Y_{b^{2+d^2}}^{12e} \right) \right] =$$

Here,

b=dimension of shorter side

y=half of longer dimension=  $\frac{d}{2}$

d=dimension of longer side

e=0.05 times of longer direction

Torsional stiffness ( $K_\theta$ )=

Additional displacement

$$\theta_y = \frac{K_H}{K_Q} \times D \times e \times Y$$

9. Elastic base shear

$$V_S = \frac{K_H \times D_D}{R_W}$$

10. Bearing details

Assume vertical frequency  $f_v = 10Hz$

$$\text{Then, } 6S^2 = \frac{FV^2}{F^2H}$$

To calculate the vertical frequency and the buckling load for bearing, we use small strain shear modulus for each rubber such as 20%.

So,

$$G_{0.2}^E = 0.7Mpa \text{ and } G_{0.2}^I = 1.4Mpa$$

$$E_C = \frac{6GS^2K}{6GS^2+K} \text{ where } K=2000Mpa$$

Therefore,

$$S = \frac{\phi}{4T}$$

(B) For lead plug bearing

12. Design displacement

$$D_D = \frac{9.81}{4\pi^2} \times \frac{CV.T}{B}$$

13. The required stiffness to provide a period of 2.5sec

14. The global energy dissipated per cycle

$$W_D = 2\pi K_{eff} \cdot D^2 \times \beta_{eff}$$

The relationship of these quantities to the two lead plug bearing parameters Q and  $K_r$  is

$$K_{eff} = K_r + \frac{Q}{D}$$

And,  $W_D = 4Q(D - D_y)$

Where,

$$\text{Where, } D_y = \frac{Q}{K_1 - K_2}$$

And as an approximate rule of thumb, we take

$$K_1 = 10K_2.$$

If we neglect  $D_y$ , we have a first approximate for Q

$$Q = \frac{W_D}{4(D - D_y)} = \frac{W_D}{4D}$$

$$\text{So, } K_2 = K_{eff} - \frac{Q}{D}$$

$$\text{And, } D_Y = \frac{Q}{K_1 - K_2} = \frac{Q}{9K_2}$$

Correcting the first estimation of Q for  $D_Y$  gives

$$Q = \frac{W_D}{4(D - D^4)}$$

$$A_{pb} = \frac{Q}{F_y}$$

Total rubber stiffness ( $K_r = K_H - \frac{Q}{D_D}$ )

And,

$$K_{eff} = 16 \times K_r + \frac{W_D}{D_D}$$

$$W_D = 4 \times Q(D_D - D_Y)$$

15. Vertical stiffness of LRB

Vertical stiffness of rubber bearing is given by

$$K_V = \frac{A \times E_C}{T_r}$$

$$E_C = 6GS^2$$

$$E_C^E = 6G^E S^2$$

$$E_C^I = 6G^I S^2$$

Composite compression modulus

$$E_C = 12 \times E_C^E + 4 \times E_C^I$$

**Results:**

Time Periods of Different Bases

Mode Shape	Time Period Fixed Base(s)	Time Period ERB Base(s)	Time Period LRB(s)
Mode 1	2.206	5	5.073
Mode 2	1.587	4.603	4.685
Mode 3	1.574	2.174	2.219
Mode 4	0.726	1.017	1.032
Mode 5	0.516	0.744	0.768
Mode 6	0.511	0.649	0.657

Mode 7	0.422	0.486	0.488
Mode 8	0.3	0.351	0.353
Mode 9	0.297	0.341	0.344
Mode 10	0.286	0.339	0.340
Mode 11	0.229	0.250	0.251
Mode 12	0.207	0.236	0.237

Following are the results obtained for Base shear, Acceleration and Displacement considering earthquake motion El-Centro (1940) earthquake.

FLOOR	Non Isolator (mm)	ERB (mm)	LRB (mm)
Base	5.3824	17.0383	18.1256
Top	72.8904	126.3369	131.2556

Displacement in X- Direction

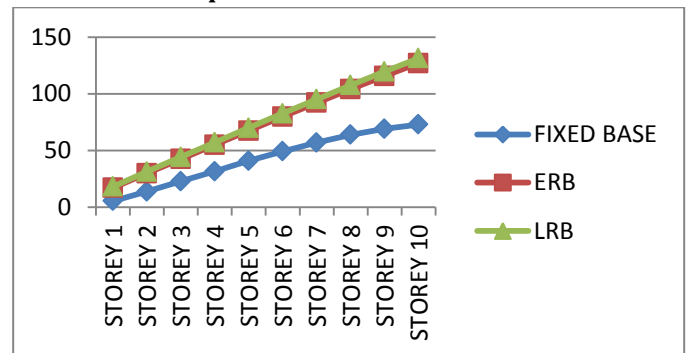

FLOOR	Non Isolator (mm)	ERB (mm)	LRB (mm)
Base	9.6094	23.5952	24.6074
Top	98.1026	145.4486	149.6322

**Displacement in Y- Direction**

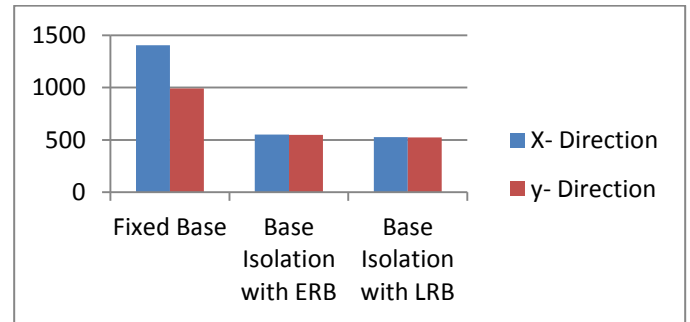
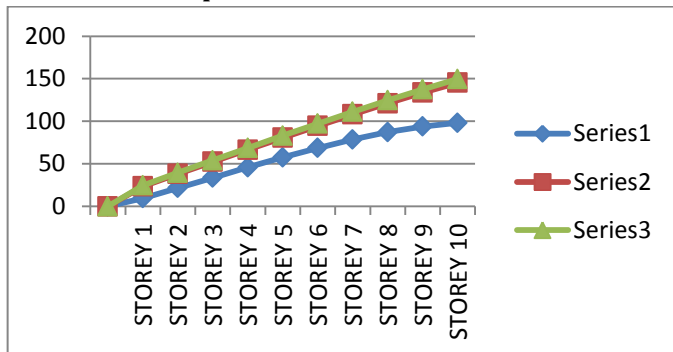

**Base Shear & Storey stiffness:**

Response of Structure	Fixed Base	LRB	FPS
Base Shear (x)kN	1404.939	551.085	526.361
Base Shear (y)kN	991.084	546.730	524.956
Storey Stiffness (Top) KN/m	177592	12427.6	12052.6
Storey Stiffness (Bottom) KN/M	0	0	0

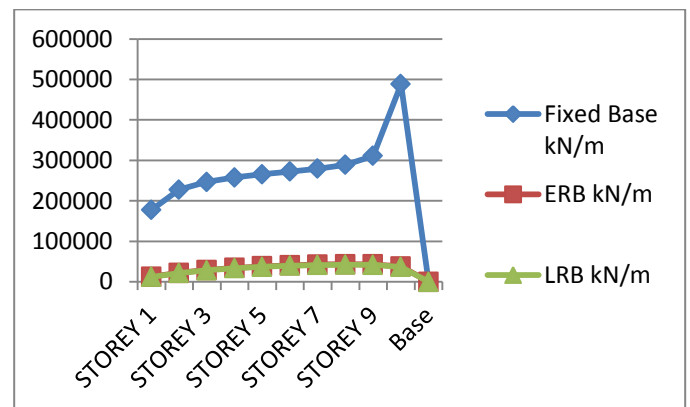

Following are the graphs of base shear and storey stiffness to the time considering the ground motion of El- Centro (1940).

### 7.2 Conclusions

- The time period of structure increases approximately 2 times after providing the base isolator to fixed base structure. Due to this increase in time period, structure experiences fewer amounts of seismic forces. Also it may be concluded that the structure with LRB shows higher time periods than that of ERB.
- The maximum storey displacement in base isolated structure increases. Thus, it can be concluded that use of both ERB and LRB increases the displacement of structure.
- The maximum storey stiffness of structure decreases in base isolated structure. Due to which the Flexibility of structure increases which decreases the probability of collapse.
- The storey drift in base isolated structure increases.
- It can be concluded that for reducing base shear, both ERB and LRB are effective as a Base isolation for structure. However, LRB found to be



performing better than ERB. In case of ERB, maximum reduction in base shear is observed up to 60.78% under El- Centro earthquake, whereas in case of LRB the maximum reduction in base shear up to 62.53% is achieved.

- From the above data, the damage to the base isolated structure will be less as compared to fixed base structure. Thus, structure can be immediately occupied after the actual earthquake.
- If important machinery is installed in structure, due to isolator it is safer and suffers less damage than fixed base building

### References

- CSI Analysis Reference Manual for Etabs@*. [Motion Picture].
- H.P.Santosh, K. M. (2013). Sismic analysis of low rise building for base isolation . *International journal of Research in Engineering and Technology* .
- Raju, N. K. (2012). *Design of Bridges*. New Delhi: Oxford & IBH publishing pvt Ltd. .
- S.J.Patil, G. (1998). Base Isolation for Multistorey building structures . *University of cantebury, Newzweland* , 55-62.
- S.M, D. (2014). Comparative Study for seismic performance of base isolated & fixed base RC structure. *International journal of civil engineering vol.5* , 183-190.