

AN ACTIVE PARTIAL SWITCH POWER FACTOR COORECTION USING HIGH STEP UP INTERLEAVED BOOST CONVERTER

G.KAVINRAJ¹, T.RAJKUMAR²

¹P.G Scholar, Department of EEE, The Kavery Engineering College, Salem

²Assistant Professor, Department of EEE, The Kavery Engineering College, Salem

Abstract - A single-phase, Interleaved AC/DC power factor correction (PFC) rectifier with high gain output voltage is proposed in this paper. For low output voltage product applications, the rectifier is designed to convert high input voltage to low output voltage. Due to no bridge-diodes required and thus decreased input conduction losses, the proposed rectifier efficiency can be improved. The proposed rectifier operates in discontinuous conduction mode and the current-loop circuit is hence not needed. Also, only a single switch is used in the rectifier to simplify the control circuit design. A simple translation method to have the positive output voltage in the interleaved converter is presented in the rectifier to reduce the component counts and the cost as well. The operational principles, steady-state analysis, and design procedure of the proposed rectifier are addressed in detail in this project. Many electronic appliances powered up from the utility, utilize the classical method of ac-dc rectification which involves a diode bridge rectifier followed by a large electrolytic capacitor. The uncontrolled charging and discharging of this capacitor instigates harmonic rich current being drawn from the utility which goes against the international power quality standard limits. Modern ac-dc converters incorporate power factor correction (PFC).

Key Words: Power factor correction (PFC) converter, efficiency improvement, partial switching, inter leaved boost converter.

1. INTRODUCTION

Industrial advancements and the development of information and communication technologies have led to increases in nonlinear loads, which have caused side effects such as increasing the harmonics of distribution systems and malfunction of electronic equipment connected with the grid. To improve power quality, input harmonic regulations such as IEC-61000-3-2 have been implemented. To satisfy such requirements, power factor correction (PFC) converters are adopted as AC-DC pre-regulators of power conversion. In recent years, switched-mode power supply technologies have developed rapidly. Most switched-mode power supplies for electronic products are used to convert AC to DC sources in different applications. The use of a transformer, a bridge rectifier, and capacitors can achieve a DC-output voltage easily, but the input current may be seriously distorted. Therefore, the PFC converters are critically required for AC-DC conversion. A variety of circuit

topologies have been developed for the PFC applications. The conventional PFC converter is a full-bridge rectifier followed by a interleaved boost converter. The converter is widely used, because of its simplicity. However, due to boosting behavior of the converter, the output voltage is always greater than the input voltage. In many applications, such as low-voltage and low-power supplies, it is desired to have the output voltage.

1.1 Block Diagram

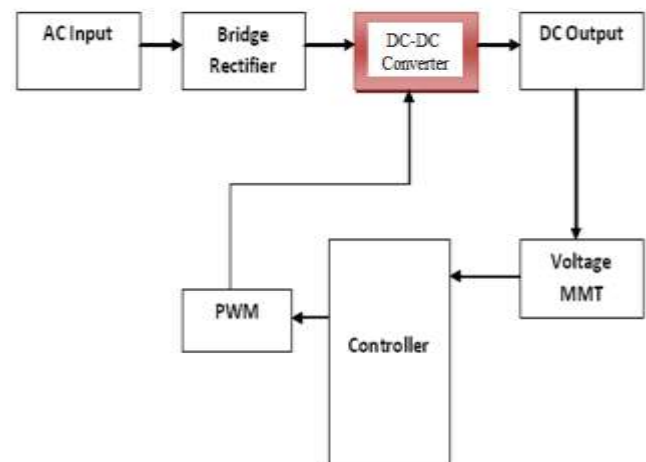

Fig-1: Block diagram of an active partial switch power factor correction using high step up interleaved boost converter

In above the fig-1 Block diagram of an active partial switch power factor correction using high step up interleaved boost converter, It consist of DC-DC converter, PWM, Controller, voltage MMT. The Proposed system connected to an electricity distribution network usually needs rectification. The conventional single phase diode rectifier uses a large electrolytic capacitor to reduce DC voltage ripple, which produces a non sinusoidal line current. So power factor correction (PFC) techniques are gaining increasing attention. The boost topology is most popular than others in PFC applications. This paper presents a two-phase interleaved boost converter which ensures phase shift between the two interleaved converters. The PI controller is used to reshape the input current so as to reduce the harmonics.

1.2 Interleaved Boost Converter:

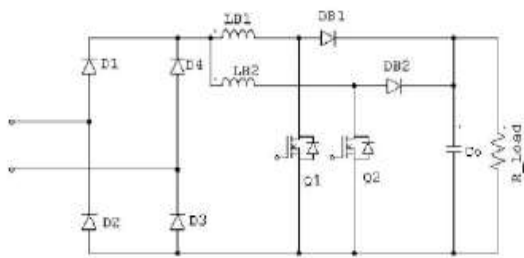

Fig-2: Interleaved boost converter

In above Fig-2 is Interleaved boost converter. The interleaved boost converter, it operates depending upon the interleaving property. The circuit contains two boost converters in parallel operating 180° out of phase. The inductor's ripple currents are out of phase, so they tend to cancel each other and reduce the input ripple current caused by the boost switching action. The input current is the sum of the two inductor currents I_{LB1} and I_{LB2} . Moreover, the effective switching frequency is increased by switching 180° out of phase and introduces smaller input current ripples. **DC TO DC CONVERTERS**

DC to DC converters are important in portable electronic devices such as cellular phones and laptop computers, which are supplied with power from batteries primarily. Such electronic devices often contain several sub-circuits, each with its own voltage level requirement different from that supplied by the battery or an external supply (sometimes higher or lower than the supply voltage). Additionally, the battery voltage declines as its stored power is drained. Switched DC to DC converters offer a method to increase voltage from a partially lowered battery voltage thereby saving space instead of using multiple batteries to accomplish the same thing. Most DC to DC converters also regulate the output voltage. Some exceptions include high-efficiency LED power sources, which are a kind of DC to DC converter that regulates the current through the LEDs, and simple charge pumps which double or triple the input voltage. Linear regulators can only output at lower voltages from the input. They are very inefficient when the voltage drop is large and the current is high as they dissipate heat equal to the product of the output current and the voltage drop; consequently they are not normally used for large-drop high-current applications. The inefficiency wastes power and requires higher-rated and consequently more expensive and larger components. The heat dissipated by high-power supplies is a problem in itself and it must be removed from the circuitry to prevent unacceptable temperature rises.

Linear regulators are practical if the current is low, the power dissipated being small, although it may still be a large fraction of the total power consumed. They are often used as part of a simple regulated power supply for higher

currents: a transformer generates a voltage which, when rectified, is a little higher than that needed to bias the linear regulator. The linear regulator drops the excess voltage, reducing hum-generating ripple current.

1.3 Simulation diagram and results:

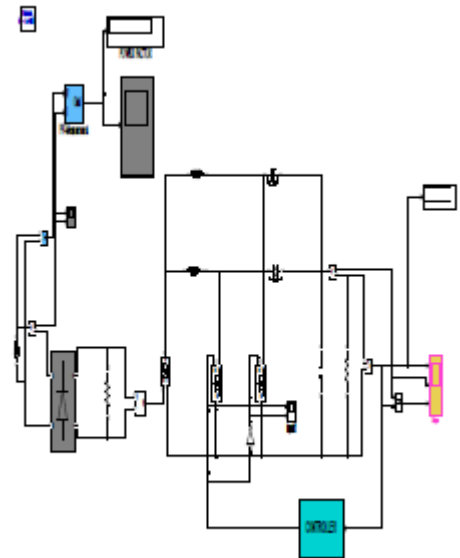

Fig-4: Simulation diagram of active partial switch power factor correction using high step up interleaved boost converter

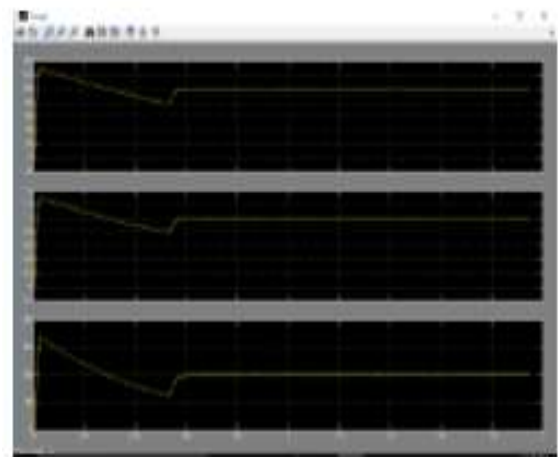

Fig-5: Voltage output waveform

1.4 Partial Switching Boost Pfc Converter

illustrates the partial switching method used in the average current mode control boost PFC. As shown in the figure, switching operation is stopped at an angle at which the output voltage V_o of the boost PFC converter is less than the input voltage V_{in} , and the switching stop point θ_1 and the start point are controlled by adjusting the magnitude of V_o .

However, this method has the disadvantage that it is difficult to precisely control the point at which switching resumes according to the phase delay of the inductor current i_L during the switching stop angle. That is to say, due to the phase delay of i_L , the point at which switching resumes increases from the intended point θ_2 to θ_3 , meaning that the switch-off angle is increased from θ_{off} to θ_{off}' . In addition, because θ_1 and θ_2 vary owing to disturbances such as input voltage variation, load variation, and output capacitor voltage ripple fluctuation, it is difficult to satisfy the input harmonic standard. Furthermore, this method has the limitation that V_o must be less than the peak value of v_{in} .

To overcome the abovementioned problem, this paper proposes a novel active partial switching method in which switching operation is stopped around the peak voltage and zero voltage of the input voltage by using the predictive current mode control PFC illustrated in. As shown by the dashed line in. the adaptive switch-off angle controller detects the switch-off angle around the peak value of the input voltage θ_{off} and generates the output voltage reference $V_{o,ref}$ to maintain a constant switch-off angle. On the other hand, as shown by the dotted line in. the adaptive current shaper, which improves the efficiency by stopping the switching operation at zero voltage, actively controls the adaptive current control variable i_c according to the average output power \bar{P} .

2. CONCLUSION

The Interleaved Boost PFC rectifier with high gain output voltage has been proposed and experimentally verified. The experimental results have shown good agreements with the predicted waveforms analyzed in the paper. The power factor of the circuit has at all the specified input and output conditions. Satisfaction of the requirements can be easily achieved by the proposed circuit. Moreover, with higher efficiency and high power factor the proposed topology is able to be applied to most of the consumer electronic products of 150W rating in the market. Also, with only a single switch employed, the implemented system control circuit is simple to achieve high power factor by applying any PWM control.

REFERENCES

- [1] O. Garcia, J. A. Cobos, R. Prieto, P. Alou, and J. Uceda, "Power factor correction: A survey," in Proc. IEEE PESC, pp. 8–13, May 2001.
- [2] C. Qiao and K. M. Smedley, "A topology survey of single-stage power factor corrector with a boost type input-current-shaper," IEEE Trans. Power Electronics, vol. 16, no. 3, pp. 360–368, May 2001.
- [3] S. Lim, D. M. Otten, and D. J. Perreault, "New AC-DC Power Factor Correction Architecture Suitable for High-Frequency

Operation," IEEE Trans. Power Electronics, vol. 31, no. 4, pp. 2937–2949, Jun 2016.

- [4] C. Zhou, and M. Jovanović, "Design trade-offs in continuous current-mode controlled boost power-factor correction circuits", in Proc. HFPC, pp. 209–220, May 1992.

- [5] Gegner, J.P, and Lee, C.Q., "Linear peak current mode control: a simple active power factor correction control technique for continuous conduction mode" " in Proc. IEEE PESC, pp. 23–27, Jun 1996.

- [6] L. Dixon, "Average current mode control of switching power supplies" in Unitrode Power Supply Design Seminar Handbook, NH, Merrimack:Unitrode Corp., 1990.

- [7] J. Zhang, J. Shao, P. Xu, F. C. Lee, and M. M. Jovanovic, "Evaluation of input current in the critical mode boost PFC converter for distributed power systems," in Proc. IEEE APEC, pp. 130–136, Mar 2001.

- [8] L. Rossetto, G. Spiazzi, and P. Tenti, "Control techniques for power factor correction converters," in Proc. IEEE PEMC, pp. 1310–1318, Sep. 1994.

- [9] Zhang, W, Guang Feng, Yan-Fei Liu, and Bin Wu, "A new predictive control strategy for power factor correction", in proc. IEEE APEC, pp. 403–409, vol.1, Feb. 2003.

- [10] Wanfeng Zhang, Guang Feng, Yan-Fei Liu, and Bin Wu, "A Digital Power Factor Correction (PFC) Control Strategy Optimized for DSP", IEEE Trans. Power electronics, vol. 19, no. 6, pp. 1474–1485, Nov 2004.

- [11] S. Karthick, "Step Up DC-DC Converter with High Voltage Gain Using Switched-Inductor Techniques" International Journal Of Innovative Research In Technology.

- [12] S. Karthick, High Step-Up DC-DC Converter Based on Voltage Multiplier Cell and Voltage-Stacking Techniques for Renewable Energy Applications International Research Journal of Engineering and Technology.