

“Mobile Charging by using Coin Insertion Module and Renewable Resource”

Mrs. Rutuja Deshmukh¹, Nandani Raj², Swati Reddy³, Priya Jadhav⁴

¹Assistant Professor, Department of Electronics And Telecommunication Engineering, D. Y. Patil College of Engineering Akurdi, Pune, Maharashtra, India

^{2,3,4}UG Student, Department of Electronics And Telecommunication Engineering, D. Y. Patil College of Engineering Akurdi, Pune, Maharashtra, India

Abstract- This paper describes the mobile charging by inserting coin in coin sensor module. As the usage of mobile phones is increasing rapidly in day to day life, so to operate these mobile phones mobile charging system at public places play a very important role. Nowadays non-renewable energy is available in less percentage. So use of renewable energy worth billions of dollars. As solar energy is available in abundant amount in nature at free of cost. So this system also uses solar energy to charge mobile phones at public places using solar plate and also have secondary charging source as AC input in rainy season. This system uses solar energy by using solar tracking mechanism which ensures maximum utilization of sunlight for its charging.

Key Words: Renewable, Coin, Coin sensor module, Solar, Solar tracking, LDRs, Mobile phone.

1. INTRODUCTION

As in today's world, mobile phone has become a necessary thing for the people. Today's technically advanced mobile phones are capable of not only receiving and placing the calls but also can store data, taking pictures and many more. Mobile phones help us to stay connected with others and provide the user high security. As the use is increasing an equal amount of power is required to run the application. As in regular routine we can charge the phone easily but as routine changes and if we are on a long journey or in emergency or in some unpredictable situations where we require emergency mobile charging at that time coin insertion mobile charging system plays a vital role where one can easily charge their phone at public places at low cost. This system consists of coin sensing module that recognises valid coins and then signals the microcontroller for further action. If a valid coin is sensed, then the signal is sent to the microcontroller and then microcontroller starts the charging mechanism providing a 5V supply through the power supply.

Now the system also monitor the amount of charging to be provided. So the microcontroller starts the reverse countdown timer to display the charging time for that mobile phone. Now if the user inserts another coin in that time, the microcontroller adds the time to currently

remaining charging time and starts the reverse countdown. The system also uses renewable resource like solar energy to charge the mobile phone by converting solar energy into electrical energy. This system also have secondary source as AC input in rainy season. The system also has solar tracking subsystem which ensures the maximum utilization of solar energy to be done. So this system can be used for smart mobile charging at public places.

2. LITERATURE REVIEW

In 2017, Dhara G. Rangani, Nikunj V. Tahilramani [1] have presented mobile charging using coin in which their main focus was coin detection for which they have used cantilever type sensor for coin detection. Cantilever type sensor detects weight of 5 rupee coin and gives digital signal to ADC. Using this controller check whether coin is original or duplicate. They have also used solar power for charging the mobile station battery and used greed power when solar power is not available.

In May 2017, Mr. C V Raja Reddy, Uzoigwe Daniel, Rupesh Rai, Balaji R [2] have proposed coin based mobile charging with solar tracking in which their main focus was solar tracking for which they have used LDRs so according to the sunlight intensity LDR resistance will be varied. When the sun intensity is high then LDR offers less resistance, the voltage across each LDR is given to the ADC, then controller checks in accordance with the algorithm designed and rotates the motor in specified direction.

In 2015, Nupur Khara [3] have presented a solution to improve the charging and discharging control of battery. The solar charge controller will prevent the overcharging of the battery thus it will help to increase the life of battery. Solar charge controller will also prevent reverse flow of current from the batteries to the solar panels at night.

In 2013, S. B. Sridevi [4] have provided a solution to solar tracking. As sun rises in the east and sets in the west, So if the system cannot change the direction towards sun then it will not be able to consume maximum sunlight this makes the system inefficient so

to overcome the problem solar tracking system has been developed.

3. ARCHITECTURE OF PROPOSED SYSTEM

BLOCK DIAGRAM

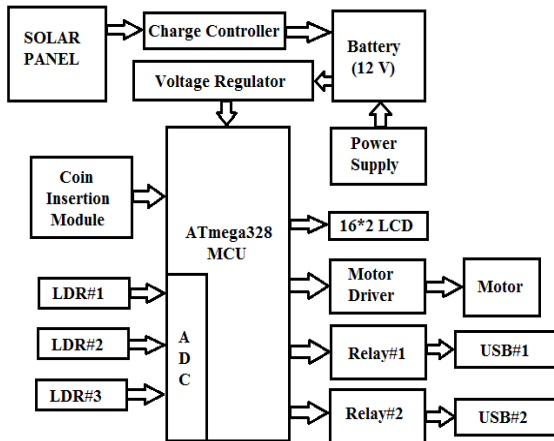

Fig-1: Architecture of proposed system

This proposed system will charge the mobile phone by inserting coin. For coin insertion we are using coin insertion module which will detect the inserted coin, if appropriate coin is detected then it will give the digital signal to the microcontroller otherwise it will refund the coin. Then the microcontroller will ON the respective relay for specific time interval according to the algorithm. This proposed system will not charge the mobile full from 0% to 100% but it will charge according to number of coins inserted. If we add more coins then time will also get added to the charging and reverse count down time will get displayed on LCD. This proposed system will also use the solar energy for charging the battery at mobile charging station and uses AC power supply as secondary source if sun is not available. We use solar tracking system for maximum utilization of solar energy using LDRs. As we are using 12V battery for storing the solar energy so to protect the battery from over voltage we are using charge controller circuit. If battery voltage exceeds 13.5V then charge controller will automatically cut off the supply to the battery and hence battery will get saved from damage due to over voltage.

4. SYSTEM SPECIFICATIONS

4.1. Hardware Specifications

ATmega328:

The Atmel 8 bit AVR RISC -based microcontroller combines 32KB ISP flash memory with read-while-write capabilities, 23 general purpose I/O lines, 32 general purpose working registers, three flexible timer counter

with compare modes , internal and external interrupts, 6-channel 10 bit A/D converter, low power consumption , low cost with feature supported sufficient flash memory for program hex file(up-to 32KB) inbuilt ADC for LDR, sufficient I/O ports and pins, best online support for debugging, open source compiler available (Arduino). The device operates between 1.8-5.5 Volts. It is capable of doing all computations including ADC conversion, solar tracking LDRs.

Coin Insertion module:

Self-programming without PC and automatic self -test for problem, accepts different types of coin at the same time.

1. Coin Diameter: 15mm-32mm
2. Coin thickness: 1.2mm-3.4mm
3. Working voltage: DC+12V±10%
4. Signal output: Pulse
5. Accuracy Rate of identification: 99.6%
6. Working Current: 65mA±%

Solar Panel:

Photovoltaic modules use the light energy to generate electricity through a photovoltaic effect.

No of cells and connections: 36(6x6)

Dimension of module(mm): 650x565x40

Maximum power voltage: 18v

LDRs(Light Dependent Resistors)

Motor Driver

LCD Display

Power Supply And Battery

4.2. Software Specifications

Proteus(PCB Design)

Arduino(Embedded C)

5. EXPERIMENTAL SETUP

The system should be able to charge the battery source of energy i.e. Solar Energy. In rainy season we may charge the battery with AC power source. The solar tracking system attached with the system will be able to use maximum solar energy for charging. The coin sensing module will be able to take Rs. 1,2 and 5 coin and enables the charging for 1,2 and 5 minutes respectively. This system is very much efficient and reliable. The only drawback is that insertion of notes is strictly not allowed.

6. FUTURE SCOPE

As the system uses solar energy so it is very much efficient. It can be installed on railway stations, bus stops

and public places for pay charging facility. The system is very much useful for emergency charging purposes or in rural areas where AC supply is not available for 24x7 hours.

7. CONCLUSION

After analysing the related articles, literatures and a few similar projects the current system was selected. The developed system is able to achieve the primary objectives like charging the mobile phone using coin insertion for a specific duration of time, tracking the maximum sunlight, charge controller to avoid damage to the battery due to over voltage. The system is able to control the communication between various components. In this research we consider a hybrid framework that combines the advantages of power supply charging and solar energy harvesting technologies.

REFERENCES

- [1] Dhara G. Rangani, Nikunj Tahilramani "Coin based mobile battery charger with high security" in IEEE conference, 2017.
- [2] Mr C V Raja Reddy, Uzoigwe Daniel, Rupesh Rai, Balaji R" Coin Based Cell Phone Charger with Solar Tracking system", ISSN:2455-7137, Volume-02, Issue-05,May 2017, PP-46-53, IJLERA.
- [3] Nupur Khara" Design of charge controller for solar PV systems" ICCICCT, 2015.
- [4] Aparna D. Pawar "Coin based solar mobile charger", ISSN:2321-0869,Volume-3,Issue-5,May 2015,IJETR.
- [5] T Chandrasekhar Etal, Mobile Charger based on coin by using solar tracking system, International journal of innovative Research in Science, Engineering And Technology,(An ISO 3297:2007 Certified Organization) Vol. 3, Issue 2, February 2014.
- [6] S. B. Shridevi, A. Sai. Suneel, K. Nalini"Coin based mobile charger using solar tracking system", IJAREC, pp 741-745,Sept.2013.
- [7] K. M. Trautz, P.P. Jenkins, R J. Walters, D. Scheiman, R.Hoheisel, R.Tatavarti, R.Chan, H.Miyamoto, J. G. Adams, V. C. Elarde, and J. Grimsley"Mobile solar Power", IEEE, pp 535-541, Jan.2013.
- [8] S. Banu Prathap, R.Priyanka, G. Guna, Dr. Sujatha" Coin based cell phone charger" International Journal of Engineering Research And Technology(IJERT)ISSN:2278-0181 Volume 2,Issue 3(March 2013).
- [9] www.efyindia.com
- [10] www.nationalsemiconductor.com
- [11] www.alldatasheet.com