

# HYBRID POWER GENERATION BY USING VERTICAL AXIS WIND TURBINE AND SOLAR PANEL

Walunj Pranit<sup>1</sup>, Varpe Vishal<sup>2</sup>, Machhi Amol<sup>3</sup>, Kumawat Mukesh<sup>4</sup>

<sup>1,2,3</sup>B.E Students, Electrical Dept., S.V.I.T, Chincholi, Nashik, Maharashtra, India

<sup>4</sup>Associate Professor, Dept. of Electrical Engineering, S.V.I.T Chincholi Nashik, Maharashtra, India

\*\*\*

**Abstract** - Now a days electricity demand is increasing and to fulfill it the work load on thermal and nuclear plant is going increasing. Because of this the pollution is increasing. So there is need to generate electricity by using renewable energy source. The main objectives behind this project to use the high pressure air created by vehicles on highway to produce electricity by using vertical axis wind turbine. And to increase its efficiency a solar panel also use. That means by using hybrid plant electricity is generated. This electricity is stored in battery for future purpose.

**Key Words:** Vertical axis wind turbine, solar panel, battery, renewable sources, etc.

## 1. INTRODUCTION

Basically our aim is to produce the electricity through the vertical axis wind turbine and solar panel and stored into the battery and use it for street lightning. But for street lightning we need to use multiple sets of this model. Now days the demand of electricity is increasing. According to survey this because of the affordable home appliances. This increases the power demand a lot. So there is need to fulfill this demand. This increases load on non-renewable energy source. This non-renewable sources are going to end. so there is need to produce electricity through non-renewable energy sources.

In our project two types of renewable energy is use to produce the electricity. i.e. wind energy through VAWT and sunlight through solar panel. If the efficiency of a wind turbine is increased, then more power can be generated thus decreasing the need for expensive power generators that cause pollution. This would also reduce the cost of power for the common people. The wind is literally there for the taking and doesn't cost any money. Power can be generated and stored by a wind turbine with little or no pollution. If the efficiency of the common wind turbine is improved and widespread, the common people can cut back on their power costs immensely. Vertical axis wind turbines are economical to run, environment friendly, mechanically strong, light weight, maintenance free. These offer good value for money in the long term.

Also by using solar panel electricity can have produced. This produced energy can be used for various purposes.

## 2. SCOPE

To utilize available wind energy and solar energy resources and reduces the usage of non-renewable energy resources. Wind energy is by far the fastest-growing renewable energy resource. The wind energy industry so far has been supported by market incentives backed by government policies fostering sustainable energy resources. Large-scale wind facilities approaching the output rating of conventional power plants, control of the power quality is required to reduce the adverse effects on their integration into the network. These wind turbines can be used to provide constant lighting. In most cities, bridges are a faster route for everyday commute and in need of constant lighting makes this an efficient way to produce natural energy. Also by use of solar panels the efficiency and the output power generated is increases. For glowing of street light electrical energy is used coming from MSEB. By this project we are using power developed by vertical axis wind turbine's power to glow the street light.

## 3. OBJECTIVES

Primary object of this project is to generate electric power.

1. To reduce the environmental pollution.
2. To save the non-renewable energy for future scope.
3. To reduce the cost of production.
4. To reduce the cost of installation.

## 4. LITERATURE SURVEY

### 4.1 Wind mill

#### 4.1.1 Horizontal axis wind turbine

In this wind turbine the axis of rotation is parallel to wind or ground. The output of this turbine is depends on the diameter of the blade. This system consists of mostly two or three blade. The purpose of the rotor is to convert the linear motion of the wind into rotational energy that can be used to drive a generator.

#### 4.1.2 Vertical axis wind turbine

In this wind turbine the axis of rotation is perpendicular to wind or ground. Key advantages of this arrangement are that the turbine does not need to be pointed into the wind to be

effective. The key disadvantages include the low rotational speed with the consequential higher torque and hence higher cost of the drive train, the inherently lower power coefficient. The output of this turbine depends on height of the axis.

## 4.2 Solar power system

### 4.2.1 Off grid solar power system

It is battery based solar system. Solar panel supply power to load and balance energy is stored in battery bank and with the help of inverter the quality of power supply to consumer.

### 4.2.2 On grid solar power system

In this type of solar panel power system the PV generate power only when the utility power grid is available. They must be connected to grid to function. The grid connect inverter converts DC electricity produced by solar panel into 240V AC electricity.

## 5. BLOCK DIAGRAM

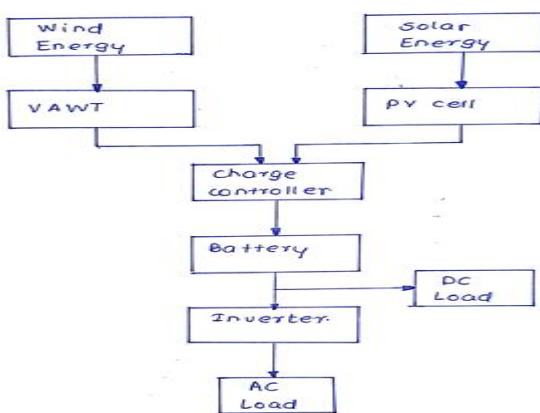

## 6. WORKING

1. The moving vehicle on highway produces pressurized air. the vertical axis wind turbine converts this air into mechanical motion. Then this mechanical motion gets transferred to the generator by mean of shaft. This generator converts this mechanical motion into electrical power. then this power is stored in battery.

2. Solar panel works on following principle, sunlight knocks electrons free from atom, then the flow of electrons generating a flow of electricity. In PV sunlight is get converted into electricity.

3. Then after the electricity from both the sources is get collected and stored in battery for future purpose.

## 7. CONCLUSION

This system is environmental friendly. The working model of our project is combined energy source with solar system and vertical axis wind turbine system which is a good and effective solution for power generation, basically this system involves the combination of two energy system, suppose anyone source fails to generate another source will keep generating the electricity and will give the continuous power to the load. The renewable energy sources such as solar and wind energy are used to generate the electricity.

## REFERENCES

- [1] r.sathyannarayanan, s.muthamizh, highway windmill, 2011, 978-1-61284-2, sri ram engineering college chennai, india, 978-1-61284-486-2/111\$26.00 ©2011 ieee
- [2] wei qiao, anuj sharma, jerry l hudgins, wind/solar hybrid generation – based roadway micro-grids, 2011, 978-1-4577-1002-5/11
- [3] shweta singh, sarita singh and priyanka srivastava, vertical axis wind turbine for generation of electricity through highway windmill, 2015, vol no: 07, issue no: 02.
- [4] bhadane pratik.s, rathod sneha.a, vertical axis highway wind mill using magnetic levitation, 2017, vol no: 02, issue no: 05
- [5] [https://wahiduddin.net/calc/density\\_altitude.html](https://wahiduddin.net/calc/density_altitude.html) - for calculating the velocity and the density of the wind turbulence.
- [6] <https://www.brisbanehotairballooning.com.au/calculators/air-density/> - for calculating the air density
- [7] <https://www.windpowerengineering.com/design/vertical-axis-wind-turbines/> - survey for the calculations which is required for the VAWT

## AUTHORS



Mr. Walunj Pranit  
B.E Student Electrical Dept., S.V.I.T.  
Chincholi, Nashik, Maharashtra,  
India



Mr. Varpe Vishal  
B.E Student Electrical Dept., S.V.I.T.  
Chincholi, Nashik, Maharashtra,  
India



Mr. Machhi Amol  
B.E Student Electrical Dept., S.V.I.T.  
Chincholi, Nashik, Maharashtra,  
India



Prof. Kumawat Mukesh  
Associate professor, Electrical  
Dept., S.V.I.T., Nashik,  
Maharashtra, India