

Graphene based Terahertz Patch Antenna

Babitha M¹, Takshala Devapriya A²

¹PG Student, Department of Electronics and Communication Engineering, MZCET, Karaikudi, Tamilnadu, India

²Assistant Professor, Department of Electronics and Communication Engineering, MZCET, Karaikudi, Tamilnadu, India

Abstract - Terahertz wave has been generally utilized in correspondence fields for rapid transmission and it infiltrate textures and plastics. The Microstrip based patch working in THz ranges for remote applications. The performance is investigated for polyimide, rubber, polyethylene and polyamide materials, its result are not efficient. So Graphene material is utilized, it has a superior execution in the parameters of return loss, voltage standing wave proportion (VSWR), Gain and radiation effectiveness. A Microstrip patch antenna using graphene has been designed and simulated at 2.8THz a return loss of -18.7 dB and VSWR 1.28 has been calculated. The graphene based adaptable reception apparatus utilized for a future THz application.

Key Words: Graphene, Micro strip antenna, flexible, THz communication

1. INTRODUCTION

The steady development in clients requests for the information rates in remote systems lead to the ceaseless increment in the measure of recurrence space assets, allotted per client [1][2]. Because of the way that vast densification of remote systems with passageways has clear impediments; this interest is normally changed over to the further increment in the all out transmission capacity involved for radio access innovations[3][4]. The intrinsically little correspondence scope of THz cells motivated the network to look for the situations, where little (few meters sweep greatest) and amazingly high-rate cells can be utilized in the most proficient way [6]-[8]. Fig. 1 shows the terahertz wireless communication.

The relevance of THz correspondences to commonplace use situations (for example indoor WLAN get to) is restricted because of extensive engendering misfortunes [9].

This could be tended to by exchanging the limit of THz passages for inclusion, essentially by decreasing the used data transmission and moving the whole interchanges from over 1 THz to the supposed "bring down terahertz" transporters around 300GHz[10]. Accordingly, it is conceivable to make dependable remote connections more than several meters while holding the limit of many gigabits every second, which makes Wi-Fi-like THz passageways wind up plausible. This usage is both a standout amongst the most attractive ones, yet in addition testing because of prerequisite of crystal shaft following and viable medium access control. A capacity to make very directional bars with smaller than expected size reception apparatus clusters related to the high hypothetical limit of THz joins results in various advantages for the security-delicate utilization, particularly in military applications. The normal military situation gives a combat zone various heterogeneous units (troopers, protected work force transporters, tanks, and so on.) framing a THz specially appointed system.

2. GRAPHENE

Carbon most likely comes in two essential yet startlingly extraordinary structures (or allotropes), in particular graphite (the delicate, dark stuff in pencil "leads") and precious stone (the super-hard, sparkly gems in gems). Interestingly, both these profoundly extraordinary materials are made of comparative Carbon molecules. The structure of graphene appeared in Fig. 2. The subatomic inside the two materials are organized in various ways, and this is the thing that gives the two allotropes their totally unique properties: graphite is dark, dull, and generally (delicate and hard pencils blend graphite with different materials to make darker or fainter lines); precious stone is limpid and the arduous regular material so far found.

A lots of atoms arranged in a stock, boundless repeating, three-space time structure a bit like an atomic climbing chassis, only instead of bars there are obscure bonds between the atoms that clamp unitedly. Diamond and graphite eleven have a three-space time arch, though it's carry out different: in diamond, the atoms are tightly bonded in three-dimensional tetrahedrons, whereas in graphite, atoms are bonded tightly in two-dimensional layers, which

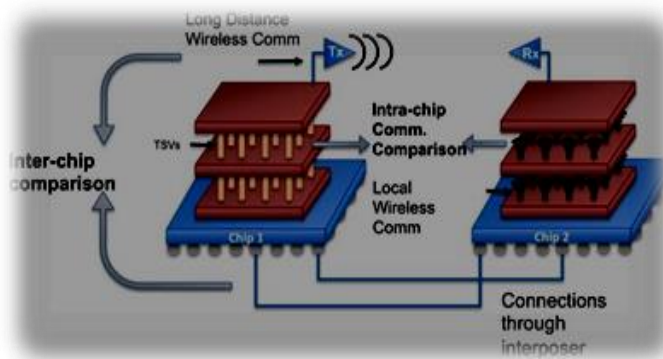

Fig-1: THz communication via graphene

are clasp to the layers above and below, by relatively anemic forces.

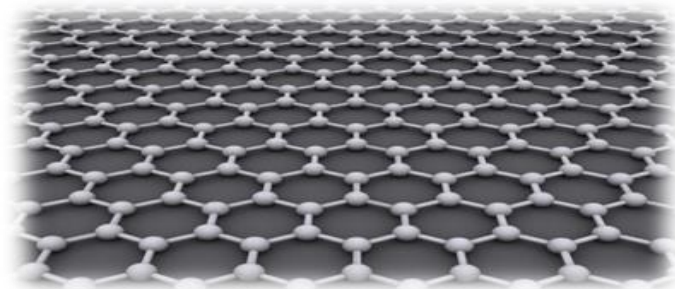

Fig-2: Graphene structure

Graphene is an aqueous with a dense of 0.34 nanometer. It is shaped from carbon molecules in sp² hybridization state, masterminded with the end goal that every carbon iota is covalently attached to three others. Thus, graphene is a nano jacquard with a honeycomb cross section framed from two interpenetrating triangular sub grids. It is the world's most snout material and one of the hardest and most grounded materials. In fact, the previous couple of years have seen a blowup of scrutiny into the properties and potential uses of graphene, which has been touted as a better option than silicon. At present there are essentially four strategies to deliver graphene.

The first is mechanical shedding with sticky tape from exceedingly requested pyrolytic graphite which has a low yield however the high caliber. The second is the epitaxial development of graphene on a silicon carbide substrate, which must be ardent at temperatures more noteworthy than 10000 C. The third technique depends on graphene oxide (GO), which is scattered in hydrazine and stored on different substrate uniform film that contains single or few layer graphene.

3. MICROSTRIP ANTENNA

Miniaturized scale strip reception apparatuses are likewise alluded to as fix radio wires. They are low profile, comparable to planar and non-planar surfaces, straightforward and economical to make utilizing presentday printed-circuit innovation, mechanically strong when mounted on unbending surfaces, good with MMIC structures and when the specific fix shape and mode are chosen.

4. Simulation Tool

HFSS – High Frequency Simulation Software. It is an industry-standard reenactment instrument for 3D full-wave electromagnetic field reproduction. It is fundamental for the structure of high recurrence and rapid part plan. HFSS is high recurrence structure test system it is elite full wave electromagnetic field test system 3D volumetric detached gadget demonstrating that takes favorable circumstances of

recognizable Microsoft Windows graphical UI. It incorporates reenactment, representation, strong displaying and machine in simple to learn condition

5. Design

The design of Microstrip patch antenna using a graphene material shown in Fig. 3. In the design silicon substrate and graphene patch is used. Its resonating frequency range is 2.8 THz. It has a -18.7 db return loss and VSWR value is 1.28; it can be shown in the Fig. 4(a) and (b).

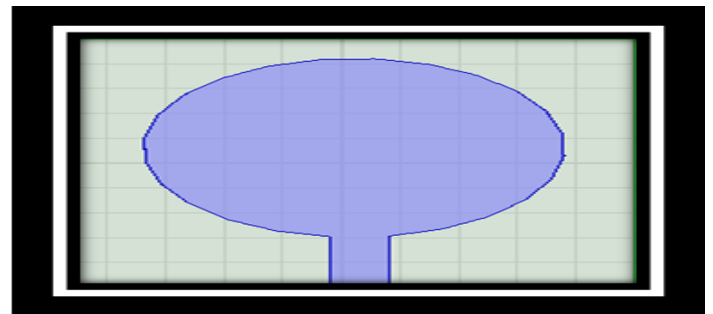
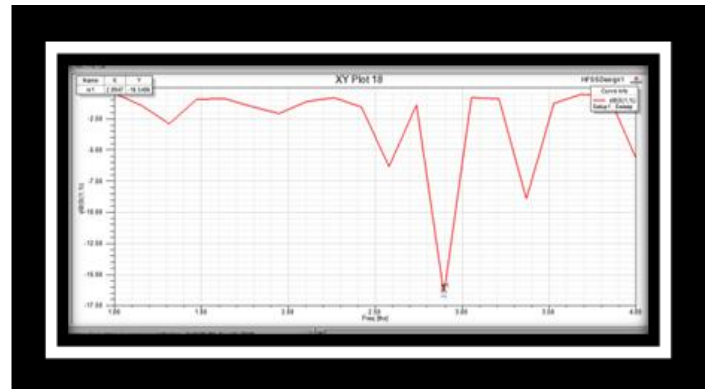
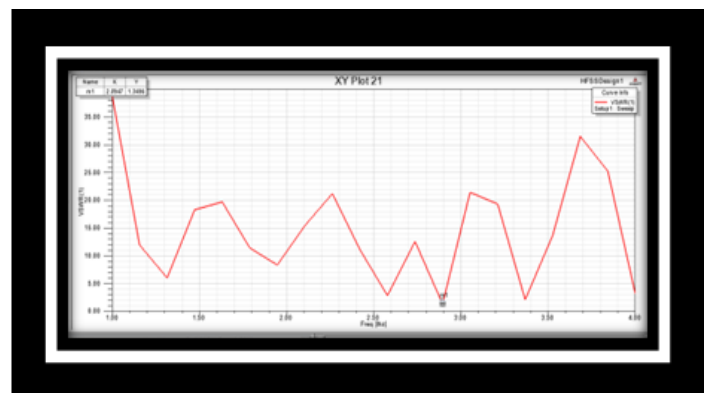

Fig-3: Microstrip patch antenna using graphene



(a)



(b)

Fig- 4: (a) Response for return loss, (b) Response for VSWR

6. COMPARISON RESULTS

In the Microstrip patch antenna design Fig.3 change the material for patch and analyzed the results. But it does not provide a better performance.

Table -1: Comparison results

PATCH MATERIAL	FREQ (THz)	RETURN LOSS	VSWR
Polyimide	2.9	-3.515	5
Polyamide	2.2	-2.944	8.8
Polyethylene	3.3	-2.94	5
Rubber	2.5	-1.46	11.8

B. Polyimide

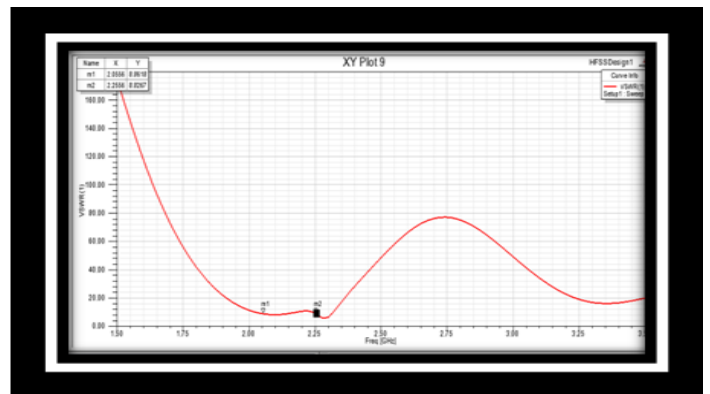

(a)

A. Polyamide

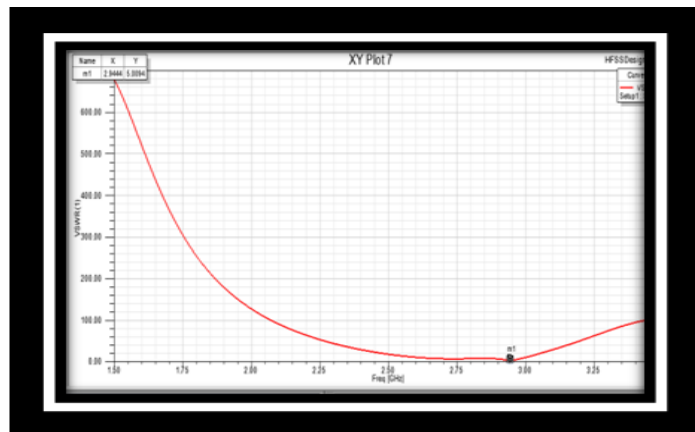

(a)

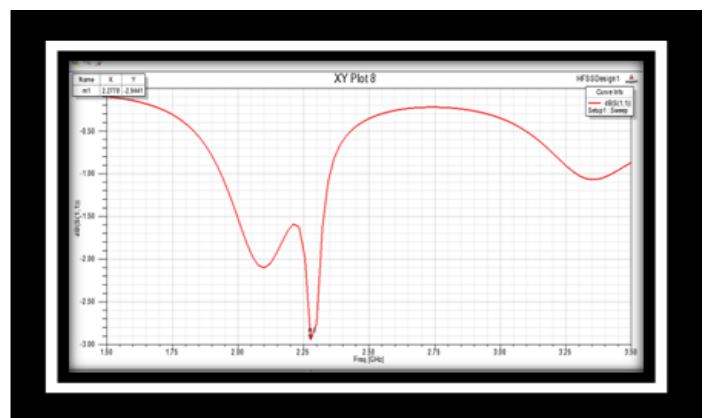

(b)

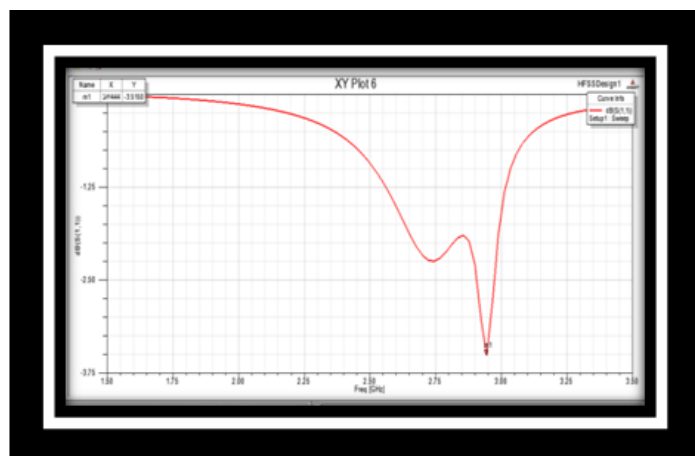

(b)

Fig-5: (a) Response for VSWR, (b) Response for return loss

Fig- 6: (a) Response for return loss (b) Response for VSWR

C. Polyethylene

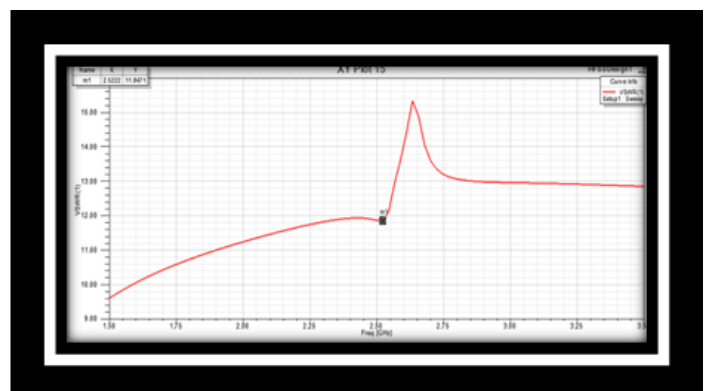

(a)

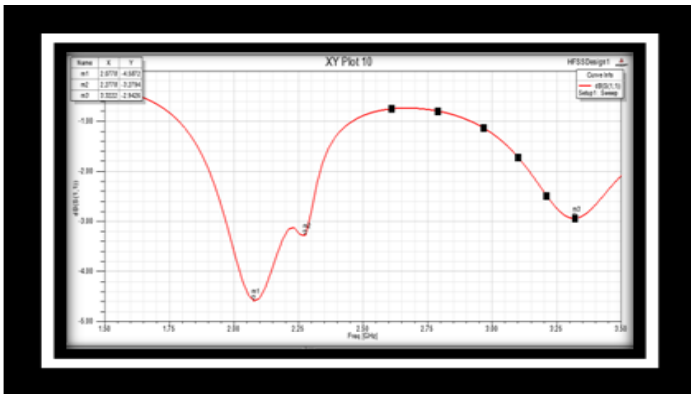

(b)

Fig-7: (a) Response for return loss, (b) Response for VSWR

D. Rubber

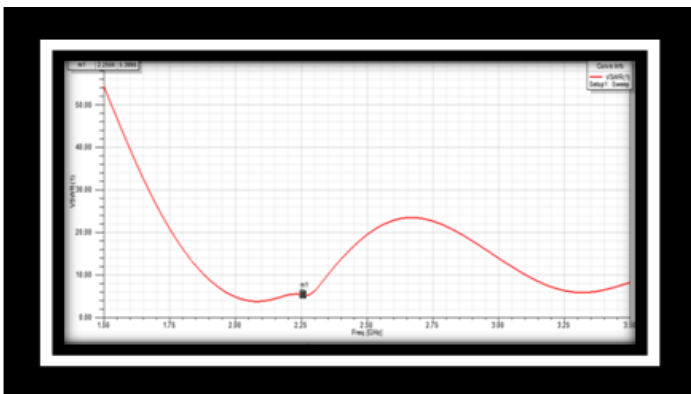

(a)

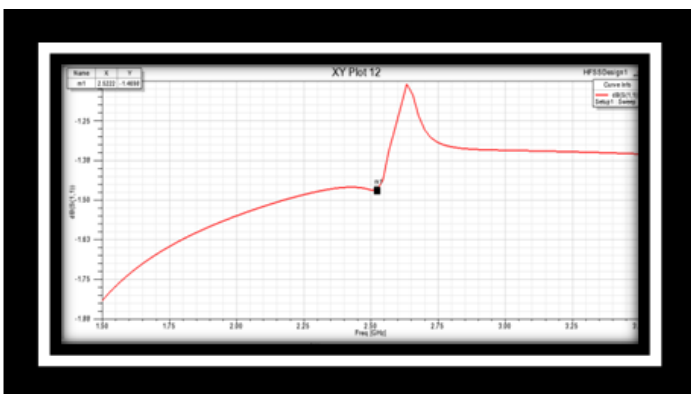

(b)

Fig-8: (a) Response for return loss (b) Response for VSWR

7. CONCLUSION

The realized antenna could achieve an 80% over a operating range is a reported data for a adaptable substrate, low dielectric constant for a material help to improve the antenna performances. Whereas optimized design facilitates simple and miniature antenna with large bandwidth. This promotes easy fabrication and compatible. The outcomes indicate improvement in antenna parameters.

REFERENCES

- [1] Wu, Yongle, et al. "Graphene-based Yagi- Uda antenna with reconfigurable radiation patterns." AIP Advances 6.6 (2013): 065308.
- [2] Azizi, Mohamed Karim, et al. "Terahertz Graphene-Based Reconfigurable Patch Antenna." Progress In Electromagnetics Research 71 (2015): 69-76.
- [3] Bozzi, Maurizio, Luca Pierantoni, and Stefano Bellucci. "Applications of graphene at microwave frequencies." Radioengineering 24.3 (2015): 661-669.
- [4] Sankaralingam, S., & Gupta, B. (2016). Development of textile antennas for body wearable applications and investigations on their performance under bent conditions. Progress In Electromagnetics Research, 22, 53-71.
- [5] Correas-Serrano, Diego, and J. Sebastian Gomez-Diaz. "Graphene-based antennas for terahertz systems: A review." arXiv preprint arXiv:1704.00371 (2016).
- [6] Murugan, Siva Agora Sakthivel, and K. Karthikayan. "A compact T-fed slotted microstrip antenna for wide band application." International Journal of Scientific & Technology Research 2.8 (2017): 291-294.
- [7] Adlin, A., and K. Madhan Kumar. "Design and analysis of flame retardant material based microstrip patch antenna for the detection of semtex."
- [8] Sedghi, Mohammad Sadegh, Mohammad Naser-Moghadasi, and Ferdows B. Zarrabi. "Microstrip antenna miniaturization with fractal EBG and SRR loads for linear and circular polarizations." International Journal of Microwave and Wireless Technologies 9.4 (2017): 891-901.
- [9] Goyal, Rahul, and Dinesh Kumar Vishwakarma. "Design of a graphene-based patch antenna on glass substrate for high-speed terahertz communications." Microwave and Optical Technology Letters 60.7 (2017): 1594-1600.
- [10] Jornet, Josep Miquel, and Ian F. Akyildiz. "Graphene-based plasmonic nano-antenna for terahertz band communication in nanonetworks." IEEE Journal on selected areas in communications 31.12 (2018): 685-694.