

FIRE FIGHTING ROBOTIC VEHICLE

Prof. A.H. Sale¹, Sanket R. Gaykar², Akshay U. Jadhav³, Sankalp S. Nikam⁴,
Manohar D. Sonawane⁵

¹Professor, Electronics and Telecommunication, Bharati Vidyapeeth College of Engineering, Navi Mumbai, Maharashtra, India

^{2,3,4,5}Student, Electronics and Telecommunication, Bharati Vidyapeeth College of Engineering, Navi Mumbai, Maharashtra, India

Abstract - This project deals with detection and prevention of fire. Fire can cause problem and damage due to the absence of a human. In fire affecting the area, there are many times where a human can't reach easily or there is a risk to loss of life. If fire extinguished by a robot we can avoid loss of life. Using robot we can detect and extinguished a fire in early stages. Robotics has the power to do almost anything and gained popularity. In our day-to-day life fire accidents have become common and may lead to hazards making the life of firemen difficult so in such cases we can make use of robots. Properly equipped Robot will detect fire. Once the fire is detected equipped robot can be instructed to extinguish a fire. The robot is mounted with sensors and fire extinguisher. The light and a smoke sensor will detect fire and extinguisher will extinguish a fire. In this paper, we will discuss the development of an android application that will control the robot. In this way, we develop a full equipped robot to perform fire fighting.

Key Words: Fire extinguishing, Android application, Bluetooth, Robot, sensors, microcontroller

1. INTRODUCTION

The robot is an electromechanical design that is capable of performing a human task and also reducing workload. In our day-to-day life fire accidents have become common and may lead to hazards making the life of firemen difficult so in such cases we can make use of robots. Our project makes use of Bluetooth tech. for remote operation and also uses a microcontroller the main goal of our project is to make human life a little easier by making use of robots in a difficult situation where human life is in danger. In many cases, fire occurs in mills, garment factories which is difficult for a human to handle so using a robot is the best way to tackle such a situation. Also, the robot is designed in such a way that it detects the fire and also takes necessary action before the situation is going out of control. We are optimistic that the role of robotics will be used in a much better way in the future to solve many such problems

1.1 Major Components

1) AT mega 16

AT mega 16 is high performance 8-bit microcontroller. It is a 40 pin microcontroller based on RISC architecture with 131 instructions. It has 16KB programmable flash memory static

RAM of 1KB and EPROM of 512 Bytes. There are 32 I/O lines which are divided into four 8-bit ports.

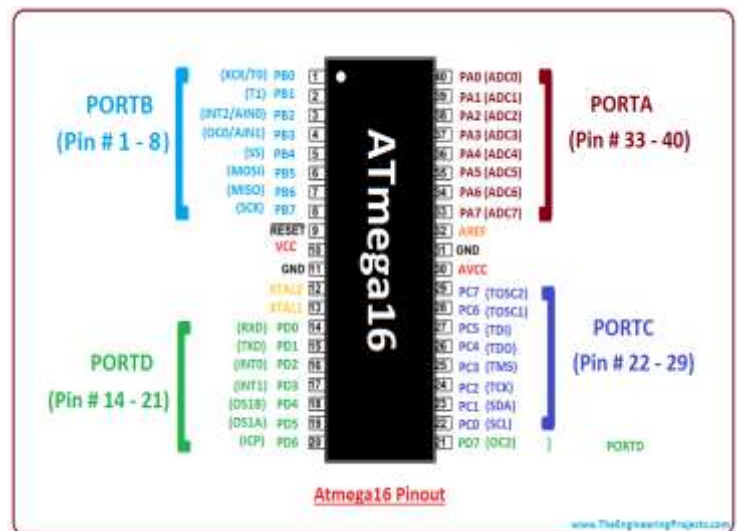

2) BLUETOOTH MODULE HC-05

HC-05 Bluetooth module is a module which can add two way (full duplex) wireless functionality. We can use this module to communicate between the two microcontrollers. The module communicates with the help of USART at 9600 baud rate which makes it easy to interface.



3) LM 7805 Series voltage regulator

7805 is a voltage regulator. It is a member of the 78xx series of fixed linear voltage regulator IC. The xx indicates the fixed value it provides as 7805 provides a constant voltage of 5V.

4)CRYSTAL Oscillator

A crystal oscillator is an electronic component which uses mechanical resonance of vibrating crystal to generate a clock or frequency.

5)LCD

A 16X2 LCD display is a basic module but this is widely used in many devices and circuits. A 16x2 LCD has the ability to display sixteen characters for one line and another sixteen character for the second line. LCD has two register namely command and data. The command register stores various command instruction given to the LCD while the data register stores the data to be displayed.

6) Thermistor

The thermistor is temperature sensing elements made of semiconductor material. NTC thermistor is non-linear resistors which change its resistance with an increase in temperature. The resistance of NTC will decrease with a change in temperature. The manner the values changes it depends on constant Beta.

7) Gas sensor

The MQ-6 gas sensor can detect and measure gases like LPG and butane. The sensor comes with a digital pin which makes it operate without a microcontroller and this particular helps to detect any particular gas.

8) Relay

The relay acts as a switch and open and close circuits electrically. It controls circuit by stop flop of current between two points (i.e. open) and starts a flow of current (i.e. close). In our project, we used a relay for controlling motors and pump. Its acts as a motor driver

1.2 LITERATURE SURVEY

Mr. kristikosasih et al. Has developed the intelligent fireplace preventing tank robotic. Acrylic, plastic, aluminum, and iron are used to make the robotic. The tank robotic is together with additives like servo cars, a thermal array sensor, dc cars, flame detector, ultrasonic sensor, ir and image transistors, sound activation circuit and microswitch sensor. The purpose of a paper is to search the prescribed place to locate the fire and extinguish it. The robot is activated through the use of DTMF transmitter and receiver.

Mr. sahils.Shah et al. Have developed the fire preventing robotic. The fire fighting robot is integrated with an embedded system. A prototype system is designed to hit upon and extinguish a fire. It objectives to lessen air pollutants caused due to a hearth. The golem is supposed to discover a fire in the tiny architectural plan. The challenge of extinguishing hearth is divided into smaller obligations. Every challenge is finished in the most suitable way. The robotic navigate in each room step by step, unearths the hearth in a room, techniques fire from constant distance after which extinguishes fireplace

2. Block Diagram

2.1 Transmitting Side

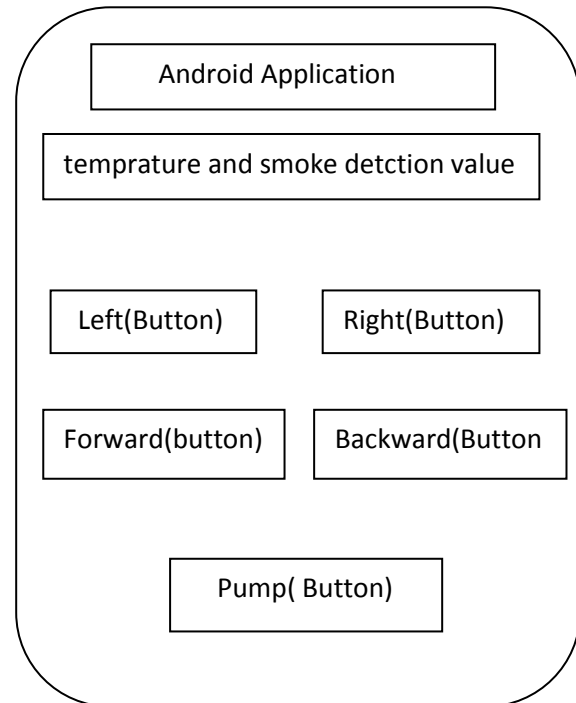

2.2 Receiving side

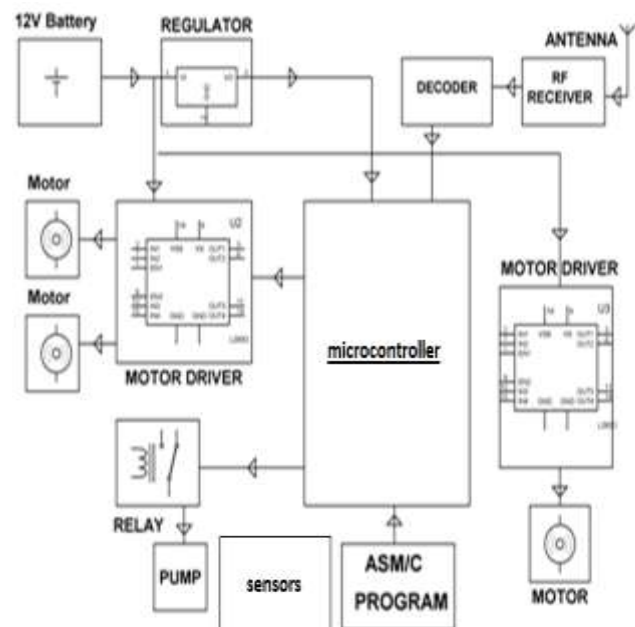

3. Working

To pressure every one of the components inside the recipient area 5v dc and 12v dc are required. 6v batteries

associated in an arrangement are utilized to offer the obliged power to the circuit. Because the microcontroller and extraordinary segments inside the circuit requires directed 5v supply a voltage on the recipient vicinity the records are gotten with the aid of the rf collector. For the reason, that information is encoded amid the transmission it has to be decoded earlier than reinforced to the microcontroller. Ht 12d receive and disentangle 12 bit encoded statistics transmitted by ht12e, for further making ready. The ht12d is 12-bit decoders are a progression of CMOS LSI for remote manage framework packages. They're mixed with Holtek's 2¹² association of encoders. For legitimate operation, more than one encoder/decoder with the identical quantity of locations and facts configuration should be picked. The decoders get serial places and records from a customized 2¹² arrangement of encoders that are transmitted by way of a bearer utilizing arf transmission medium. They study the serial statistics three instances constantly with their residential locations. At the off hazard that no mistake or unrivalled codes are observed, the records codes are decoded and later on exchanged to the yield pins. The vt stick likewise is going high to demonstrate a big transmission. The 2¹² association of decoders are ready for decoding records that incorporate of n bits of a region and 12_n bits of statistics. Of this association, the ht12d is organized

To give 8 deal with bits and 4 records bits. This fact is then given to the microcontroller. The microcontroller paperwork these statistics as indicated by way of the information were given that is which order is acquired. To give the orders to the robotic switches are applied here are 4 switches are related for ahead, in reverse, right and left improvement of the robotic. The robot is stacked with a water tanker and a pump which is controlled over far off correspondence to toss water. At the accepting end, 5 engines are interfaced to the microcontroller where 4 of them are utilized for the movement of the car and the only is to place the arm of the robot. What's greater, one dc pump engine is utilized for the hobby of the water pump. The receiver interprets earlier than nourishing it to another microcontroller to drive dc engines via engine motive force for critical work. A water tank alongside water pump is installed on the robot frame and its operation is done from the microcontroller yield through a suitable signal from the transmitting end. The entire operation is controlled through % microcontroller. A transfer motive force ic uln2803a is interfaced to the microcontroller thru which the controller drives the engines. On this application engine, 1 and engine 3 are pressure to transport the robot within the ahead heading. The engine 2 and four are pressure to transport the robot in the regressive heading. To transport the robotic inside the left course engine 1 and 4 have to be empowered. What is more, for the proper improvement of the robotic engine 2 and 3 are utilized. Engine five will circulate the arm of the robotic up and down. At the factor while there

Is a charge "flame" is received then to empower water pump the engine 6 might be empowered and the water is tossed

out via the water pump. The hobby of the water pump relies on at the yield of the flame sensor. Here the flame sensor is a thermistor. The flame sensor is interfaced with the microcontroller and mounted at the robotic frame. To stop the activity of the framework the recipient should get the paired code of 1111. In addition, the challenge may be progressed with the aid of interfacing it with a far off digicam in order that the character controlling it may see the operation of the robotic remotely on a screen. A VGA far-flung camera is applied as part of this anticipates. A VGA camera utilizes a visible illustrations cluster of 640 pixels wide and 480 pixels high, approximately what would possibly as properly be referred to as a 0.3-megapixel photograph. Regulator ic 7805 is applied. A few air conditioner swells may be available in the delivery. These blunder heartbeats are removing through utilizing capacitor channel.

AT mega 16 is a 40 pin IC. To start a controller we require 3 main things

- 1) Powe supply
- 2) Clock
- 3) Reset

It is a 40 pin IC from which pin 11 and 31 are power supply pins .11 is analog supply and 31 is digital supply. Both have given a supply of 5V. Pin 10 and 30 are ground pins. Pin 12 and 13 are crystal oscillator pins. In the crystal oscillator, we have 2 capacitors of 22pf and value of crystal is 11.0592 MHZ. Pin 9 is a reset pin in which we have a resistor of 1k, capacitor of 1micro farad and power supply of 5V. This is called 'Power ON Reset'.

As soon as the power supply is ON A pulse will be given to the controller and the controller will reset and program from 00000H memory location will be started. The controller has 4 Ports

- 1) PORT A
- 2) PORT B
- 3) PORT C
- 4) PORT D

PORT A has built-in ADC while PORT D first 2 pins are Transmitter and Receiver used for serial communication. This robot will be going to communicate with our android application with the help of Bluetooth. And Bluetooth module used is HC-05. It has a built-in antenna and operating frequency is 2.4 GHz and the standard baud rate is 9600 for serial communication. It is a class 1 module and in open area, it has a range of 10 meters. We have class 2, class 3 modules also which has a range of 50 meters and 100 meters. Any trigger that we send from mobile is received here with the help of Bluetooth. The received message should be displayed for that we require a display so PORT C has an LCD display. This display is of 16x2 in which we have a ground pin which

is connected to ground. We have a contrast pin to adjust the brightness of LCD. It has 3 control pins

- 1) Rs -Data command
- 2) R/w-Read / Write
- 3) Enable

From these pins, Data command pin and enable pin is given to the controller. R/w pin is connected to the ground. It has 8 data pins from (D0 to D7). But port C doesn't have that many pins so we connect only 4 pins from (D4 to D7).

Sensors used are Temperature and gas sensor. The thermistor is used as a temperature sensor which is 10k NTC and gas sensors used is MQ-6. The relay is an electro-mechanical switch and is used to provide supply to motor and relay is of 12 V.

4. CONCLUSIONS

This system can be used in a difficult situation where destruction is more and to avoid any problems in human life. We can even remove obstacles which can make easier for firemen. These days the robot era has a prime position inside the advancement of an era. Maximum of the workers are shifting closer to the carrier region and no longer to the economic region. As an end result, there exists a scope for automating all of the operations executed by way of the workers in industries.

The paradigm evolved is a lot of consumer-friendly and fewer dearer. It'll perform the preferred operation very smoothly. The device can be managed inside more than a few 10 meters the use of any android smart smartphone, that allows you to be extra applicable in packages which include bomb defusing, far-flung choose and location, cleaning applications.

In addition to improvement, the robotic arm may be designed for different programs like in gardening, agricultural programs, and many others. Exclusive sensors are accustomed have a look at the location of the items and also the complete approach is automatic and it may speak with person thru networking.

REFERENCES

- 1)B.Swetha Sampath (2011) Automatic fire extinguisher robot 8th international conference on ubiquitous robots and ambient intelligent nov 23-26 songdo conventia, Incheon, Korea
- 2) PoonamSonsale, RutikaGawas, Siddhi Pise, AnujKaldate , "Intelligent Fire Extinguisher System"
- 3)Kristi Kosasis, E.Merry Sartika, M. Jimmy Hasugian, Dan Muliady (2010) The Intelligent Fire Fighting Tank Robot Electrical Engineering Journal Vol.No. 1, pp. 73-80 (PDF)

- 4)Prof.AmolJoglekar, "Cell Phone Controlled Robot with Fire Detection Sensors", International Journal of Computer Science and Information Technologies, Vol. 6 (3), 2954-2958
- 5)Arduino Yun datasheet, <http://docs-asia.electrocompetent.com/webdocs/1409/0900766b81409bb2.pdf> DHT 11

- 6) Saravanan P, "Design and Development of Integrated Semi-Autonomous Fire Fighting Mobile Robot", International Journal of Computer Science and Information Technologies Volume 4, Issue 2, March 2015

- 7) sensor datasheet, <http://files.amperka.ru/datasheets/dht11.pdf> (PDF)

- 8)Arpit Sharma, ReeteshVerma, Saurabh Gupta and SukhdeepKaur Bhatia, "Android Phone Controlled Robot Using Bluetooth", International Journal of Electronic and Electrical