

Design Development Analysis and Testing of Re-Usable Sacrificial Vehicle Crash Energy Absorber - Impact Damper

Nikhil Pisal¹, Prem Sawant², Abhishek Garud³, Ansar Shikalgar⁴, Akshay Kadam⁵

¹Professor, Jaywant College of Engineering and Management, K.M.Gad, Shivaji University

^{2,3,4,5}Student, Jaywant College of Engineering and Management, K.M.Gad, Shivaji University

Abstract - The problem of accident of speeding vehicles in highway transportation is common but very crucial. Traffic accident leads to loss of life and property. We cannot avoid accidents completely but impact of accident we can reduce by applying safety measures, safety instrument. Safety impact guard is one of the safety instruments which can reduce collision impact at rear end collision when accident occurs. Also provide safety against under ride crashes which is cause due to passenger vehicle collides with the truck or trailer. Proposed design of safety impact guard includes a damper with pressure relief valve as force destroying material. Because of that when rear end collision is occurs the force or energy or impact is destroyed due to action of the damper with pressure relief valve. Another aim of this project is to reduce the height of safety impact guard from ground so that the truck under ride crashes should be avoided. So that we can save the life and prevent the loss of property. The objective of this entire project would be of possible design of rear impact guard which provides safety against rear end collision.

Key Words: Impact, PRV- Pressure relief valve, Damper,

INTRODUCTION

The potential for energy absorption within the front structure of a passenger vehicle may be optimized for specific loading e.g. high-speed rigid flat barrier impact. In many vehicles energy absorption is provided by the axial collapse of longitudinal frame members. These structural members work well when loaded as intended but may not always perform so effectively in vehicle crashes on the road. In the study described here the controlled bending rather than axial collapse of the main longitudinal members has been used to reliably manage the energy from frontal impact.

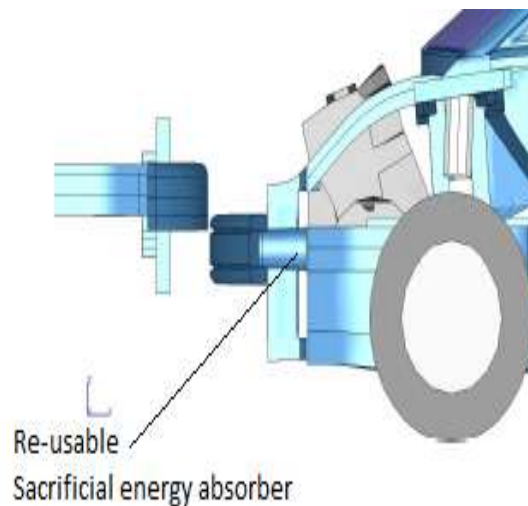

Fig1.1: Re-usable sacrificial energy absorber

Once impact takes place the system displaces the front bumper such that the spring inside damper is deflected to 90% of free length when the sacrificial damper valve is actuated to release the oil which is at pressure above the cracking pressure of valve and thus this action will action like a energy - absorber and thus the momentum force is properly dissipated without damaging the inner components of the car.

1.1 Construction

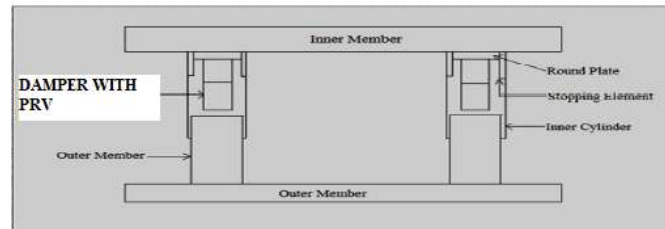

Fig1.1: Concept of Project

Proposed design of safety impact guard should include:

A. Inner Member: This member should attach to the chassis of heavy duty vehicle through the projections made by I section member. So that the height of this safety impact guard from ground level should reduce. So our first aim should be completed i.e. reduce the ground clearance of safety impact guard to avoid under ride crashes. As this member is attached to chassis of heavy duty vehicle so the effect of impact is negligible on chassis. Therefore the Inner member and chassis act as rigid member. The overall effect of impact on heavy duty vehicle is negligible.

B. Inner Cylinder: This attached to the inner member. These consist of crushing damper element, round plate, pressure relief valve the diameter of inner cylinder should be more than the outer cylinder.

C. Pressure relief valve: Damper is the element which displaces after impact comes from the outer element. Damper element is collapsible, it employs heavy duty spring that absorbs the primary impact energy which is accounted to be 40 % of the total impact energy, then the rest amount of energy is dissipated with help of pressure relief valve.

D. Round Plate: Round plate should place inside the inner cylinder as back support. Due to round plate strength of inner member & inner cylinder increases also restricts the motion of outer cylinder going besides the inner member.

E. Stopping Element: Stopping element is added in inner cylinder to stop the motion of outer cylinder. When impact force acts on the outer member then it pushes outer cylinder which causes sliding motion between inner and outer cylinder. This impact force very large therefore to stop motion this stopping element is added.

F. Outer Member: The outer member is the element on which the impact force acts or the passenger vehicle back to the heavy vehicle crashes on this outer member.

G. Outer Cylinder: This is attached to the outer member. The impact force is transmitted through the outer cylinder to the damper element the diameter of this outer cylinder is less than the inner cylinder.

1.2 Working

Once impact takes place the system displaces the outer member towards the inner member such that the spring inside damper is deflected to 90% of free length when the prv is actuated to release the oil which is at pressure above the cracking pressure of PRV and thus this action will action like a shock absorber in automobile suspension thus the impact force is properly damped without damaging the inner member or outer member. The system resembles the safety feature of air bag so that it can be reset for next use.

2. Sizing and Selection of PRV

The function of a pressure relief valve is to protect pressure vessels, piping systems, and other equipment from pressures exceeding their design pressure by more than a fixed predetermined amount. The permissible amount of overpressure is covered by various codes and is a function of the type of equipment and the conditions causing the overpressure. It is not the purpose of a pressure relief valve to control or regulate the pressure in the vessel or system that the valve protects, and it does not take the place of a control or regulating valve. The aim of safety systems in processing plants is to prevent damage to equipment, avoid injury to personnel and to eliminate any risks of compromising the welfare of the community at large and the environment. Proper sizing, selection, manufacture, assembly, test, installation, and maintenance of a pressure relief valve are critical to obtaining maximum protection.

Types, Design, and Construction

A pressure relief valve must be capable of operating at all times, especially during a period of power failure; therefore, the sole source of power for the pressure relief valve is the process fluid. The pressure relief valve must open at a predetermined set pressure, flow a rated capacity at a specified overpressure, and close when the system pressure has returned to a safe level. Pressure relief valves must be designed with materials compatible with many process fluids from simple air and water to the most corrosive media. They must also be designed to operate in a consistently smooth manner on a variety of fluids and fluid phases. These design parameters lead to the wide array of pressure relief valve products available in the market today.

3. Result

Table -1: Load, Displacement, & Energy absorbed

Load (kg)	Drop height	Theoretical displacement	Actual displacement	Actual energy absorbed
3	0.3	0.6	0.53	7.79895
3	0.4	0.8	0.74	10.8891
3	0.5	1	0.91	13.39065
3	0.6	1.2	1.06	15.5979
3	0.7	1.4	1.24	18.2466

4. CONCLUSION

The collapsible bumper and hydraulic damper shows greater energy absorbed than the conventional system. Distance travelled after impact for the collapsible bumper and hydraulic damper is lesser than that of the conventional system. The percentage safety is more than that of conventional system. Cost is moderate. System is low on weight. System is compact. System is re-usable

REFERENCES

- [1] Machine Design ; R. S. Khurmi.
- [2] Mechanisms and linkages ; Chironis.
- [3] Design of Machine Elements ; V.B. Bhandari.
- [4] "Vibrations of a mass-spring system using a granular-material damper". R.Zalewski, P.Chodkiewicz, M. Shillor.