

# Modelling of a PMSG Wind Turbine with Voltage Control

Nitish Kumar Singh<sup>1</sup>, Dashrath Kumar<sup>2</sup>

<sup>1</sup>PG Student [Power System], Dept. of EEE, Maharishi University of Information Technology, Lucknow, U.P., India

<sup>2</sup>Assistant Professor, Dept. of EEE, Maharishi University of Information Technology, Lucknow, U.P., India

\*\*\*

**Abstract** - The study of a Wind Energy Conversion System (WECS) based on Permanent Magnet Synchronous Generator and interconnected to the electric network is described. The effectiveness of the WECS can be greatly improved, by using an appropriate control. The applications of wind energy develops much more rapidly than the other renewable resources such as solar, geothermal etc. in the 21st century. It becomes the third core energy resource following non conventional fuels as oil and chemical. Electrical energy generated by wind power plants is the fastest developing and most promising renewable energy source. The wind is a clean, free and inexhaustible energy source. The origin of wind is simple.

In this paper, the Matlab simulations of a Wind Energy Conversion System with PMSG and variable-speed wind turbine have been discussed.

**Key Words:** Wind Energy, PMSG, WECS, MPPT

## 1. INTRODUCTION

Due to the depletion of fossil fuel and the need to decrease the pollution production, utilization of wind power for electrical energy generation has been interested and received much attention all over the world. On the last decade the large scale of wind farms have been connected into electrical grid system. Global Wind Energy Council (GWEC) predicted that global wind power generation capacity will reach to 459 GW and new capacity of 62.5 GW will be added to the global total at the end of 2015 [1]. However, a large penetration of the wind generator into the grid system has significant effect on power system stability [2]-[4].

Wind power has played an important role in the history of human civilization. Wind mills (or wind turbines) have been used for at least 3000 years, mainly for grinding grain or pumping water. The wind has been an essential source of power for even longer. From as early as the 13th century, horizontal-axis wind turbines were an integral part of the rural economy and only fell into disuse with the advent of cheap fossil-fuelled engines and then the spread of rural electrification.

There are many kinds of variable speed generators used for wind turbine. According to the reference [1, 2], although doubly fed induction generator (DFIG) is more broadly used than permanent magnetic synchronous generator (PMSG) today, PMSG has some advantages which are counted as experts. Particularly, PMSG is direct drive, has slow rotation

speed, does not have rotor current, and can be used without gearbox. The high efficiency and low maintenance will reduce the cost that is the most concern to invest. However, PMSG still has some drawbacks. It needs electromagnetic field with the flexible structure, which leads to the high standard of the production as well as of the operation. Furthermore, variable speed of the generator has to be known by power inverter too. According to the continuous development of wind power technology, the efficiency of inverter device, facing some tough issues, plays an important role in the improvement of wind power generation system performance. They need to be enhanced by novel controller [3] to improve the efficiency and the reliability. Inside them, MPPT integrating with the back to back space vector PWM [4] is the advantage control novel in [3], which is used to measure the rotor speed and compare with the calculated optimal rotor speed. On the other hand, not only does the inverter take an advantage in efficiency control but also the pitch angle controller takes another important part of wind turbine. It is integrated to adjust the aerodynamic torque of the wind turbine when this study rates wind speed.

## 1.1 WIND POWER SCENARIO IN INDIA

In India, the grid connected wind power generation has now gained a high level of attention and acceptability as compared to other renewable technologies available in the country. Wind Energy installation in the country is around 8698 MW as on March 31, 2008 and around 45827 million units of electricity have been fed to the state grids. In the world raking for utilization of renewable wind energy sources India stood in the 5th place. A capacity of 8698 MW of comer projects has been installed, mainly in Tamil naydu, Kerla, Madhya Pradesh, Rajasthan, Maharashtra Bengal, Andhra Pradesh, Karnataka and largest installation of wind turbines in the Muppandal and Perungudi area near Kanyakumari in tamil Naydu with an aggregate installed cap 3847.715MW. The Union Government has drafted a model of renewable energy law to increase the target for electricity generation by renewable energy to 10% by 2010 (against 10% by 2012) and 20% by 2020 of the total power generation in the country from current level of 7.5%. the Ministry for New and Renewable Energy (MNRE) has target of 17,500 MW wind power in 11th plan by 2012. [5]

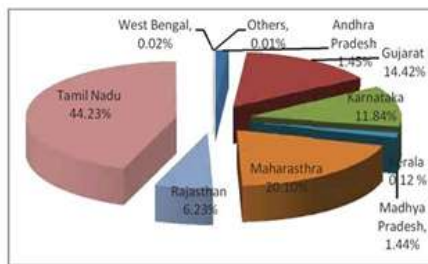

Fig. 1 pre installed capacity in State-wise

This section will present mathematical model of PMSG based on WECS. It consists of wind energy conversion, wind turbine, PMSG, converter, MPPT and inverter as show in Fig. 2.

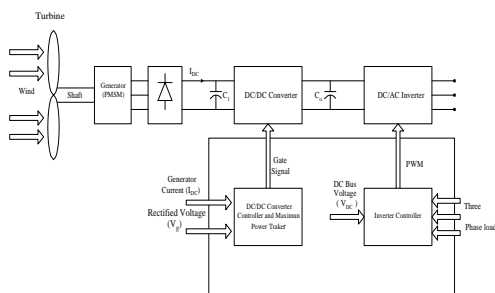

Fig. 2 wind energy conversion system

a. Wind Energy conversion:

The converted wind power is given by

$$P_w = \frac{1}{2} \rho S v^3 c_p \tag{1}$$

$v$  = wind speed,  $\rho$  = air density,  $S$  = covered surface of the turbine,  $c_p$  = conversion coefficient of power.

b. Wind turbine:

The wind turbine is used to convert the wind energy to mechanical energy. The turbine mechanical torque can be calculated from mechanical power at the turbine extracted from wind power. Then, the power coefficient of the turbine ( $c_p$ ) is a ratio between the mechanical power and wind power.

The power coefficient is a function of pitch angle ( $\beta$ ) which is the angle of turbine blade and tip speed ( $\lambda$ ), whereas tip speed is the ratio of rotational speed and wind speed which is given by

$$c_p(\lambda, \beta) = c_1 \left( c_2 \frac{1}{\lambda_i} - c_3 \beta - c_4 \beta^x - c_5 \right) e^{-c_6 \frac{1}{\lambda_i}} \tag{2}$$

The coefficients  $c_1 - c_6$  and  $x$  can be different for various turbines. They depend on the wind turbine

rotor and blade design. The parameter  $\frac{1}{\lambda_i}$  is defined as :

$$\frac{1}{\lambda_i} = \frac{1}{\lambda + 0.08\beta} - \frac{0.035}{1 + \beta^3} \tag{3}$$

The power coefficient is given by

$$c_p = \frac{P_m}{P_w}, c_p < 1 \tag{4}$$

$$P_m = c_p(\lambda, \beta) \frac{\rho S}{2} v^3 \tag{5}$$

$$T_m = \frac{P_m}{\omega} \tag{6}$$

Where

$P_m$  = the mechanical output power of the turbine,  $T_m$  = mechanical output torque.

Corresponding to real value system of the wind turbine model, wind turbine subsystem was simulated in MATLAB/SIMULINK as in Fig.3.

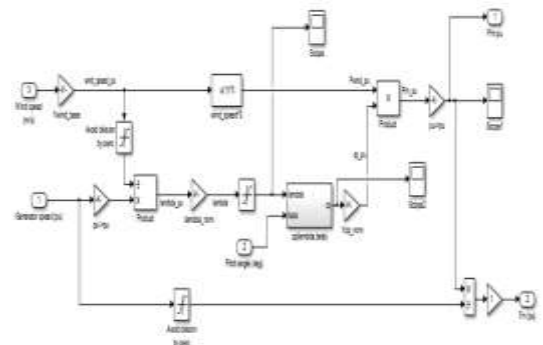

Fig. 3 MATLAB model of wind turbine

c. Permanent magnet synchronous generator (PMSG):

Consider the equivalent circuit of PMSG based on WECS as shown in Fig. 4. The model of PMSG is established in the d-q synchronous reference frame as illustrated in Fig. 4 A and Fig. 4B, respectively.

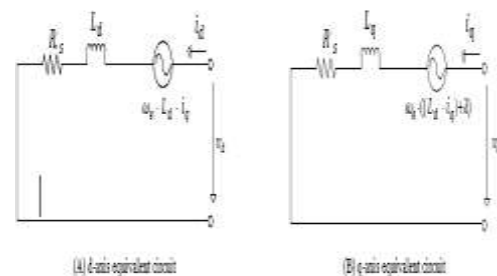

Fig. 4 Equivalent circuit of PMSG in d-q reference frame

The voltage equations of PMSG as shown in Fig. 4 are given by

$$\frac{d}{dt} i_d = \frac{1}{L_d} v_d - \frac{R}{L_d} i_d + \frac{L_q}{L_d} p \omega_r i_q \tag{7}$$

$$\frac{d}{dt} i_q = \frac{1}{L_q} v_q - \frac{R}{L_q} i_q + \frac{L_d}{L_q} p \omega_r i_d - \frac{\lambda p \omega_r}{L_q} \tag{8}$$

The electromagnetic torque equation is given by

$$T_e = 1.5p[\lambda i_q + (L_d - L_q)i_d i_q] \tag{9}$$

Where:  $L_q$  = q axis inductance,  $L_d$  = d axis inductance,  $R_s$  = resistance of the stator windings,  $i_q$  = q axis current,  $i_d$  = d axis current,  $v_q$  = q axis voltage,  $v_d$  = d axis voltage,  $\omega_r$  = angular velocity of the rotor,  $\lambda$  = amplitude of flux induced and  $p$  = the number of pole pairs.

The dynamic equations are given by [8]

$$\frac{d}{dt} \omega_r = \frac{1}{J} (T_e - F \omega_r - T_m) \tag{10}$$

$$\frac{d}{dt} \theta = \omega_r \tag{11}$$

Where  $J$  = inertia of rotor,  $F$  = friction of rotor and  $\theta$  = rotor angular.

Where  $J$  = inertia of rotor,  $F$  = friction of rotor and  $\theta$  = rotor angular.

d. MAXIMUM POWER TRACKING ALGORITHM:

Due to its monotonic characteristics wind turbines can be controlled to yield maximum power using search control methods. The model for the maximum power tracking algorithm and the dc-to-dc controller are shown in fig. 7. The embedded MATLAB function contains the software code that represents the maximum power tracker. The code is triggered at a frequency of 6 Hz, therefore running algorithm 6 times per second. Every time the code is run and the power is calculated and the controller reacts to the reference voltage commanded by the maximum power tracker.

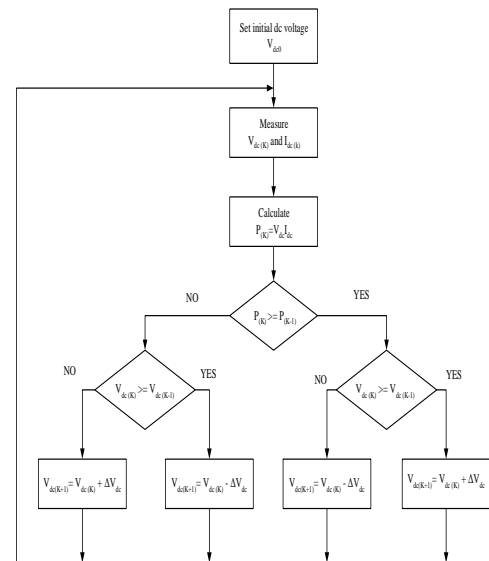

Fig. 5 MPPT Flowchart

## 2. Simulation Analysis

In order to verify the model of the whole autonomous control system design, Matlab 2010b is used to simulate this system design in Figure 6. Model of wind turbine is in wind turbine; models of control system of generator-side inverter and grid-side inverter are included in Subsystem 1 and Subsystem 2. The MPPT controller and PI controller are also included in Subsystem 1 and Subsystem 2. The pitch angle controller is completely modelled in wind turbine. In this simulation, the wind turbine PMSG model obtains the wind speed and provides an optimal reference speed to control the system. The simulation results are shown in Figures 7-10

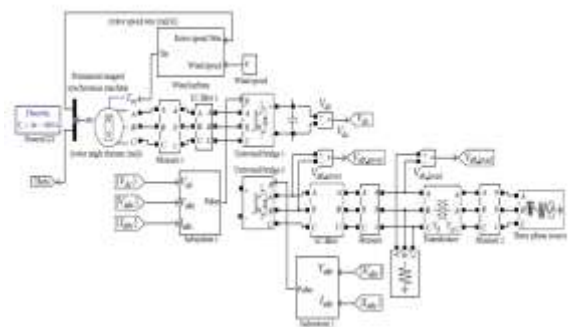

Fig. 6 wind turbine PMSG model

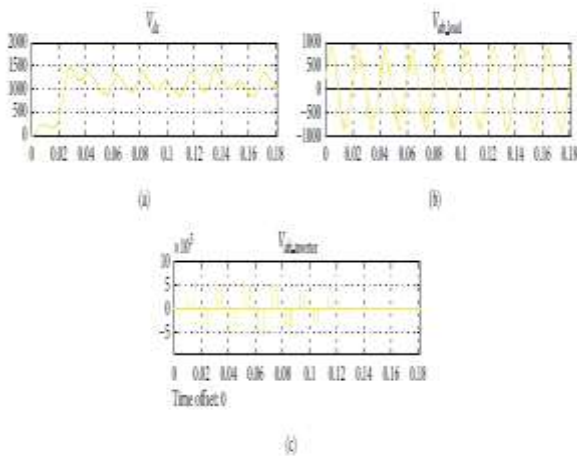

Fig. 7 DC-link voltage, load voltage, and inverter voltage

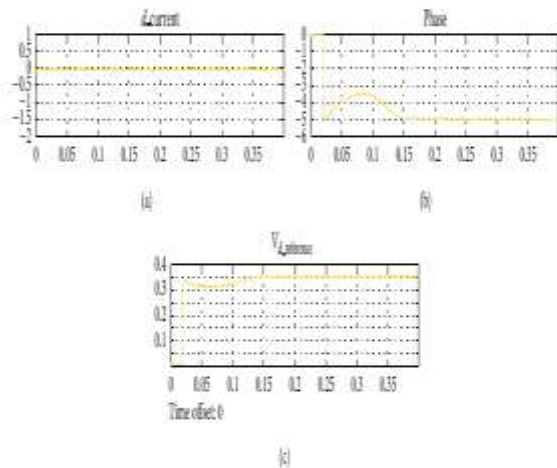

Fig.8 *d*-current, voltage phase of PMSG, and *d*-voltage reference (pu)

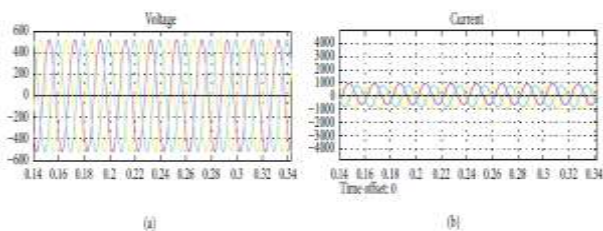

Fig.9 Three-phase voltage and current of the grid

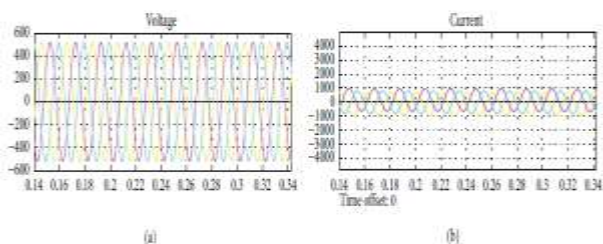

Fig. 10 Active and reactive power

### 3. Conclusions

This study analyzes the control strategies as well as models and designs and simulates the whole autonomous system of PMSG wind turbine feeding AC power to the utility grid in Matlab Simulink 2010b. The simulation results show that the combination of pitch angle controller, generator-side inverter controller, and grid-side inverter controller has good dynamic and static performance. The maximum power can be tracked and the generator wind turbine can be operated in high efficiency. DC-link voltage is kept at stable level for decoupling control of active and reactive power. Hence, the output will get the optimum power supply for the grid.

### 4. References:

1. TThe Global Wind Energy Council (GWEC), Global wind report 2010, April 2011. [Online]. Available: <http://www.gwec.net/>.
2. TR. Doherty, E. Denny, M. O'Malley, "System operation with a significant wind power penetration," IEEE Power Engineering. Summer Meeting, vol. 1, pp. 1002–1007, Jun. 2004.
3. KK.S. Salman, A.L.J. Teo, "Windmill modeling consideration and factors influencing the stability of a grid-connected wind power-based embedded generator," IEEE Trans. Power Syst. vol. 18, no. 2, pp. 793–802, May 2003,.
4. NN. Dizdarevic, M. Majstrovic, S. Zutobradic, "Power quality in a distribution network after wind power plant connection," IEEE Power Syst. Conf. Expo., vol. 2, pp. 913–918, Oct 2004.
5. <http://www.windpowerindia.com>
6. R. Datta and V. T. Ranganathan, "A method of tracking the peak power points for a variable speed wind energy conversion system," IEEE Transactions on Energy Conversion, vol. 18, no. 1, pp. 163–168, 2003.
7. AA. M. De Broe, S. Drouilhet, and V. Gevorgian, "A peak power tracker for small wind turbines in battery charging applications," IEEE Transactions on Energy Conversion, vol. 14, no. 4, pp. 1630–1635, 1999.
8. QO.Wang and L. Chang, "Independent maximum power extraction strategy for wind energy conversion systems," in Proceedings of the 1999 IEEE Canadian Conference on Electrical and Computer Engineering, vol. 2, pp. 1142–1147, May 1999.

9. FF. Iov, A. Hansen, P. Sorensen, and F. Blaabjerg, Wind Turbine Block Set in Matlab/Simulink, Aalborg University and RISO, 2004.
10. AA. Rol'an, A. Luna, G. V'azquez, D. Aguilar, and G. Azevedo, "Modeling of a variable speed wind turbine with a permanent magnet synchronous generator," in Proceedings of the IEEE International Symposium on Industrial Electronics (ISIE '09), pp. 734–739, July 2009.
11. XX. Yuan, F. Wang, D. Boroyevich, R. Burgos, and Y. Li, "DClink voltage control of a full power converter for wind generator operating in weak-grid systems," IEEE Transactions on Power Electronics, vol. 24, no. 9, pp. 2178–2192, 2009.
12. MM. Yin, G. Li, M. Zhou, and C. Y. Zhao, "Modeling of the wind turbine with a permanent magnet synchronous generator for integration," in Proceedings of the 2007 IEEE Power Engineering Society General Meeting, pp. 1–6, June 2007.