

## SOLAR VEHICLE

Krunal. J. Gandhi<sup>1</sup>, Dipak B. Jadhav<sup>2</sup>, Avinash S. Shirsath<sup>3</sup>, Prashant U. Badgujar<sup>4</sup>,

Vijay S. Samudre<sup>5</sup>, Nikhil K. Bagul<sup>6</sup>

<sup>1</sup>Assistant prof., Dept. of Electrical Engineering, D. N. Patel College Of Engineering, Shahada, Maharashtra  
<sup>2,3,4,5,6</sup>UG Student, Dept. of Electrical Engineering, D. N. Patel College Of Engineering, Shahada, Maharashtra

\*\*\*

**Abstract** - The renewable energy is important for today's world as in close to future the non-renewable sources that we tend to area unit victimization area unit progressing to get exhausted. The solar vehicle may be a step in saving these non-renewable sources of energy. The essential principle of solar automotive is to use energy that's hold on during a battery throughout and once charging it from a solar array. The charged batteries area unit wont to drive the motor that serves here as an engine and moves the vehicle in reverse or forward direction. The electrical sound resistor is provided therefore on management the motor speed. This avoids excess flow of current once the vehicle is meant to be stopped suddenly because it is in traditional cars with regards to fuel. This idea, in future, could facilitate defend our fuels from obtaining destroyed.

**Key Words:** Renewable energy, solar vehicle, solar automotive, electrical sound resistor, motor speed

### INTRODUCTION

Energy is one amongst the foremost important wants for human survival on earth. We tend to area unit hooked in to one kind of energy or the opposite for fulfilling our wants. One such kind of energy is that the energy from fossil fuels. We tend to use energy from these sources for generating electricity, running cars etc. However the most disadvantages of those fossil fuels area unit that they area not environmental friendly and that they are exhaustible.

To affect these issues of fossil fuels, we'd like to seem at the non-conventional sources of energy. With relevancy this idea we've got designed an Electrical vehicle that runs on alternative energy. At one hand, there area unit a lot of cars or motorcars area unit dominating the transport medium, on the opposite hand these cars area unit being dominated by the fuel. As a result, the restricted resources area unit being quashed by the producers and dealers to satisfy this would like that is leading USA to an unsure future with having the scarceness of fuel and minerals. This project is especially designed to make solar and electrical power-driven automotive that's fully eco-friendly because it doesn't emit any harmful gases.

The bigger community on energy and its applications, additionally on build a sensible solar and

electrical power-driven auto motive victimization regenerate the facility that would have universe application upon more

technological advances. This project includes a robust need to introduce and use native technology and resources. Since fuel and diesel isn't needed, it uses alternative energy that is overabundant in nature and economical. The vehicle designed may be a four wheel drive and might be used for shuttle and short distances.

As these vehicles type the long run of the automotive trade, we'd like to think about rising their style and creating them value effective. This vehicle is an initiative during this direction.

### REVIEW OF LITERATURE

It is necessary to grasp alternative energy assortment and its conversion into electricity, analysis of electrical performance, and therefore the current efforts being created to boost conversion potency. It absolutely was additionally necessary to look at the particular impact of the colour filters on the sunshine input into the panel. The first material utilized in the trendy assortment of alternative energy is semiconductor. Albeit it takes a hundred times a lot of expanse of semiconductor than that of alternative solid-state materials to gather a similar quantity of energy, semiconductor was already developed and in production once alternative energy assortment technology was developed, then it absolutely was the sensible choice[1]. Potency is that the quantitative relation of total energy input into a machine or alternative system to the entire energy output ( $e = \text{helpful energy output} / \text{energy input}$ ). Alternative energy assortment potency has improved because the general technology has improved, growing from the primary passive assortment ways (efficiency approx. 1%) to the present applicable ways (efficiency approx. 15-20%) [2].

In the conversion inside the panel from daylight to electricity, potency can rise if the panel will operate at higher temperatures. traditional panels use a double cycle conversion process; Kribus (2002) introduces a triple cycle, the primary of that operates at extraordinarily high temperatures. it's referred to as a magneto-hydrodynamic (MHD) cycle, and might operate at temperatures within the vary of 2000° - 2500°, up from the present limit of regarding 1300°. A panel with hyperbolic potency, probably approaching half-hour, that's still possible for mass production [4]. His style uses a special quite semiconductor, referred to as Czochralski semiconductor, with oblique gaseous contacts (OECO). The contact points area unit metalized victimization cheap metal and obliquely gaseous employing a terribly easy four-step method that will

convince be possible for production. These enhancements being created within the technology area unit extraordinary, however man unless they'll be place to sensible use. Why ought to scientists hassle with all the hassle of rising energy assortment ways once the globe is already quite pleased with its current energy supply? clearly, fossil fuels can solely last farewell, and alternative energy is rising because the heir-apparent to the oil family, because the best option economically and ecologically [5].

The energy consumption of a median room was discovered victimization similar techniques to the current study, however on a bigger scale, and it absolutely was determined that the entire energy [6].

### CIRCUIT DESCRIPTION

The on top of diagram shows the entire circuit implementation with part interfacing with the microcontroller. during this system we've got used Atmega328P microcontroller for dominant purpose. The system works victimization electrical power provide provided by the battery connected within the circuit. this can be a 12V reversible battery which can be charged by the alternative energy victimization solar panels. In this system the solar array is employed to convert daylight in electrical power and hold on within the battery.

For this the output of the solar is connected to the battery through a diode. This battery stores the facility and fed to the motors as per the need. The microcontroller and alternative circuit parts need regulated 5V provide.

The input to the regulator is provided at pin no one of the regulator and therefore the output is taken out from pin no three of the regulator. The pin no two of the regulator IC is grounded. The 5v from regulator IC is provided to the controller and alternative parts. The electrical condenser at the input and therefore the output of the regulator is employed to get rid of the ripples within the signal i.e., this area unit filter electrical condenser. The 5v provide to the controller is provided at pin no seven, twenty and twenty one and therefore the pins eight and twenty two area unit grounded. A reset switch is connected at pin no one of the Atmega328 microcontroller. once the reset switch is ironed it bypass the provision from pin no one of the controller to the bottom. Therefore the controller gets reset.

As this switch is employed to reset the controller this switch is termed reset switch. A resistance is additionally connected to the pin one of controller. A crystal of 16MHz with 2 capacitors is connected at pin no nine and ten that forms a quartz oscillator. This generator provides machine cycle to the controller on that the controller operates. The system consists of four DC motors wont to move the automotive in desired direction. . The system consists of four DC motors wont to move the automotive in desired direction. The 5v from regulator IC is provided to the controller and alternative parts. The electrical condenser at the input and therefore the output of the regulator is employed to get rid of the ripples within the signal.

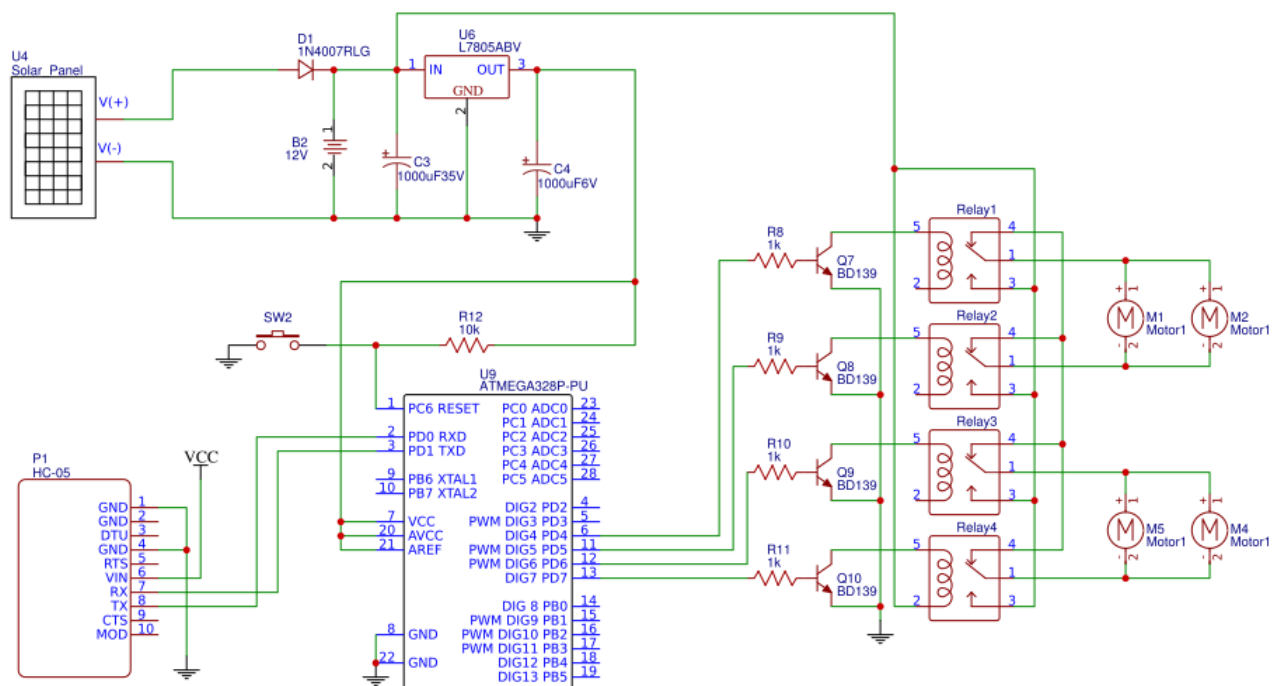

These DC motors area unit interfaced with the microcontroller to control it through the microcontroller. These motors area unit interfaced with the controller through relay circuits as shown within the circuit diagram of the system. to show these relay ON and OFF transistors (BD139) area unit used that area unit triggered by the controller to control the relay through that the motor can begin rotating and therefore the automotive can move. These DC motors area unit sixty rate motors utilized in this method. The transistors wont to operate the relay area unit connected to four pins in port D of the controller IC. the bottom terminals of the transistors area unit connected with the controller through 1K resistors. And at the collector terminal the relays area unit connected to every junction transistor as shown within the circuit diagram. during this system we've got used 12V relays. The 12V provide for these relays is provided by the battery within the system. At the output terminals of the relays motors area unit connected to maneuver the automotive. The automotive are going to be controlled remotely through a Bluetooth module interfaced during this system. Here a HC-05 Bluetooth module is employed as shown within the circuit diagram. This Bluetooth is connected in port D as shown within the circuit diagram.

The transmitter terminal of the Bluetooth module is connected to the receive pin of the controller IC whereas the receiver pin of the Bluetooth is connected to the transmitter for serial communication. The Bluetooth module receives the signal send by the user through mechanical man app designed victimization Bluestick Controller application.

## WORKING

In this project we've got planned an economical and eco-friendly solar energy automotive for folks travel an exact quantity of distance each day, for example, the workplace commuters in town. The solar array utilized in the solar vehicle is of the rating of one hundred forty WP. the most purpose that ought to be unbroken in mind where as creating a star vehicle is that the mounting of the solar array.

The panel ought to be mounted in such the simplest way that it receives most sun rays so it offers its most potency. For the vehicle designed, we've got mounted the solar array on the highest of the bus roof. we've got used the traditional roof-top mounting technique for the solar array. Sun is that the main supply of energy for the vehicle.

Energy from Sun is captured by the star panels and is regenerate to electricity. The electricity therefore fashioned is being fed to the batteries that get charged and is employed to run twenty four V DC series motor. The shaft of the motor is connected to the rear wheel of the vehicle through chain sprocket.

The batteries area unit ab initio totally charged and thenceforth they're charged by panels. This helps in finishing the charging-discharging cycle of the batteries, that is incredibly necessary for correct operating of batteries.

## ADVANTAGES

- in contrast to regular cars, alternative energy power-driven cars area unit ready to utilize their full power at any speed.
- solar power-driven cars don't need any expense for running.
- solar cars turn out less noise.
- solar cars essay to maintenance.
- solar cars turn out no harmful emissions.

## DISADVANTAGES

- solar cars don't have speed or power that regular cars have.
- Solar power-driven cars will operate just for restricted distance.
- If there's no daylight.
- If it's dark out for several days, the lead-acid accumulator won't charge and this may be a tangle. this can be the most reason why folks don't admit solar cars.

## CONCLUSION

The solar vehicle solves several issues associated with the setting and is that the best pollution free technique. we'd like to form use of them so we are able to cut back our dependence on fossil fuels. solar vehicles do have some disadvantages like tiny speed vary, initial value is high. Also, the speed of conversion of energy is not satisfactory. however these disadvantages are often simply overcome by conducting more analysis during this area; just like the drawback of solar cells are often resolved by victimization the immoderate economical star cells that provide regarding 30-35% potency. It is to be noted that the battery charge can solely be depleted once the motor is driving the automotive. Therefore throughout the time once the automotive is halted at traffic (unlike an indoor combustion engine {which can which which is able to} waste fuel) the batteries of the automotive will really get charged by the star exposure therefore increasing the cars mileage.

## FUTURE SCOPE

A solar vehicle is an electrical vehicle high power utterly or considerably by direct alternative energy. Usually, electrical phenomenon cells contained in solar panels convert the solar energy direct into electrical energy. the term "solar vehicle" typically implies that alternative energy is employed to power all part of a vehicles propulsion star vehicle don't seem to be sold out as sensible day after day transportation devices at the moment, however area unit area unit primarily demonstration vehicles and engineering exercises, typically sponsored by government agencies.

## REFERENCES

- [1]. D. Metz, mechanical engineering 1983, 105(1), 80-82. "SOLAR VEHICLES AND BENEFITS OF THE TECHNOLOGY", by John Connors, ICCEP paper 2007.
- [2]. J. Connors, "On the subject of solar vehicles and the benefits of the technology," in Proc. ICCEP'07, 2007.
- [3]. Intelligent solar powered automobile-ventilation system," Applied Energy, vol. 80, pp.141-154, 2005.
- [4]. K. D. Huang, S.-C. Tzeng, W.-P. Ma, and M.-F. Wu, "5. Rizzo, G. (2010), Automotive Applications of Solar Energy, IFAC Symposium Advances in Automotive Control, July 12 - 142.
- [5]. Renewable Energy, Solar Energy  
[http://en.wikipedia.org/wiki/renewable\\_energy\\_solar\\_energy](http://en.wikipedia.org/wiki/renewable_energy_solar_energy).
- [6]. Mohammad Asadul Hagu and Jabalpur Rahman, "Power Crisis and Solution in Bangladesh" Bangladesh J. Sci. Ind. Res. 45(2), 155-162, 2010 Power and Energy Sector Road Map : An Update, June 2011
- [7]. How Wind shield Wipers work, <http://auto.howstuffworks.com/wiper.htm>, (Last Visited 22) January, 2014.