

High Frequency C Arm: New Era in Real Time Imaging Manufactured by ADONIS

Manpreet Kaur

Adonis Medical Systems Private Limited, Mohali (INDIA)

Abstract - ADONIS is a professionally managed Private Limited Company and is located in North of INDIA with Its manufacturing Base at Mohali an Industrial Town in Punjab, India. ADONIS has a complete set up of Sales cum Service Network in various parts of the country for promotion and maintenance of its products. ADONIS High Frequency 50 kHz, Stationary Anode, 3.5 kW Mobile Surgical C-Arm for Mobile Fluoroscopic Applications incorporating many performance advances that provide a new level of efficiency, system, reliability and simplicity of operations. The system is designed to meet a wide range of functional needs in Urology operations. This paper provides an extensive overview of mobile surgical C-Arm including technical specifications, composition etc.

Key Words: ADONIS; X-ray Machine; Mobile Surgical C-Arm

1. INTRODUCTION

ADONIS Medical Systems Private Limited, have rich experience of Manufacturing of Medical Equipment's with dynamic and professional work force. It is located in North of INDIA with Its manufacturing Base at Mohali an Industrial Town in Punjab. We're continually developing new diagnostic imaging technology that saves lives, and helping hospitals meet the growing demand for high-quality, medical services at prices patients can afford. Our new product introductions, growing services offerings & information technology comprise our foundation for the next century. ADONIS provides its customers with true latest technology yet so Cost Effective. ADONIS has manufactured First Auto programmable and completely Electronic Model in the country keeping in mind the worldwide standard and features with safety and reliability. ADONIS is an ISO 9001:2000 & ISO 13485: 2003 certified Company and also certified by Bureau of Indian Standards (BIS) for Mechanical and Electrical Safety shown in figure 1.

All ADONIS X-Ray Machines are approved by Atomic Energy Regulatory Board (AERB) for Radiation Safety. Our company deals with the manufacturing of X-rays machines and we distribute it within the whole world. ADONIS Mobile C-Arms are used for X-ray guidance during procedures in Orthopedics, Urology, and Cardiology, Neurology etc. for faster and more accurate Evaluation of surgical parameters. The ADONIS mobile C Arms are categorized into three categories: Platinum View, Gold View, and Diamond View.



Figure 1: ADONIS C Arm Real Image

1.1 New Series of ADONIS C Arm

Platinum View is Arm is a High end C Arm for Neurology applications and it is upgradeable to interventional settings.

Gold View is reliable and confident choice for beginners and designed for basic needs in OT.

Diamond View is ideal for Urology and Orthopedics applications with a combination of high resolution CCD camera with medical grade monitors and DIP system of technically matched high resolution optical path.

Table 1: Parameters of ADONIS C Arm

Series/Parameter	Platinum View	Diamond View	Gold View
Image intensifier	12"/9" (Triple Field), 25mm	9" (Triple Field), 25mm	9" (Triple Field), 23mm
CCD Camera	More than 1 million pixels with high resolution optical path	High resolution CCD Camera with high resolution path	High resolution CCD Camera with high resolution path
Monitors	19" monochrome medical monitors	19"/17" monochrome medical monitors	19"/17" LED monitors
Software /Storage	RAPIDS with storage of >25000 images	RAPIDS with storage of >20000 images	RAPIDS with storage of >10000 images
APR in Fluoro	Available	Available	Available
APR in RAD	Available	Available	Not Available
ADR in Contral	20kV/ Sec	10kV/ Sec	10kV/ Sec

	variations	variations	variations
Mobile trolley	Modulator with high adjustment through actuator	Modulator with high adjustment through actuator	Modular

The table 1 explains the parameters of ADONIS C Arm and Figure 1 describes the schematic layout of the C arm along with mechanical movements: vertical (Motorized): 45 cm, horizontal: 22Cm, Rotation +/- 180 Degree, Swinging: +/- 12.5 Degree, orbital travel :120 degree, clearance: 855mm

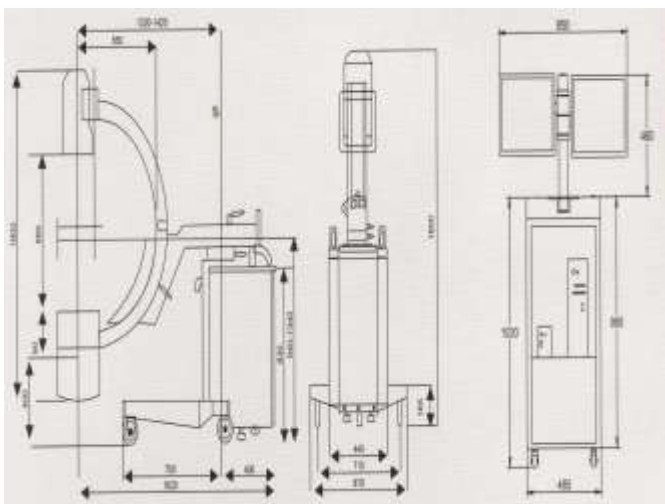

Figure 1: Schematic Diagram of C Arm

2. HIGH FREQUENCY C ARM (EXPORT MODEL) FEATURES

- More than 10000 Images storage facility
- Cordless Remote for Image Processing Functions
- Medical Grade LED Monitors
- Live, LIH, Rotation, Flip, Mirror, Negative, Image Measurement
- Zoom, CD/DVD/Pen Drive storage, Printing etc.
- Accurate Vertical Movement through Silent Actuator
- Soft Horizontal Movement through Sliders
- Cable Guard on Wheels
- Cassette Holder
- Digital Display for mAs, kVp, Technic, X-Ray ON & Overload Protection
- Independent kVp, mA, mAs Techniques for better radiographic and fluoroscopic results.
- Microprocessor based system for accurate time selection for exposure with ADC Mode
- Automatic Overload protection with visual & audible indication for longer life of the Tube
- Single step kVp selection. Single step mAs selection.
- Soft Touch keys for mAs selection, mA selection, Radiography/ Fluoroscopy selection & exposure
- Temperature controlled Tube Protection for longer life of the Tube with Digital Display of Temperature
- Software Controlled Collimation without Radiation (Off Line)

3. COMPARISON BETWEEN ADONIS AE-60 HFS AND ADONIS AE HF 9060

Table 2: Comparison between Adonis AE-60 HFS and Adonis AE HF 9060

Technical Specifications	AE-60 HFS	ADONIS AE HF 9060
Type of Generator	50 KHz, High Frequency	50 KHz, High Frequency
Tube type	Double focus stationary anode	Double focus Rotating anode
Focal spot	Small focus: 0.6mm X 0.6mm Large Focus: 1.5mm X 1.5mm	Small focus: 0.3mm X 0.3mm Large Focus: 0.6mm X 0.6mm
Fluoroscopic kVp	40-110 kVp (Single Step)	30-120 kVp (Single Step)
Normal Fluoroscopy	0.1-0.3 mA	0.1-0.4 mA
HD Fluoroscopy	3.0-6.0 mA	3.0-6.0 mA
Radiographic kVp	Temperature controlled (5 min. cumulative)	Temperature controlled (5 min. cumulative)
Radiographic mAs	40-110 kVp (Single Step)	40-110 kVp (Single Step)
Radiographic Timer	Up to 220 mAs	Up to 220 mAs
Radiographic Exposure	75 mAs	80 mAs
Automatic Dose Rate	ADR control is provided	ADR control is provided
Display	LED/LCD	LED/LCD
Power Requirement	220V /50Hz, 3.5 KW, Single Phase	220V /50Hz, 6.0 KW, Single Phase

3. MEMORY FEATURES

IMAGE MEMORY: Computer Based Processing and Memory System with option to hold Last Image with following image processing functions available in computerized workstation. Pulsed Mode, Live Mode, Recursive Filter, Contrast Enhancement, Negative Image, Zoom both in Horizontal & Vertical Direction, Mirror Images, Upside Down Image etc. Large Data Image Storage Facility both in Frame by Frame mode and in Movie mode, Added DVD writer for recording on the CD/DVD, USB device to take data on PEN Drive.

In built Computer Attachment Facility: PC as a standard feature for storing large data of information both in picture to Picture basis or in movie mode. Added software package for maintain customer records and possible print out on customer printer on paper through customer's computer. Memory Functions are operable through Cordless Remote without disturbing the Control Panel.

It is dedicated with Individual Software Settings for different Surgeries. It also provides complete Patient data base with complete details of surgery. The capacity of the equipment

storage: 50 Temporary Images and more than 10,000 images in permanent mode.

4. CONCLUSION

This paper provides an extensive overview of mobile surgical C-Arm including technical specifications, composition etc. the mobile surgical C-Arm is used for X-ray guidance during procedures in orthopaedics, Urology, Cardiology, Neurology etc. for faster and more accurate evaluations of surgical parameters.

REFERENCES

- [1] Berger, M., Yang, Q., & Maier, A. (2018). X-ray Imaging. In *Medical Imaging Systems* (pp. 119-145). Springer, Cham.
- [2] Ritter, D., Orman, J., Schmidgunst, C., & Graumann, R. (2007). 3D soft tissue imaging with a mobile C-arm. *Computerized Medical Imaging and Graphics*, 31(2), 91-102.
- [3] Fahrig, R., Butts, K., Rowlands, J. A., Saunders, R., Stanton, J., Stevens, G. M., & Pelc, N. J. (2001). A truly hybrid interventional MR/X-ray system: Feasibility demonstration. *Journal of Magnetic Resonance Imaging: An Official Journal of the International Society for Magnetic Resonance in Medicine*, 13(2), 294-300.
- [4] Sati, M., & Cyr, M. (2006). U.S. Patent No. 7,065,393. Washington, DC: U.S. Patent and Trademark Office.
- [5] Isaacs, R. E., Johnston, S. M., Skwerer, D. A., & Campbell, R. G. (2018). U.S. Patent Application No. 10/139,920.
- [6] (Hughes, J. (2018). *Introduction to Intra-operative and Surgical Radiography*. Oxford University Press.
- [7] Isaacs, R. E., Johnston, S. M., Skwerer, D. A., & Campbell, R. G. (2018). U.S. Patent Application No. 15/713,265.
- [8] Zhou, O. Z., Lu, J., Shan, J., Tucker, A., Chtcheprov, P., Platin, E., & Wu, G. (2018). U.S. Patent No. 9,907,520. Washington, DC: U.S. Patent and Trademark Office.