

# Effect of Horizontal Perforated Baffle on Sloshing in Partly Filled Tank Trucks

Umer Abdullah Siddiqui<sup>1</sup>, Bushra Fatima<sup>2</sup>, Haseeb Uddin Siddiqui<sup>3</sup>, Muhammad Hammad<sup>4</sup>

<sup>1,3,4</sup>Dept. of Mechanical Engineering, NED University of Engineering & Technology, Karachi, Pakistan

<sup>2</sup>Lecturer, Dept. of Mechanical Engineering, NED University of Engineering & Technology, Karachi, Pakistan

\*\*\*

**Abstract** - The effect of a horizontal perforated baffle on sloshing is investigated for a single chamber of a tank truck under different fill levels. During the braking and sudden evading maneuver, the effect of fluid impact further carried on by sloshing can be detrimental rather than alleviating the distress of an imminent danger ahead. As the load shifting easily occurs in partly filled fluid containing tanks, when accompanied by a dynamic impact, it escalates a roll over moment and disrupts the linear fashioned braking of a tank truck. Tank trucks that carry dangerous fluids possess far greater danger as a rollover can result in a blast. Transient analysis is performed for models with and without a horizontal perforated baffle integrated inside the chamber of a tank truck with Volume of Fluid (VOF) technique in Ansys CFX software. In order to visualize the behavior of fluid under such scenarios, a time series analysis is carried out for tracking free surface, pressure change, center of gravity shift and the response of oscillations of fluid inside the chamber.

**Key Words:** Sloshing, Tank truck, Perforated, Baffle, CFD

## 1. INTRODUCTION

Sloshing is defined as the oscillation of fluid with an unrestricted free surface. With sudden deceleration imposed by braking, a rise of fluid height occurs with an inertia or a dynamic component hence rigorous sloshing occurs in the chamber of a tank truck. In tank trucks that may carry fluids such as fuels, chemicals or simply water may encounter a situation when they remain partly filled for the remaining journey; it is the condition when the chances of rollover increase dramatically. A report of highway accidents involving heavy vehicles suggested that tank trucks were 4.8 times more likely to be involved in rollovers [1]. Another US study reported that the average annual number of tanker rollovers is about 1265, which accounts for 36.2% of the total number of heavy vehicle highway accidents [2]. In cases of partly filled tank trucks, sloshing can yield a roll moment of up to 1.57 [3]. Furthermore, it causes severe stability and directional loss, hence for this very reason various kinds of baffles and the effect of their shapes on dampening the sloshing have been studied [4-7]. However, to date not much light is shed on the horizontal type and this paper aims to elucidate their effect on sloshing in a single chamber of a tank truck under different fill levels. The need of an effective baffle is of vital importance as without it the braking of the tank truck will not be smooth and stable fashioned, due to

the oscillations caused by sloshing of the fluid that results in friction with varying modes [8, 9].

## 1.1 Methodology

The effect of sloshing is contemplated for a horizontal perforated baffle integrated into a chamber of a tank truck. Yan modelled longitudinal fluid slosh within a tank containing baffles using the Navier-Stokes equations coupled with the volume-of-fluid (VOF) equation in Ansys Fluent [10], similarly Bautista used Navier-Stokes equation and standard  $k-\epsilon$  turbulence model [4]. Sajid used the same (VOF) approach [7],

$$\phi = V\phi_2 + (1 - V)\phi_1$$

where  $\phi$  is the volume averaged quantity,  $V$  is the liquid volume fraction,  $\phi_1$  &  $\phi_2$  are fluid 1 phase and fluid 2 phase respectively, algorithm based on this equation is used in Ansys CFX with  $k-\epsilon$  turbulence model to solve the multiphase flow. Analysis was performed for fill levels ranging from 30% to 90 % with increments of 20%.

## 2. DESIGN PARAMETERS

The shape of the chamber is elliptical which is the most common for tank trucks, similar to the aspect ratio that Kolaei used [11], with dimensions of the chamber similar to as Shimanovsky used [12]. Table 1 shows the dimensions.

**Table-1:** Design model dimensions

Height (m)	2.04
Width (m)	2.5
Length (m)	1.5

The perforated baffle is flat and laid normal to the bulkheads exactly in the center at 50% height from the base of the chamber. Kolaei considered vertically center mounted baffle to be effective for damping lateral slosh [13]. Since the cross section of the chamber is maximum at the center, it is the section where the most powerful sloshing could occur, as it has enough filled mass to easily destabilize the tank truck. At this position the perforated baffle could yield better damping results for most fill levels. The baffle plate has 7

holes in a column and 3 rows totaling up to 21 holes with a diameter of 0.2m, integrated in the chamber of volume 6 m<sup>3</sup>.

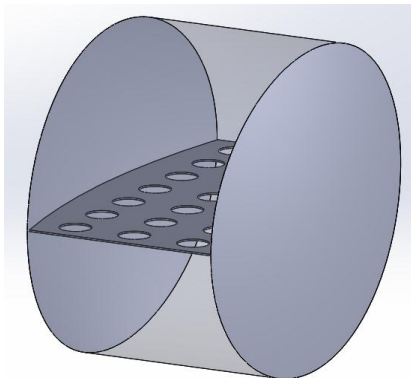

Fig -1: CAD model of Design

### 2.1 Boundary conditions

An optimum deceleration of 5m/s<sup>2</sup> [6, 14] was applied for time 0 < t < 3 seconds in the longitudinal direction with gravity of 9.81m/s<sup>2</sup> applied constant throughout. Fluid temperature was 25 °C, fluids densities were 1.225kg/m<sup>3</sup> and 998 kg/m<sup>3</sup> respectively for air and water, initial fluid velocity as x = 0 m/s, y = 0 m/s, z = 0 m/s at 1 atm pressure inside the chamber was applied. Time step size used was 0.04s [6] to ensure accuracy. The simulation was carried out till 5 seconds to completely contemplate the effect from the application of brakes to completely coming to a halt.

### 2.2 Mesh structure

The mesh used was fine with high resolution. The number of nodes for baffled & un-baffled chamber were 52013, 34339 respectively and were kept consistent throughout.

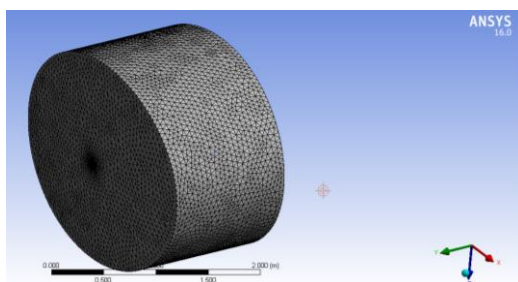

Fig-2: Mesh structure

## 3. RESULTS AND DISCUSSION

Free surface tracking was done by Isosurface and water volume fraction results. Time series results from Figures 3 to 12 show that for 30% fill level the fluid first pierced through the perforated baffle at 0.32 seconds, for 50% fill level at 0.16 seconds, which is the fastest of all since the free surface of the fluid lies at the level of perforated baffle. Hence, for

rising fill levels the time for the fluid to pierce through the baffle increased. This is because the volume of fluid sitting over the baffle needs some time to shift, in order to allow the fluid below to pierce through. For 70% and 90% fill levels, it was 0.32 seconds and 0.48 seconds respectively.

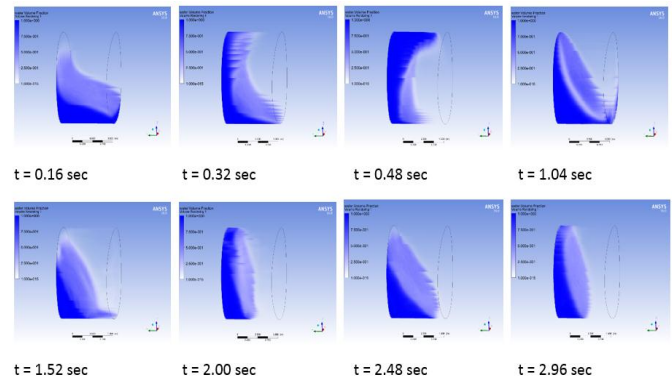

Fig-3: Time series results of volume fraction for 30% fill level in chamber without perforated baffle.

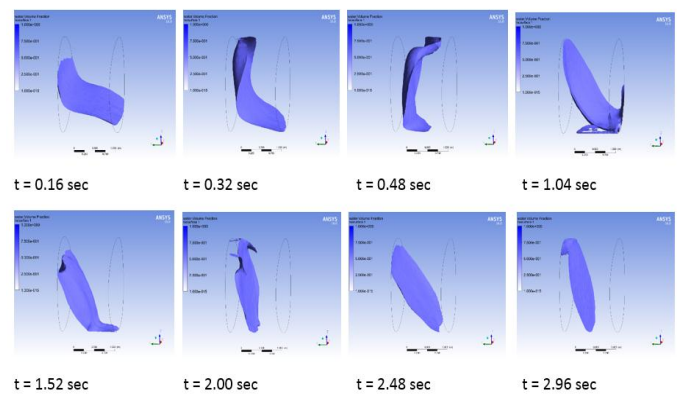

Fig-4: Time series results of free surface position for 30% fill level in chamber without perforated baffle.

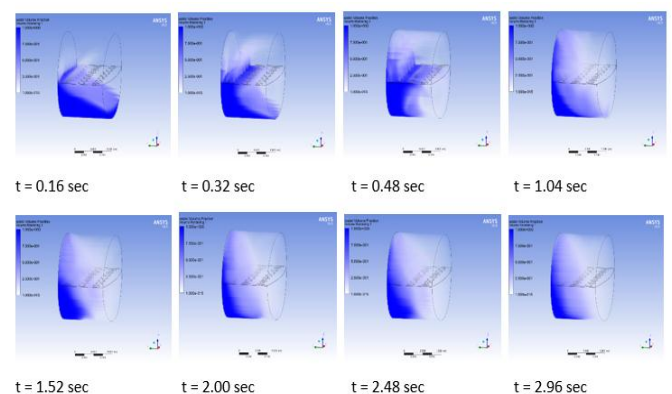
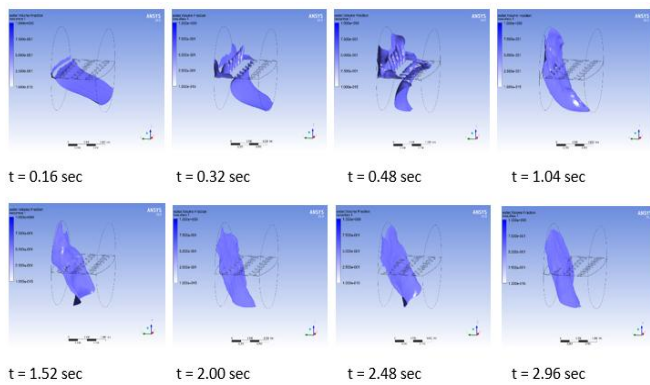
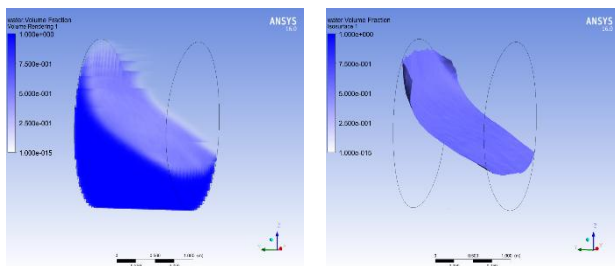

Fig-5: Time series results of volume fraction for 30% fill level in chamber with perforated baffle.



**Fig-6:** Time series results of free surface position for 30% fill level in chamber with perforated baffle.



**Fig-7:** Volume fraction & free surface of fluid at 50% fill level in chamber without baffle at t=0.16 sec.

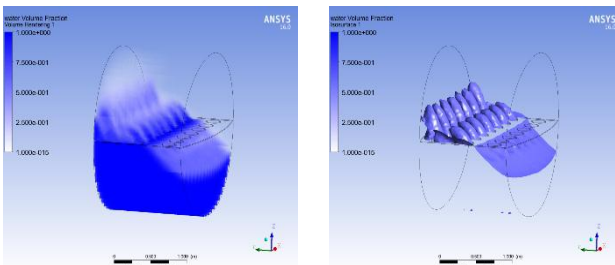

**Fig-8:** Volume fraction & free surface of fluid at 50% fill level in chamber with baffle t=0.16 sec.

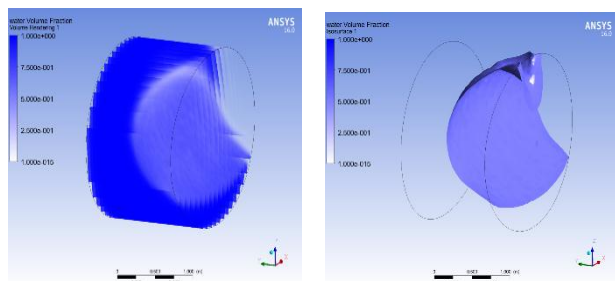

**Fig-9:** Volume fraction & free surface of fluid at 70% fill level in chamber without baffle t=0.32 sec.

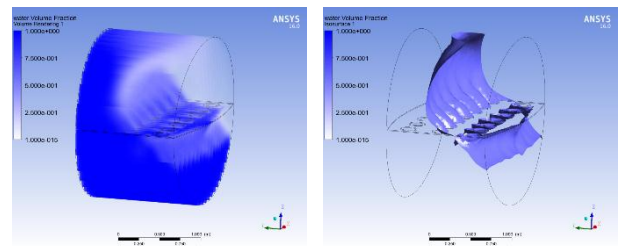

**Fig-10:** Volume fraction & free surface of fluid at 50% fill level in chamber with baffle t=0.32 sec.

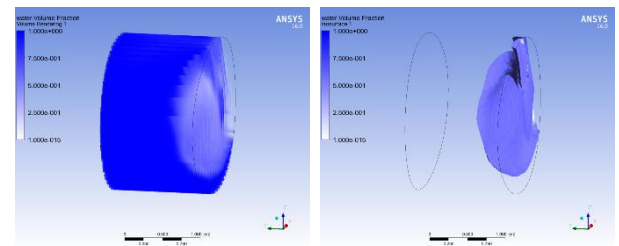

**Fig-11:** Volume fraction & free surface of fluid at 90% fill level in chamber without baffle t=0.48 sec.

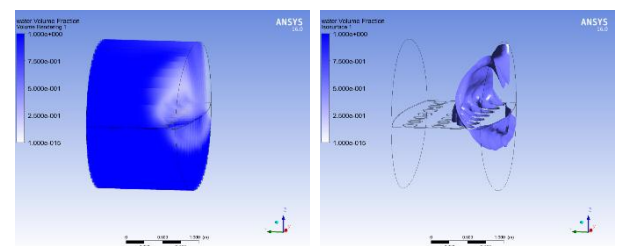

**Fig-12:** Volume fraction & free surface of fluid at 50% fill level in chamber with baffle t=0.48 sec.

Table 2 shows that maximum damping factor of 0.285 at a fill level of 50% was observed for the perforated baffle integrated chamber, however for 30% and 70% fill levels it was 0.167. There was no significant change for 90% fill level.

**Table-2: Fluid oscillation frequency during deceleration**

Fill level (%)	Baffled chamber frequency (HZ)	Un-Baffled chamber frequency (HZ)
30	1.667Hz	2Hz
50	1.667Hz	2.333Hz
70	1.667Hz	2Hz
90	1.667Hz	1.667Hz

### 3.1 Pressure effect

The effect of dynamic pressure causes a surge contributing to rigorous sloshing. Figures 13 to 16 show the pressure profile in both the chambers for respective fill levels at 0.16 seconds. The pressure readings for the baffled chamber were high especially in the initial time period, owing to the fact

that the fluid faces resistance to pass through the baffle holes, as it is constrained to a great extent. Therefore, the pressure rise is more as compared to the chamber without baffles. However, the baffle reduces the pressure surge significantly and its importance is accentuated.

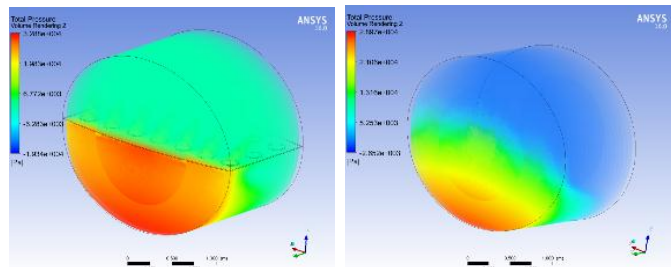

Baffled chamber Un- Baffled chamber

Fig-13: Pressure distribution for 30% fill Level at t=0.16 sec

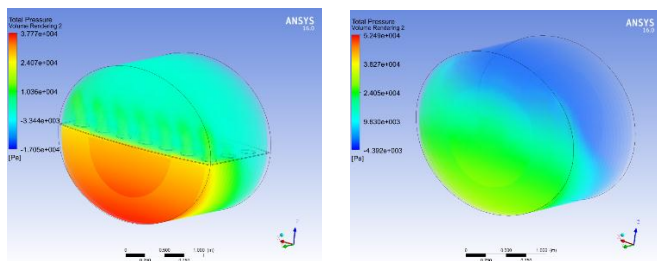

Baffled chamber Un- Baffled chamber

Fig-14 Pressure distribution for 50% fill Level at t=0.16 sec

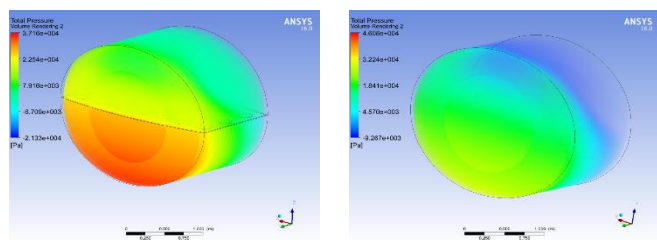

Baffled chamber Un- Baffled chamber

Fig-15: Pressure distribution for 70% fill Level at t=0.16 sec

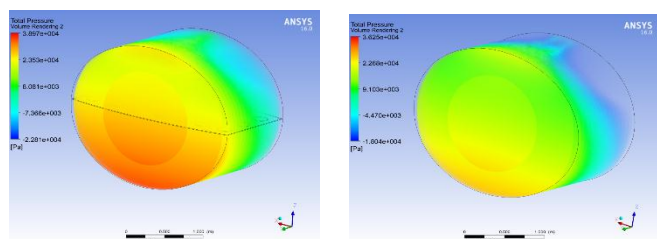

Baffled chamber Un- Baffled chamber

Fig-16: Pressure distribution for 90% fill Level at t=0.16 sec

Charts 1 to 4 show the average fluid pressure trend with respect to time for both chambers at respective fill levels during deceleration. The pressure results show that the pressure reaches a stable value for the baffled chamber quickly as compared to the un-baffled chamber. For fill levels of 50% and 90%, stable pressure value was reached within 1 second whereas for 70% and 30% fill level it required 0.5 seconds and 1.5 seconds respectively. For fill levels of 30% and 50% in the baffled chamber the final stable readings of pressure recorded as 10500 pascal and 12500 pascal respectively were lower than the ones for the chamber without baffle. However, for 70% and 90% fill levels the higher value of stable pressure was observed in the baffled chamber than the un-baffled chamber due to the damping effect.

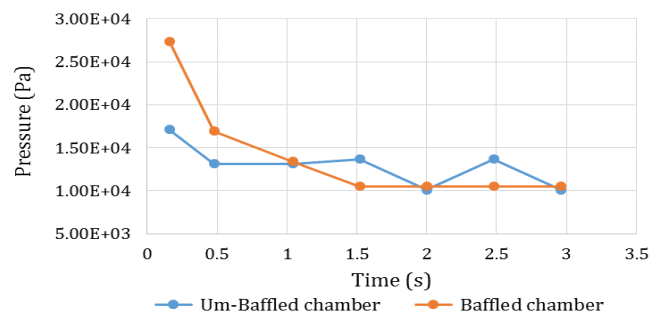

Chart -1: Fluid pressure variation with time for 30% fill level in both chambers.

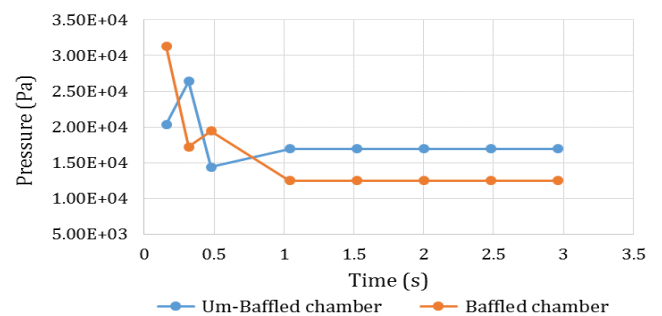

Chart -2: Fluid pressure variation with time for 50% fill level in both chambers.

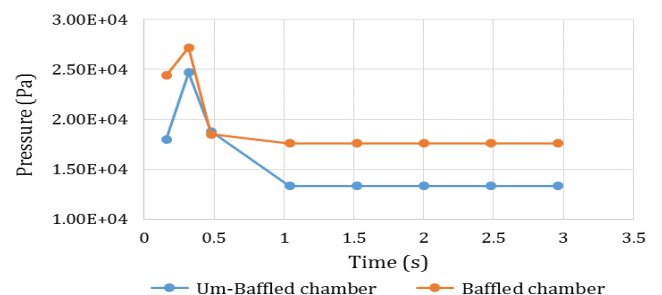
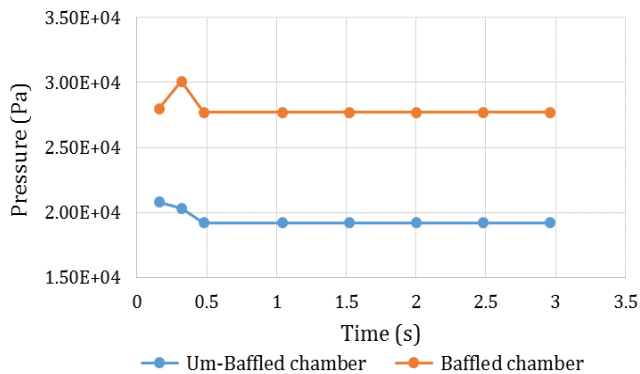
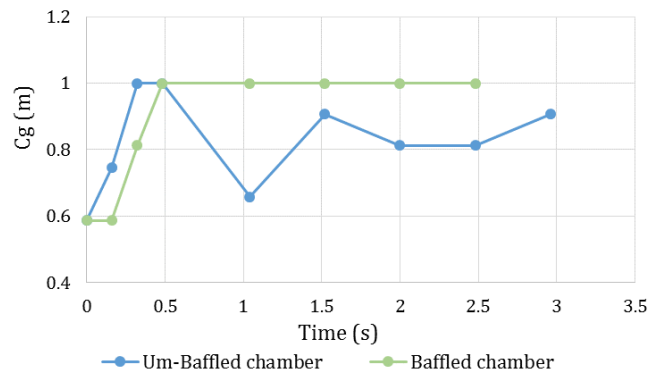

Chart -3: Fluid pressure variation with time for 70% fill level in both chambers.



**Chart -4:** Fluid pressure variation with time for 90% fill level in both chambers.



**Chart -6:** Center of gravity (Cg) variation with time for both chambers at 50% fill level.

### 3. Variation of center of gravity (Cg)

Charts 5 to 8 show the position of instantaneous center of gravity (Cg) from base for both the chambers at respective fill levels, with time under the deceleration period. The time taken for the Cg to stabilize was 0.2 seconds for 90% fill level in both chambers, approximately 0.5 seconds for the rest of fill levels in the baffle incorporated chamber. For 70% fill level Cg stabilized at 2.5 seconds yet for the fill levels below 70% Cg remained unstable throughout the deceleration period for the un-baffled chambers. The continuous rise and fall of Cg affects the traction of the tires with the road. This causes unstable braking and the worst in the case of an evading maneuver, where a sudden rise of Cg while initiating a sharp turn can yield to a larger roll moment, hence contributing to a roll over [8, 3]. Varying Cg contributes to the disruption in the braking of the tank truck as fluid inertia varies frequently while sloshing. Cg for 30%, 50% and 70% fill levels inside the un-baffled chamber fluctuated with a maximum of 0.42 m, 0.315 m and 0.097 m respectively. For 90% fill level Cg was the same with minimal rise of 0.1m for both the chambers simultaneously.

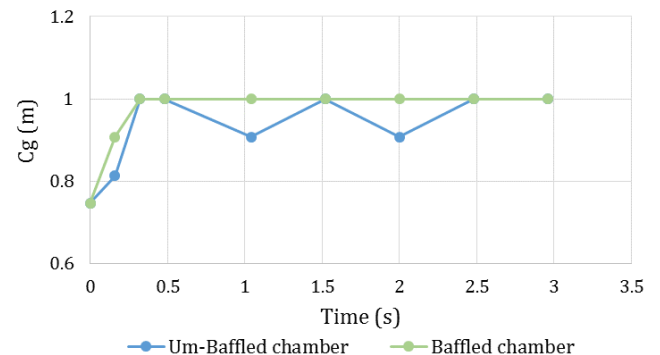

**Chart -7:** Center of gravity (Cg) variation with time for both chambers at 70% fill level.

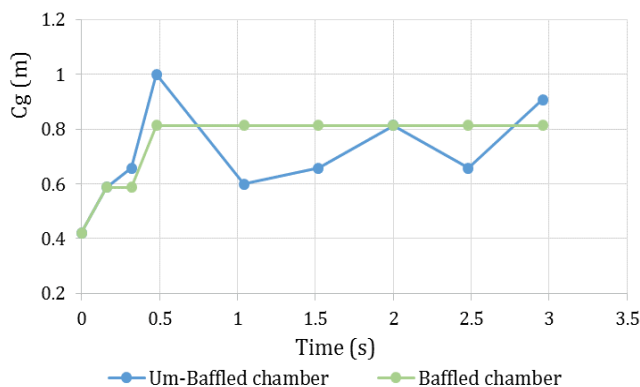

**Chart -5:** Center of gravity (Cg) variation with time for both chambers at 30% fill level.

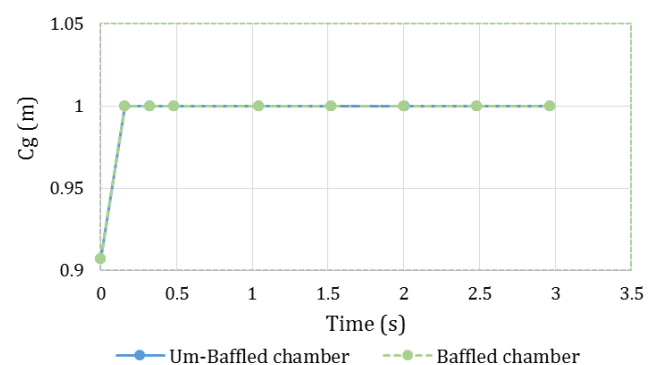

**Chart -8:** Center of gravity (Cg) variation with time for both chambers at 90% fill level.

### 3. CONCLUSIONS

The main conclusion derived from this work is as;

At 50% height the width of the cross section of ellipse is maximum hence the sloshing response was also maximum. Therefore, maximum oscillation frequency was recorded at 50% fill level. In the perforated baffle incorporated chamber a reduction of 28.5% in the oscillation response was

observed. However, at 90% fill level there was no significant difference in the oscillations, therefore the positive effect on damping by the perforated baffle was in the range of 30-70% fill level. The variation in the height of Cg was minimal for the baffled chamber whereas for the chamber without baffle frequent fluctuations in the height of Cg were observed.

The pressure surge in the chamber with perforated baffle was minimal, whereas higher pressure readings were observed due to the resistance offered by the perforated baffle while dampening the surge. For the un-baffled chamber an approximate variation of 11000 Pascal was observed throughout the initial deceleration period for most fill levels. For the baffled chamber such variations were stabilized within a short period of time. As damping is considerably increased with the perforated baffle, the Cg quickly becomes stable therefore the vehicle's linear braking and maneuvering abilities increase, significantly in the initial period of braking, hence through better traction a turn can be initiated to evade an accident with greater stability.

## REFERENCES

- [1] Woodrooffe, "Evaluation of dangerous goods vehicle safety performance," Transport Canada Report, TP 13678 E, 2000.
- [2] Douglas BP, Kate H, Nancy M, et al. Cargo tank roll stability study: final report. Report GS23-0011L, 2007. Washington, DC: US Department of Transportation.
- [3] Modaresi-Tehrani, K., S. Rakheja, and R. Sedaghati. "Analysis of the overturning moment caused by transient liquid slosh inside a partly filled moving tank." Proceedings of the Institution of Mechanical Engineers, Part D: Journal of Automobile Engineering 220, no. 3 (2006): 289-301.
- [4] Bautista-Iacobo, I. L., E. Rodríguez-Morales, I. I. Montes-Rodríguez, and H. Gámez-Cuatzín. "Effect of baffles on the sloshing in road tankers carrying LPG: a comparative numerical study." Mathematical Problems in Engineering 2015 (2015).
- [5] Modaresi-Tehrani, Korang, S. Rakheja, and I. Stiharu. Role of transverse baffle designs on transient three-dimensional liquid slosh in a partly-filled circular tank. No. 2005-01-3594. SAE Technical Paper, 2005.
- [6] Zheng, Xue-lian, Xian-sheng Li, Yuan-vuan Ren, Yu-ning Wang, and lie Ma. "Effects of transverse baffle design on reducing liquid sloshing in partially filled tank vehicles." Mathematical Problems in Engineering 2013 (2013).
- [7] Ali, Saaid, Muhammad Ali Kamran, and Sikandar Khan. "Effect of baffle size and orientation on lateral sloshing of partially filled containers: a numerical study." European Journal of Computational Mechanics 26, no. 5-6 (2017): 584-608.
- [8] Shimanovsky, Alexandr. "Oscillations of partially filled tanker truck at its braking." Engineering for rural development 15 (2016): 1156-1161.
- [9] Yan, G., and S. Rakheja. "Straight-line braking dynamic analysis of a partly filled baffled and unbaffled tank truck." Proceedings of the Institution of Mechanical Engineers, Part D: Journal of Automobile Engineering 223, no. 1 (2009): 11-26.
- [10] Yan, Guorong, Subhash Rakheja, and Kamran Siddiqui. "Experimental study of liquid slosh dynamics in a partially-filled tank." Journal of Fluids Engineering 131, no. 7 (2009): 071303.
- [11] Kolaei, Amir, Subhash Rakheja, and Marc J. Richard. "Effects of tank cross-section on dynamic fluid slosh loads and roll stability of a partly-filled tank truck." European Journal of Mechanics-B/Fluids 46 (2014): 46-58.
- [12] Shimanovsky, A. O., M. G. Kuznyatsova, and Yu M. Pleskachevskii. "The strength analysis of the partitions in road tank reservoirs." Procedia Engineering 48 (2012): 607-612.
- [13] Kolaei, Amir, Subhash Rakheja, and Marc J. Richard. "A coupled multimodal and boundary-element method for analysis of anti-slosh effectiveness of partial baffles in a partly-filled container." Computers & Fluids 107 (2015): 43-58.
- [14] Yu, Di, Xiansheng Li, Hongfei Liu, and Jiahui Dong. "1749. Research on liquid sloshing model of partially-filled tank by nonlinear external excitation." Journal of Vibroengineering 17, no. 6 (2015).

## BIOGRAPHIES



**Umer Abdullah Siddiqui** received his B.E degree in Mechanical Engineering from NED University of Engineering & Technology in 2018. He is an enthusiast of research with interests in Aviation, Marine, Heavy vehicle safety. Currently he is working on patenting his innovation in Tank truck design with low roll over threshold. He presented his research on aircraft tail strike protection devices & won Royal Aeronautical Society Young Person's Lecture Competition Pakistan division in 2018. He came 2<sup>nd</sup> in IET, Present around the World competition in 2018 at Karachi level.



**Bushra Fatima** is a Lecturer at NED University of Engineering and Technology since February 2017. She received her MSc. degree in Sustainable Environment and Energy Systems in 2016 from Middle East Technical University and B.E degree in Mechanical Engineering in 2013 from NED University of Engineering and Technology. Her MSc thesis was based on modelling and simulation of composites based on carbon nanotubes.



**Haseeb Uddin Ahmed Siddiqui** is a Mechanical Engineering Graduate of NEDUET with 6<sup>th</sup> Position in 2018. He worked on Hovercraft manufacturing and its research project.



**Muhammad Hammad**, is a Mechanical Engineering Graduate of NEDUET with 2<sup>nd</sup> Position in 2018. He has been involved in the research work of his final year project based on the prevention of tank trucks roll over.