

# Automatic Traffic Control System Based on the Vehicular Density

K.Priyadharshini<sup>1</sup>, S.K.Manikandan<sup>2</sup>

<sup>1</sup>PG scholar Department of Electrical and Electronics Engineering, Velalar College of Engineering & Technology

<sup>2</sup>S.K.Manikandan Department of Electrical and Electronics Engineering, Velalar College of Engineering & Technology

**Abstract :** The fundamental of this project is to change the timing delay between the traffic light systems automatically according to the number vehicles passing through the lane. In Today's world Traffic congestion is a severe problem in most of the cities. Nowadays fixed time based system is used in traffic signaling system which may provide incompetent if one lane is operational than the others. . It will diminish productivity of the individuals and a lot of work hour is wasted in this system Sometimes higher traffic congestion at one side of the lane needs longer green signal as compared to fixed time based systems, as a result propose here a mechanism in which the time period of green signal and red signal is assigned based on the density of the traffic present at that time. To optimize this problem we have to design an automatic traffic control system. This can be achieved by using PIR (proximity Infrared sensors). Once the density is calculated, the luminous period of green signal is assigned with the help of the microcontroller (Arduino). The sensors which are placed on each sides of the road at a particular distance which will detect the numbers of the vehicle passing that lane and sends the information to the microcontroller based on the information it will decide which lane is to be free or when to revolutionize over the signal lights. In further sections, have to elaborate the procedure of this structure.

**Keywords-IR Sensor, Microcontroller, Traffic light system, LCD**

## I.INTRODUCTION

A huge population is main reason for traffic congestion in India. There is one death every four minutes due to a road accident because of massive population increases use of automobiles and every single one used a separate vehicle to go to exterior it will increase the usage of fuel availability[1-5]. Another fact

of controlling the traffic congestion becomes a major issue because of massive increases of automobiles and larger time delay between the traffic light systems. It reduces the productivity of individual and a lots of work hour is wasted in this systems [8] .In efficient infrastructure, huge numbers of vehicles, Impatient, illogical distribution, Increase of populations are the main reason for traffic congestion. It rapidly increase in pollution level as engines remain on in most of the cases, a massive amount of natural resources in form of petrol and diesel is consumed without any productive outcome[7-11]. So, in order to dispose of these problems, a newer schemes need to be implemented by using sensor based automation technique in this field of traffic signaling system.

In this paper the detailed explanation is given in section 2. The block diagram of proposed system is explained in section 3. The analysis of results is given in section 4.

## II.EXISTING SYSTEM

Traffic congestion is increase in metro city owing to population. For this reason number of automobiles increase rapidly which cause traffic jam in metro city. Under current circumstances, traffic control system is achieved by the use of a hand signs by traffic police persons, traffic light signals, and markings [1-5]. An education program i.e. awareness program is needed through driveling -license authorities, to make sure that those who operate motor vehicles understand the rules and regulation of the road and advised to need of the obeying traffic rules. Figure 2.1 shows heavy traffic congestion



**Fig: 2.1**Traffic Congestion

Every traffic control system is designed by standard signs which make sure when to move or stop. For example, proceed signs always have a green background which is octagonal in shape [12-15]. These Standards are allowed a passengers to move quickly and continuous operation. There are three types of traffic light signs are used for controlling the traffic congestion. It contains standard colors and shape used for identification and deciding on the appropriate course of action. A red lamp indicates the vehicles to stop in the lane at allotted time interval, an amber lamp indicates passengers is ready or start to progress in the lane. A green lamp is used for vehicles to move from the lane. In present situation, traffic lights are set on the different directions with fixed time delay, following a particular cycle while switching from one signal to other.[8-15]



**Fig: 2.2** Normal Traffic Condition

The normal function refers to figure 2.2 traffic lights require slight control and coordinate to ensure that traffic and pedestrians to move forward as safely as possible [17-20]. When heavy traffic condition, the road is crowded with vehicles and go-head time period is short .So vehicles can't move fast as much as it. But sub

lane has few vehicles and go-ahead time interval is relatively long. It is creating unnecessary and wasteful congestion on one lane while the other lanes remain free [16]. In order to rectify this problem, traffic light system has been introduced to change the time delay automatically based on the density of vehicle in a particular lane which is achieved by the use of Sensors [19] .Sensors are placed on each side of the road at a particular distances and interfaced with Microcontroller which sense the traffic system and if may be traffic congestion in one lane it will give the information to the Microcontroller [16-20]. Based on the information from the sensors, microcontroller decides when to open the lane

### III.PROPOSED SYSTEM

This model works on the principle of changing time delay of traffic signals based on the number of vehicles passing through an assigned section of the road. Instead of using fixed time delay traffic light system, here we are placing an Infrared sensor on each side of the road at a particular distance. This sensor range is about 10 meters. It consists of IR transmitter and IR receiver and combined together called as IR transceiver. There are multiple sensors are placed on each sides of the road. These IR transmitter and IR receiver will be mounted on each sides of the all the lanes at a particular distance. As the vehicles pass through these IR sensors, the IR sensor will detect the vehicle and it will send the information to the microcontroller. Based on the information microcontroller will count up the number of vehicles pass through the lane and provide green signal to that lane. It is display on LCD and light glows on Traffic light System.IR Sensor, LCD and Traffic light are interfaced with Microcontroller. The followings are the Block diagram of this Proposed System.

Figure 3.1 is the Block Diagram of proposed system consists of following elements a power supply, Sensor Node, Microcontroller, LCD, Traffic lights. By using these elements proposed system works. The operation of these elements is described below.

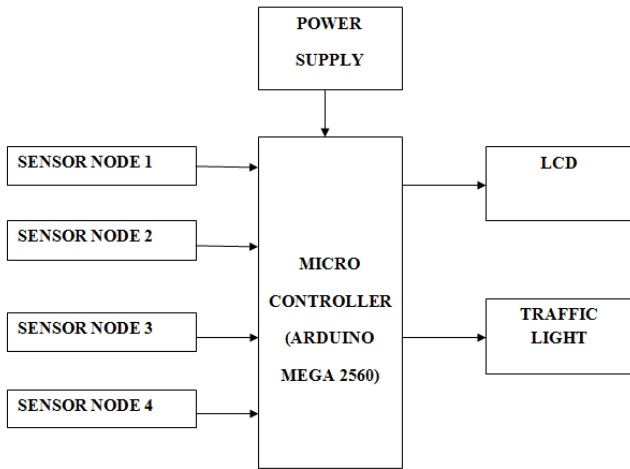

**Fig: 3.1** Block Diagram of Proposed System

Here as per the power requirement of the hardware of the automatic traffic control system, supply of +5V with respect to Ground is used. The entire circuit is operated with TTL logic level of 0-5V. It includes 0V to 9V transformer to step down the 220Volts AC supply to 9Volts AC. In addition a bridge rectifier converts the 9Volts into  $9\sqrt{2}$  DC. It is further filtered through a 1000uF capacitor and then regulated using 7805 to get +5V. To isolate the output voltage of +5V from noise further filter into 220uF capacitor is done. Now it will power to the sensors, traffic light system, microcontroller and LCD. Here IR sensors start to examine number vehicles present in each lane. In the proposed system IR sensors are mentioned by sensor node.

Sensor Node is N numbers of IR sensor placed on all directions that is (North, South, East, and West). An infrared sensor is an electronic device, which senses some of the characteristics around it. An IR sensor can measure the heat of an object and motion of an object. These radiations are invisible to our eyes. It can be detected by an infrared sensor. These Sensors consists of IR transmitter and IR receiver. These will be mounted on each side of the road at a particular distances and sense the number vehicles pass through the lane.

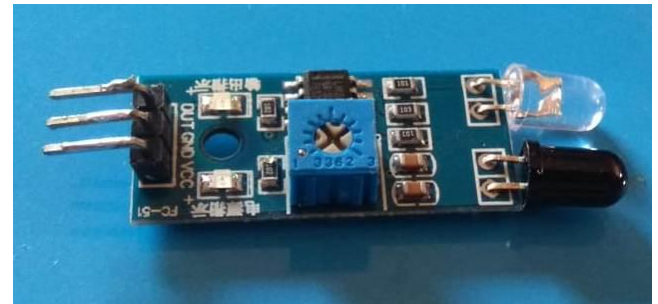

**Fig: 3.2** Infrared Sensors

It gives the information i.e. more number of vehicles present in one lane than the others to microcontroller. The figure 3.2 shows infrared sensor used in the project. IR sensors are interfaced with microcontroller. Arduino Mega 2560 microcontroller is used for controlling the signals. It can be powered through the USB connection or an external power supply. The power source is selected automatically. External (other than USB) power can come either from an AC-to-DC adapter or battery. The adapter can be connected by center-positive plug into the board's power jack. Leads from a battery can be inserted in the Ground and Vin pin headers of the POWER connector.

The board can be operating on an external supply of 6 to 20 volts. If it is supplied with less than 7V, however 5V pin may supply less than five volts and the board may be unsteady. If apply more than 12V, the voltage regulator may overheat and damage the board. The required range is 7 to 12 volts.

Arduino Mega 2560 Microcontroller Board is based on ATmega2560 8-bit microcontroller (MCU). Arduino Mega 2560 has 54 digital input/output pins out of which 15 pins are used as PWM outputs and 16 analog inputs. It includes 4 UARTs (hardware serial ports), a 16MHz crystal oscillator, a USB connection, a power jack, an In-Circuit Serial Programming (ICSP) header, and a reset button.

Mega 2560 includes needs of the user to support the MCU. The user can connect the Mega 2560 to a computer with a USB cable or external power supply. Arduino Mega 2560 board is compatible with most shields designed for the Uno and previous boards Duemilanove or Diecimila. Mega 2560 is an updated version of the earlier Arduino Mega board.

The ATmega2560 has 256 KB of flash memory for storing code out of which 8 KB is used for the boot loader, 8 KB of SRAM and 4 KB of EEPROM which is used to read and written contents in EEPROM library. It provides number of facilities for communicating with computer, another arduino. The Arduino Mega has a resettable polyfuse that protects the computer's USB ports from shorts and over current. Even though most of the computers provide their own internal protection, the fuse provides an extra layer of protection. If apply more than 500 mA to the USB port, the fuse will automatically break the connection until the short or overload is removed.

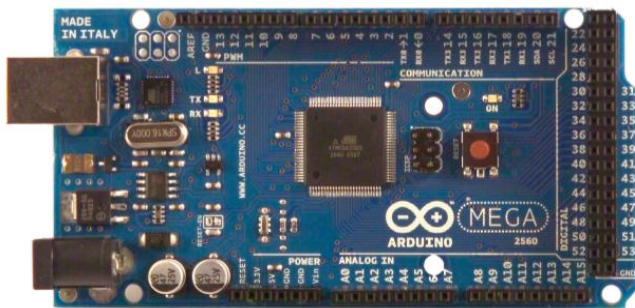

**Fig: 3.3** ArduinoMega2560 MCB

For the above specification reason Arduino mega 2560 is used in these project. Figure 3.3 shows the Arduino mega 2560 Microcontroller Board. This board is placed between sensors and traffic light systems. Now lane 2 has heavy traffic congestion than sublane, so microcontroller provide green signal to lane 2 and red signal to remaining sublane. These will display on LCD.

An LCD is an electronic display module which produces a visible image. The 16x2 LCD display is a basic module commonly used in DIYs and circuits. The 16x2 translates a display of 16 characters per line in 2 such lines. Figure 3.4 refer 16x2 LCD. Some of the examples of LCD using applications are Computers, calculators, television sets, mobile phones, digital watches to display the time and characters.

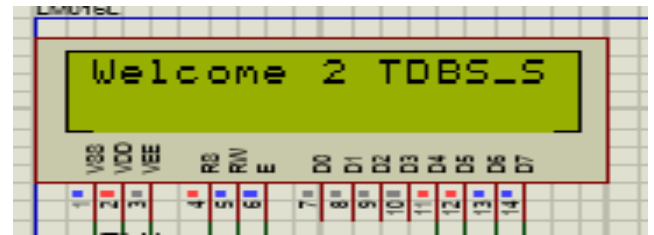

**Fig: 3.4** LCD

And then traffic lights glow according to controller commands. The figure 3.5 shows traffic light signal. These lights are used for alert right way to people by displaying lights of a standard color (red, amber (yellow), and green) following color code. A yellow lamp indicates a warning signal. A red lamp is indicates as a stop sign. A green lamp allows traffic to proceed in the denoted path.

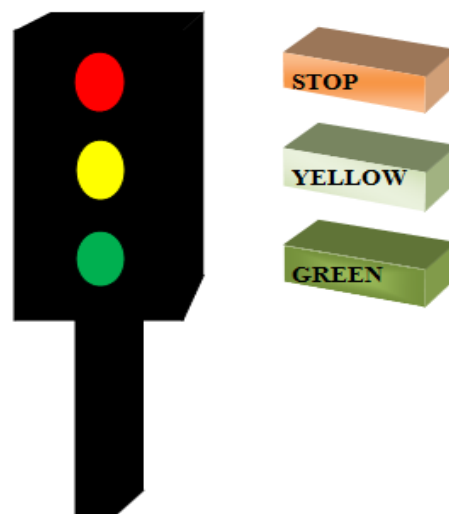
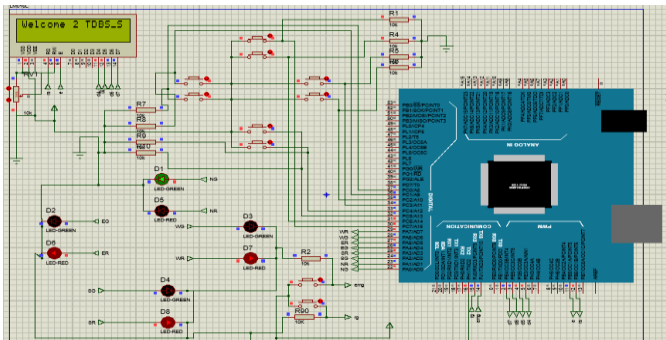

**Fig: 3.5** Traffic light Signal

#### IV.RESULTS

Arduino 1.6.5 and Proteus Design Suite is a software tool used for Simulation. Arduino Mega 2560 library for Proteus files in the libraries folder of Proteus software and code the program in Arduino 1.6.5. It is the simplest and easiest way of coding a program. By using functions and commands of Arduino 1.6.5 IDE to code a program, now run Proteus software and search Arduino Mega 2560. By using this software tool made a Simulation Output for this project.

### 4.1 SIMULATION OUTPUT



**Fig: 4.1.1** Lane 1 Traffic blockage areas

The figure 4.1.1 shows the simulation results of density in Lane1. Now consider heavy traffic congestion in Lane1. IR sensor provide the inform to microcontroller of number of vehicles present in Lane1 afterward it give the green signal to the Lane 1 and give red signal to all the remaining parts.

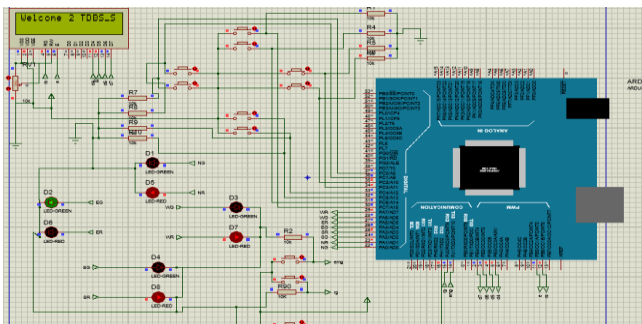

**Fig: 4.1.2** Lane 2 Traffic blockage areas

The figure 4.1.2 shows the simulation results of density in Lane 2. Now consider Lane2 has higher traffic condition, sensor provides inform to microcontroller, it decide which lane contain less number of vehicles in lane 1, lane 3, and lane 4 respectively. After comparisons of other lane provide green signal to lane 2 and remaining lane set to be red.

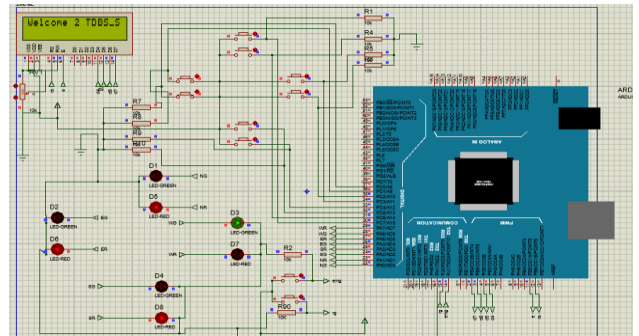

**Fig: 4.1.3** Lane 3 Traffic blockage areas

Based on the information from sensor lane 3 has higher traffic congestion shows in the figure 4.1.3. Microcontroller compares to other lanes and provide green signal to lane 3.

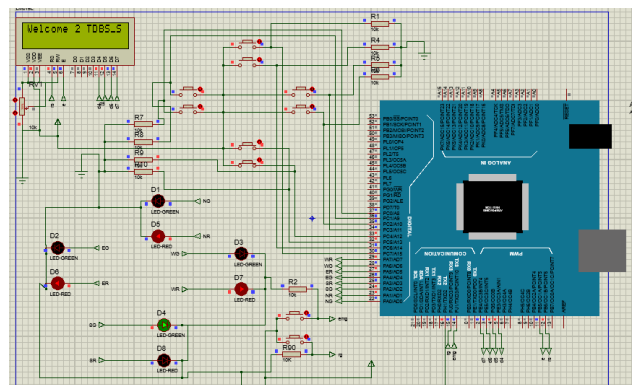

**Fig: 4.1.4** Lane 4 traffic blockage areas

The figure 4.1.4 refers to the simulation density in lane 4. Now consider lane 4 contain heavy congestion, microcontroller compares to other lane and gives the green signal to lane 4 and all others lane set to be red.

### 4.2 HARDWARE SETUP

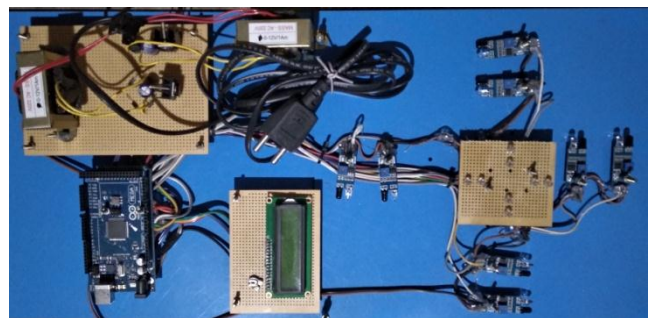

**Fig: 4.2** Hardware setup

The figure 4.2 refers to Hardware setup for this project. Based on the density of the vehicles present in the lanes, infrared sensor give the information to the arduino board it will give the necessary output.

### CONCLUSION

Our country meets with road accidents every day. To reduce this blockages and unwanted time delay in traffic an intelligent control system is designed in this project. This project may be very well used in where the traffic signals is kept and in many other places where to full fill the need of the automation. In the future to implement this project's idea into real life practices. To believes that this may bring a new change in traffic control system.

### REFERENCE

1. Chandramohan, J., Nagarajan, R., Satheeshkumar, K., Ajithkumar, N., Gopinath, P. A., & Ranjithkumar, S. (2017). Intelligent smart home automation and security system using Arduino and Wi-fi. *International Journal of Engineering and Computer Science*, 6(3).
2. Yang, Bo, Rencheng Zheng, Keisuke Shimono, Tsutomu Kaizuka, and Kimihiko Nakano. "Evaluation of the effects of in-vehicle traffic lights on driving performances for unsignalised intersections." *IET Intelligent Transport Systems* 11, no. 2 (2017).
3. M. F. Rachmadi et al., "Adaptive traffic signal control system using camera sensor and embedded system," *TENCON 2011 - 2011 IEEE Region 10 Conference*, Bali, 2011, pp. 1261-1265. doi: 10.1109/TENCON.2011.6129009
4. S. N. Mahalank, K. B. Malagund and R. M. Banakar, "Device to device interaction analysis in IoT based Smart Traffic Management System: An experimental approach," *2016 Symposium on Colossal Data Analysis and Networking (CDAN)*, Indore, 2016, pp. 1-6. doi: 10.1109/CDAN.2016.7570909
5. T. Roopa, A. N. Iyer and S. Rangaswamy, "CroTIS-Crowdsourcing Based Traffic Information System," *2013 IEEE International Congress on Big Data*, Santa Clara, CA, 2013, pp. 271-277. doi: 10.1109/BigData.Congress.2013.43
6. Rajak, B., & Kushwaha, D. S. (2019). Traffic Control and Management Over IoT for Clearance of Emergency Vehicle in Smart Cities. In *Information and Communication Technology for Competitive Strategies* (pp. 121-130). Springer, Singapore.
7. D. Manoj "Density Based Traffic Control System" electrical & electronics engineering Department mahatma Gandhi institute of technology Chaitanya Bharathi P.O., Gandipet, Hyderabad - 500 075 2012
8. B. Prashanth kumar, b. Karthik "micro controller based traffic light controller", Department of Electrical & Electronics Engineering gokaraju rangaraju institute of engineering & technology, 2011
9. Sachin Jaiswal\*, Tushar Agarwal\*, Akanksha Singh\* and Lakshita\* "Intelligent Traffic Control Unit", \*Department of Electronics and Communication Engineering, Bharati Vidyapeeth's College of Engineering, Paschim Vihar, New Delhi-110063
10. Rijurekhasen, Andrew Cross, adityavashista, Venkata N. Padmanabhan, Edward Cutrell, and William Thies "Accurate Speed and Density Measurement for Road Traffic in India" *IIT Bombay*
11. Cihan Karakuzu. "Fuzzy logic based smart traffic light simulator design and hardware implementation". Kocaeli University, Engineering Faculty, Electronics
12. Chandrasekaran, G., Periyasamy, S., & Rajamanickam, K. P. Minimization of test time in system on chip using artificial intelligence-based test scheduling techniques. *Neural Computing and Applications*, 1-10. <https://doi.org/10.1007/s00521-019-04039-6>.
13. Highway traffic model-based density estimation-IEEE paper by Morarescu, Nancy Univ., France, published in *American Control Conference (ACC)*, 2011.
14. Musa Mohd Mokji and Syed Abd. Rahman Syed Abu Bakar, "Directional Image Construction Based on Wavelet Transform for Fingerprint Classification and Matching", *National*

- Conference on Computer Graphics and Multimedia, pp. 331 – 335, 2002.
15. Naik, T., Roopalakshmi, R., Ravi, N. D., Jain, P., & Sowmya, B. H. (2018, April). RFID-Based Smart Traffic Control Framework for Emergency Vehicles. In *2018 Second International Conference on Inventive Communication and Computational Technologies (ICICCT)* (pp. 398-401). IEEE.
  16. Bhate, S. V., Kulkarni, P. V., Lagad, S. D., Shinde, M. D., & Patil, S. (2018, April). IoT based Intelligent Traffic Signal System for Emergency vehicles. In *2018 Second International Conference on Inventive Communication and Computational Technologies (ICICCT)* (pp. 788-793). IEEE.
  17. Zhang, K., Sheng, Y. and Li, J., 2012. Automatic detection of road traffic signs from natural scene images based on pixel vector and central projected shape feature. *IET Intelligent Transport Systems*, 6(3), pp.282-291.
  18. Yapp, J. and Kornecki, A.J., 2015, August. Safety analysis of virtual traffic lights. In *Methods and Models in Automation and Robotics (MMAR), 2015 20th International Conference on* (pp. 505-510). IEEE.
  19. Yang, Bo, Rencheng Zheng, Keisuke Shimono, Tsutomu Kaizuka, and Kimihiko Nakano. "Evaluation of the effects of in-vehicle traffic lights on driving performances for unsignalised intersections." *IET Intelligent Transport Systems* 11, no. 2 (2017)
  20. Higaki, H., 2014, March. Virtual Traffic Signals by Cooperation among Vehicle-Mounted Mobile Computers. In *New Technologies, Mobility and Security (NTMS), 2014 6th International Conference on* (pp. 1-6). IEEE.