

INTERNET OF THINGS BASED EMERGENCY SYSTEM

Allirani A & Mala M

¹Professor: Mrs.R. Jothi, MCA., M.Phil., Associate Professor, Dept. of Computer Science, Dhanalakshmi Srinivasan College Of Arts And Science For Women, Perambalur, Tamil Nadu, India.

Abstract - Internet Of Things (IoT) a shared network of objects or things which can interact with each other provided the Internet connection. IoT plays an important role in agriculture industry which can feed 9.6 billion people on the Earth by 2050. The proposed system does require a IOT module with respect to communicate with user and offers a control environment using cloud computing. To demonstrate the feasibility and effectiveness of this system, We are using the sensor to sense the accident, and then the signal is feed to the microcontroller. The information will be automatically transmitted with suitable alertness through IOT module with GPS location. This project is useful in detecting the accident precisely by means of accident(vibration) sensor. The accident information system will alert vehicle owner relative or nearby hospital through IoT with the accident location using GPS. If the accident is a minor one then driver can press the reset switch and drive normally. As a future implementation a wireless webcam can be added for capturing the images of the accident scene.

Key Words: IOT, Arduino, GPS

1. INTRODUCTION

In the modern world of science and technology, Transportation system is as important as breathing air. Due to this we are having a sense of having the highest civilization of the planet. Automobiles play a vital role in our daily life but as it is said, with some good aspects there comes bad one too. Road accidents are a major threat to human lives. Speed is the key factor responsible for many of the accidents. The statistics which have been formed according to the recent surveys are really horrific. According to a survey conducted in 2013 by Hindustan Times in India in every three minutes there is one death due to the road accidents in which 77% of accidents are due to manual mistakes. According to a recent survey by WHO published in Times of India, India is on 1st position globally in terms of casualties occurred due to road accidents. Despite of many safety measures and programs launched by the governmental as well as nongovernmental organizations to make people aware of safe driving concept, life claimed by these accidents

are increasing at an alarming rate. In a study it has been found that fifty percent's of casualties occurred due to road accidents could have been stopped if they got immediate medical help. As in most of the cases the accidents results into casualties not because of the seriousness of the accident but due to the lack of immediate medical attention, delay in getting the medical help is one the major reasons for the casualties. Hence it is the essential need of the present scenario to develop some technologies so that tracking of the accident cases becomes easier which in turn will further lower down the death rate.

The Internet of Things (IoT) is the interconnection of uniquely identifiable embedded computing devices within the existing Internet infrastructure. Typically, IoT offers advanced connectivity of devices, systems, and services that goes beyond machine-to-machine communications (M2M) and covers a variety of protocols, domains, and applications. The interconnection of these embedded devices (including smart objects), is implemented in nearly all fields of automation enabling advanced applications like a Smart Grid. The term things in the IoT refers to a wide variety of devices such as heart monitoring implants, biochip transponders on farm animals, electric clams in coastal waters, automobiles with built-in sensors, or field operation devices that assist fire-fighters in search and rescue. Current market examples include thermostat systems and washer/dryers that utilize Wi-Fi for remote monitoring system

GPS DEVICE

The Global Positioning System (GPS) is a space based global navigation satellite system (GNSS) that provides reliable location and time formation in all weather and times anywhere on the globe. The GPS satellites act as are reference point from which receivers on the ground detect their position. The fundamental navigation principle is based on the measurement of pseudo ranges between the user and four satellites

Arduino

Arduino is open-source hardware. The hardware reference designs are distributed under a Creative

Commons Attribution Share-Alike 2.5 license and are available on the Arduino website. Layout and production files for some versions of the hardware are also available. The source code for the IDE is released under the GNU General Public License, version 2.^[8] Nevertheless, an official Bill of Materials of Arduino boards has never been released by Arduino staff.

Arduino board designs use a variety of microprocessors and controllers. The boards are equipped with sets of digital and analog input/output (I/O) pins that may be interfaced to various expansion boards (shields) and other circuits. The boards feature serial communications interfaces, including Universal Serial Bus (USB) on some models, which are also used for loading programs from personal computers. The microcontrollers are typically programmed using a dialect of features from the programming languages C and C++. In addition to using traditional compiler tool chains, the Arduino project provides an integrated development environment (IDE) based on the Processing language project.

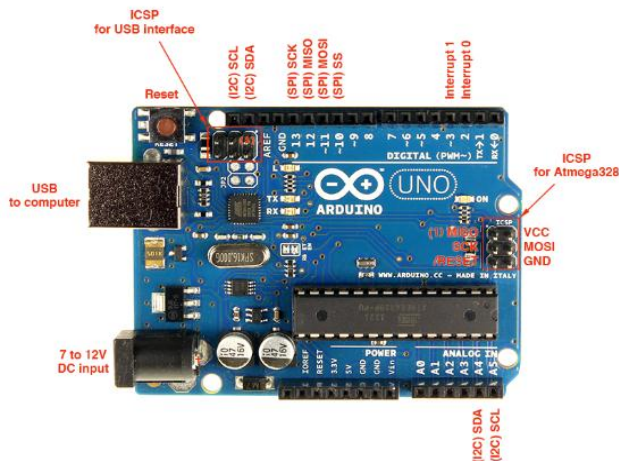

BLOCK DIAGRAM

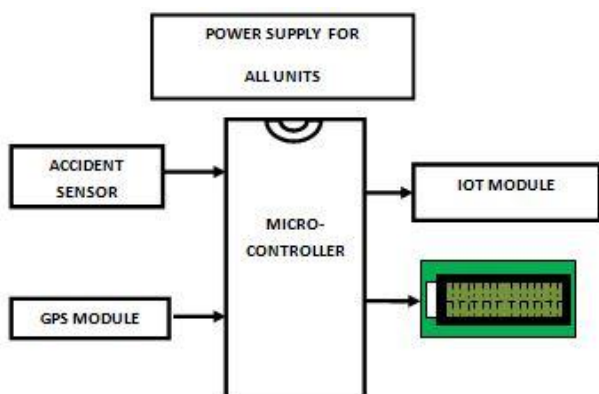

4. Conclusion

This project presents the automatic vehicle accident identification and alerting system using IOT. This design is the system which can detect the accidents in less time and sends the information to the first aid center through cloud. This project is user-friendly and reliable. The proposed method is highly beneficial to the automotive industry. In this system, data logging and analysis can be implemented to monitor the accident situations in various regions.

REFERENCES

[1]Design of vehicle positioning system based on arm-- IEEE- 2011. Zhang Wen; Dept. of Phys. & Electron. Inf. Eng., Neijiang Teachers Coll., Neijiang, China ; Jiang Meng may 2011.

[2]Intelligent anti-theft and tracking system for automobiles----IEEE-2012 February 2012 Montaser N. Ramadan, Mohammad A. Al-Khedher, Senior Member,IACSIT, and Sharaf A. Al- Kheder.

[3]Zhu Yi, Yang Shubo. MMA series of acceleration sensor principles and application. Medical equipment, 2008.

[4]Fleischer, P.B.; Nelson, A.Y.; Sowah, R.A.; Bremang, A., "Design and development of GPS/GSM based vehicle tracking and alert system for commercial inter-city buses," Adaptive Science & Technology (ICAST), 2012 IEEE 4th International Conference on , vol., no., pp.1,6, 25-27 Oct. 2012.

[5]Iman M. Almomani, Nour Y. Alkhalil, Enas M. Ahmad, Rania M. Jodeh "Ubiquitous GPS Vehicle Tracking and Management System", IEEE Jordan Conference on Applied Electrical Engineering and Computing Technologies (AEECT) 2011.

[6]Iman M. Almomani, Nour Y. Alkhalil, Enas M. Ahmad, Rania M. Jodeh "Ubiquitous GPS Vehicle Tracking and Management System", IEEE Jordan Conference on Applied Electrical Engineering and Computing Technologies (AEECT) 2011.

[7]Le-Tien, T.; Vu Phung-The, "Routing and Tracking System for Mobile Vehicles in Large Area," Electronic Design, Test and Application, 2010. DELTA '10. Fifth IEEE International Symposium on , vol., no., pp.297,300, 13-15 Jan. 2010.

[8]. Adnan I. Yaqzan, Issam W. Damaj, and Rached N. Zantout(July 24, 2008), ' GPSBased Vehicle Tracking System-On-Chip', Proceedings of the world Congress on Engineering Vol I WCE.

[9]Ziad A. Osman, MazenJrab, SouleimanMidani, Rached N. Zantout (May 2003), 'Implementation of a System for Offline Tracking using GPS',Mediterranean Microwave Symposium, Ain Shams University, Cairo,Egypt, pp. 203-207

BIBLIOGRAPHY

	<p>Mrs. Jothi.R – Received MCA.,M.Phil., Degree In Computer Science. She Has 13 Years Of Teaching Experience. She Had Presented 5 Papers In International Conference And Also She Presented 4 Papers In National Conference. She Is Currently Working As Associate Professor In Department Of Computer Applications In Dhanalakshmi Srinivasan College Of Arts And Science For Women , Perambalur, Tamil Nadu, India.</p>
	<p>Ms. M. Mala , PG scholar, Department of Computer Science, Pursuing MCA in Dhanalakshmi Srinivasan College Of Arts And Science For Women , Perambalur-621 212, Tamil Nadu, India.</p>
	<p>Ms. A. Allirani , PG scholar, Department of Computer Science, Pursuing MCA in Dhanalakshmi Srinivasan College Of Arts And Science For Women, Perambalur-621 212, Tamil Nadu, India.</p>