

Analysis of T-Beam Bridge with Mild Steel Strip in Various Positions

Lekshmi Unnikrishnan¹, Abhirami Suresh²

¹Mtech Student, Sree Narayana Institute of Technology, Adoor, Kerala

²Assistant Professor, Sree Narayana Institute of Technology, Adoor, Kerala

Abstract - T-beam bridge is one of the principal types of cast-in place concrete bridge. Under service loading T-beam bridges show excessive deflection, cracking and inadequate ultimate strength. For improving the performance of bridge, mild steel strips are used as a composite material. Mild steel strips increase the stiffness of the member, reduce deflection of the structure and act as shear reinforcement. They are economic, durable and are available in varying thickness. This research presents the study of feasibility and efficiency of T- beam bridge with Mild steel strip as a composite material to control deflection. For analysis mild steel strip are placed in various position in the web portion of the T-beam. The modeling and analysis are done using ANSYS R18.1.

Key Words: T-beam, Mild Steel Strip, Deflection, Stiffness, ANSYS.

1. INTRODUCTION

Bridge is a structure providing passageway over an obstacle without closing the way beneath. Reinforced Concrete is usually used for highway bridge construction because of its durability, rigidity, economy and ease of construction.

T-beam, used in construction, is a load-bearing structure of reinforced concrete, wood or metal, with a T-shaped cross section. The top of the T-shaped cross section serves as a flange or compression member in resisting compressive stresses. The web of the beam below the compression flange serves to resist shear stress and to provide greater separation for the coupled forces of bending.

T-beam bridge consists of a concrete slab monolithically cast over longitudinal girders. The number of longitudinal girders depends on the width of the road. Three girders are normally provided for a two-lane road bridge. T- beam bridges are composed of deck slab 20 to 25cm thick and longitudinal girders spaced from 1.9 to 2.5m.

An important and economic combination of construction materials is that of steel and concrete. The concept of composite construction has been adopted in this project to regulate deflection and to check failure due to serviceability

Here Mild steel strips are used as a composite material to modify the performance of bridge under service loading. The composite action of steel and concrete provides resistance to imposing load and more importantly improves the stiffness of the member. It has many benefits over ancient reinforced concrete or steel structures; these include high strength to weight ratio, structural integrity, dimensional stability etc.

1.1 Objective

1. To explore the innovative construction technology where steel strip acts compositely with surrounded concrete
2. To analyze the bridge with MS steel strips by placing in different positions.
3. Increase the stiffness of member by controlling deflection
4. To compare the performance of bridge with and without MS strips in terms of deflection.

2. SOFTWARE USED

Modeling and analysis were done using ANSYS R18.1. ANSYS was selected since the software is capable of solving complex structural engineering problems and make better, faster design decisions.

3. MODELLING OF BRIDGE

3.1 Bridge Description

- Span of bridge :16m.
- Clear width of roadway :7.5m
- Thickness of slab :0.2m
- Wearing coat thickness :0.08m
- Concrete mix : M25
- Steel : Fe415 (HYSD)
- Width of longitudinal girder : 0.3m.

Three main girders are provided at 2.5m spacing and IRC Class AA tracked vehicle was considered for live load calculation.

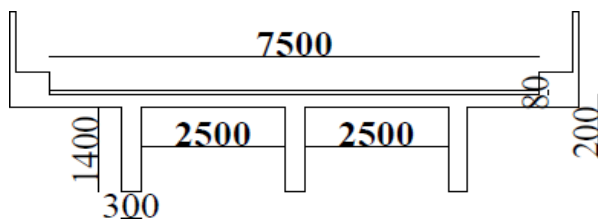

Fig -1: Dimension of bridge

The modelling was done using ANSYS R18.1. Three models of bridge were created.

1. Model of conventional bridge
2. Model of bridge with 3.15mm mild steel strip
 - a) Full depth of web throughout the length.
 - b) Top and bottom of the web, throughout the length.

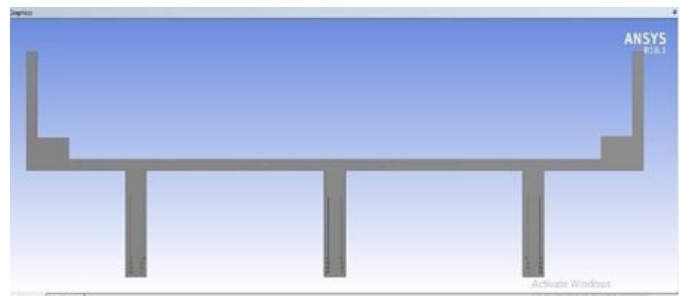

Fig -5: Cross section of bridge with 3.15mm mild steel strip (Full depth of web)

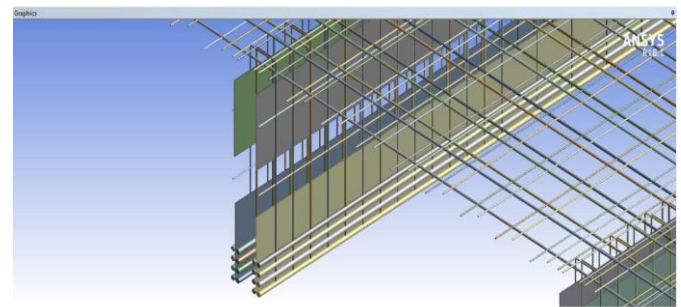

Fig -6: Position of mild steel strip(3.15mm) (Top and bottom of web)

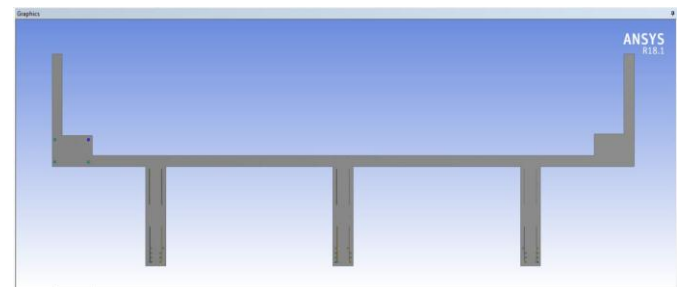

Fig -7: Cross section of bridge with 3.15mm mild steel strip (Top and bottom of web)

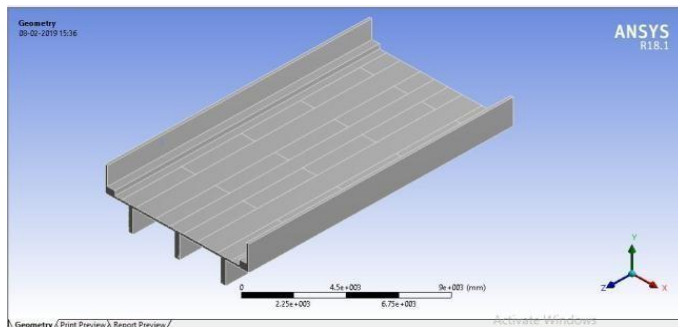

Fig -2: Model of conventional bridge

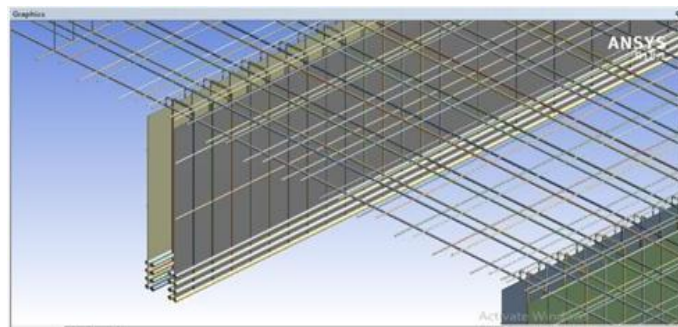

Fig -3: Position of mild steel strip (3.15mm) (Full depth of web)

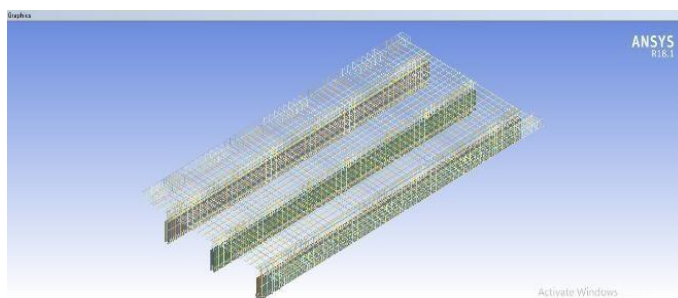

Fig -4: Layout of bridge with mild steel strip (3.15mm) (Full depth of web)

4. LOADS ON BRIDGE

Various types of loads are considered for design of bridge structures. These loads and their combinations decide the safety of the bridge construction during its use under all circumstances. The design loads should be considered properly for perfect design of bridge. Different design loads acting on bridges are explained below.

1. Dead load
2. Live load
3. Impact load
4. Wind load
5. Longitudinal forces
6. Centrifugal forces
7. Buoyancy effect
8. Effect of water current
9. Thermal effects
10. Deformation and horizontal effects
11. Erection stresses

12. Seismic Loads

IRC recommended some imaginary vehicles as live loads which will give safe results against the any type of vehicle moving on the bridge. The vehicle loadings are categorized in to three types and they are

1. IRC class AA loading
2. IRC class A loading
3. IRC class B loading

Here, IRC Class AA tracked vehicle loading is adopted as live load

4.1 IRC Class AA Loading

This type of loading is considered for the design of new bridge especially heavy loading bridges like bridges on highways, in cities, industrial areas etc. In class AA loading generally two types of vehicles considered, and they are tracked type and wheel type.

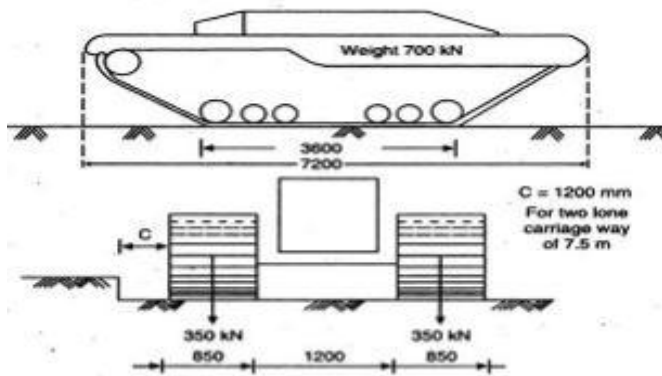

Fig -8: IRC Class AA tracked vehicle

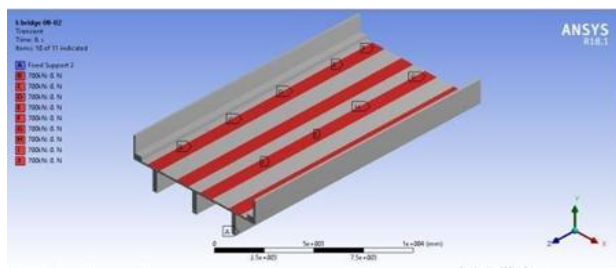

Fig -9: Loading diagram of conventional bridge

5. ANALYSIS

5.1 Transient Analysis

Transient dynamic analysis is a technique used to determine the dynamic response of a structure under the action of any general time-dependent loads. We can use this analysis to determine the time varying displacements, strains, stresses and forces in a structure as it responds to any combination of static, transient and harmonic loads.

The analysis of bridge with and without mild steel strip was done using ANSYS R18.1 to find out the total deformation

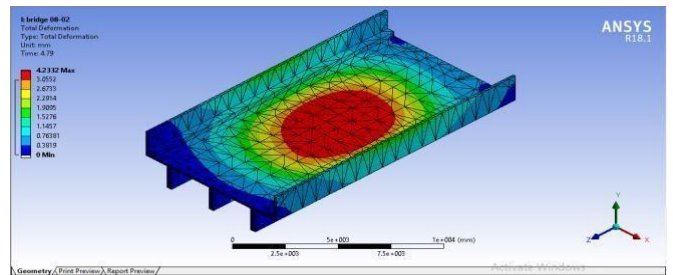

Fig -10: Total deformation diagram of conventional bridge

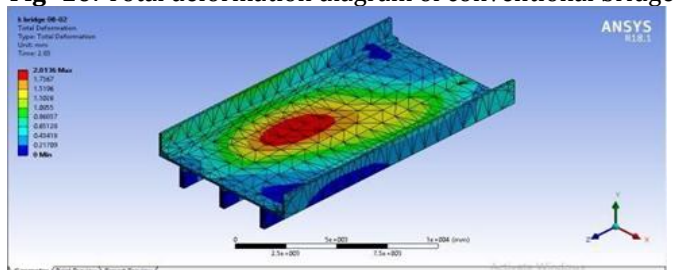

Fig -11: Total deformation diagram of bridge with 3.15mm mild steel strip (Full depth of web)

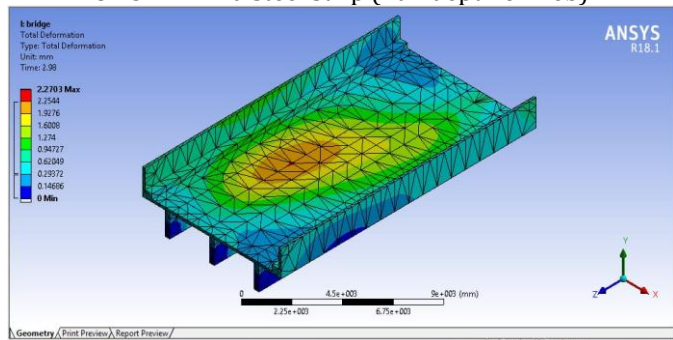

Fig -12: Total deformation diagram of bridge with 3.15mm mild steel strip (Top and bottom of web)

6. RESULTS AND DISCUSSIONS

From the analysis done different parameters like deflection and stiffness were taken into consideration to check the feasibility of the project.

Table -1: Deformation obtained from analysis

SL NO	Position of Strip	Deformation
1	Without the strip (Conventional)	4.2332
2	Full depth of web	2.0136
3	Top and bottom of web	2.1191

7. CONCLUSION

Providing mild steel strips has proved to reduce the deflection in bridges considerably. Also 3.15 mm thick steel strip is found to be more effective on comparing with other available thickness of strips. Analysis was done using ANSYS R18.1 on bridges by varying the position of mild steel strip.

For the analysis two positions were considered which include placing the strip in full depth of the web and top and bottom of the web. The results were comparable. Hence providing mild steel strips in full depth is advisable considering economy and ease of installation.

ACKNOWLEDGEMENT

The Author(s) wish to express their special gratitude to Dr. P. G. Bhaskaran Nair, PG Dean, Sree Narayana Institute of Technology, Adoor, Above all the author(s) thank GOD Almighty for His grace throughout the work.

REFERENCES

- [1] Abisheik A, Dr R Sathyanarayan Sridar " Non Linear Static Analysis Of T-Beam Bridge", IJET, Vol 4, Issue 05, 2017.
- [2] Alpesh Jain, Dr J .N Vyas "Modal Analysis Of Bridge Structures Using Finite Element Analysis", IOSR, Vol 13, Issue 04, 2016.
- [3] Asif Reyaz, Mohamad Mohsin Thakur, Ali, Ishtiyak Ahmad "Deflection Control In RCC Beams By Using Mild Steel Strips (An Experimental Investigation)", IJRET, Volume: 03 Issue: 09, 2014.
- [4] R. Shreedhar, Spurti Mamadapur "Analysis of T-beam Bridge Using Finite Element Method", IJEIT, Vol:2, Issue:3, 2012.
- [5] David A.M. Jawad and Anis A.K. Mohamad-Ali " Analysis Of The Dynamic Behaviour Of T-beam Bridge Decks Due To Heavyweight Vehicles", Emirates Journal for Engineering Research, 15 (2), 2010.