

# IoT Based Real Time Greenhouse monitoring system using Raspberry Pi

Miss. Aishwarya Kore<sup>1</sup>, Dr. Deepak Kadam<sup>2</sup>

<sup>1</sup>Dept of Electronics and Telecommunication Engineering

<sup>2</sup>Associate Professor, Dept of Electronics and Telecommunication Engineering

<sup>1,2</sup>PVPIT, Budhgaon, Sangli, Maharashtra, India

**Abstract:** Raspberry pi is useful for small application developmen. This proposed work is a stepping stone to introduce the various features and possibilities available in the raspberry pi and opens up an avenue for researches who wish to embark into these new inventions. Raspberry pi can also be used as an educational tool as it comes with scratch as an animation tool for young learners. The system gives real time remote monitoring system using Raspberry Pi which enables the user to track the different parameters in green house remotely for improving plant growth. The data storage in the database on the cloud for future use in any internet enabled device. This facilitates us to take right decisions at right time to obtain desired results in plant growth.

**Index Terms** - Green house, Raspberry-pi, IOT, sensors.

## 1. INTRODUCTION

Greenhouses are frames of inflated structure covered with a transparent material in which crops are grown under controlled environment conditions such as surrounding temperature, humidity, nutrient, soil moisture, etc. The environment inside the greenhouse will affect the quality of the plants. As a result, it is important to maintain the parameter such as temperature, light, humidity, and soil moisture. Climate control requires real-time precise measurement. A Raspberry Pi is a credit card-sized computer. It is small size and accessible price. The Raspberry Pi is slower than a modern laptop or desktop but is still a complete Linux computer and can provide all the expected abilities that implies, at a low-power consumption level. One advantage of using the Raspberry Pi over some other alternatives is the size of the community. Other peripherals can be attached through the various pins and connectors on the surface of the Raspberry Pi. Wireless sensor network technology has been emerging as a feasible solution to many innovate applications. WSN is a low cost wireless network made up of thousands of small sensor nodes which monitor physical or environmental conditions, such as temperature, humidity, soil moisture,

turbidity, etc at different locations. The sensor nodes can transmit the data detected by their own sensor and can also pass the data to adjacent nodes. The data can be detected by the sensor nodes and can be transmitted to the base station. After that the data is transmitted to the end user by external network. It can also send command of end user to the network node.

The Internet of Things is a vision of a world in which most objects are connected, transmitting updates about their performance so the people who use them to do the things more intelligently. This vision is being built today, with connected devices becoming more and more frequent in our daily lives. The basic concept behind the internet of things is that virtually every physical thing in this world can also become a computer that is connected to internet.

## 2. LITERATURE REVIEW

Ravi Kishore Kodali, Vishal Jain and Sumit Karagwal[1] developed a monitoring and control system for greenhouse through Internet of Things (IOT). The system will monitor the various environmental conditions such as humidity, soil moisture, temperature, presence of fire, etc. This work is primarily about the improvement of current agricultural practices by using modern technologies for better yield. This work provides a model of a smart greenhouse, which helps the farmers to carry out the work in a farm automatically without the use of much manual inspection. Sheetal Vatari; Aarti Bakshi; Tanvi Thakur, suggested Green house by using IOT and cloud computing[2]. There are many techniques available for the precision agriculture to monitor and control, environment for the growth of many crops. Green House is the best solution to control and manage all this problems. It is more important to search a method that gives perfect analyzation and controlling to develop proper environment. This environment builds up by using two technologies IoT and cloud computing. By using IOT we control devices or any environmental needs anytime, anywhere and the cloud which provides storage and computing resources to implement a webpage. Akshay D. Deshmukh; Ulhas B. Shinde[3]

presented the proceeding of a low cost environment monitoring system using raspberry Pi and arduino with Zigbee discuss a monitoring system which gives information about environmental conditions on a more local level and bringing out the new scope in monitoring the current environment problems. S. G. Nikhade[4] proposed Wireless sensor network system using Raspberry Pi and zigbee for environmental monitoring applications, a wireless sensor network system that we have developed using open-source hardware platforms, Raspberry Pi and zigbee. Mohannad Ibrahim; Abdelgha for Elgamri; Sharief Babiker[5] proposed the paper on Internet of things based smart environmental monitoring using the Raspberry-Pi computer , Ahmed Mohamed an approach to build a cost effective standardized environmental monitoring device using the Raspberry-Pi (R-Pi) single-board computer. The system was designed using Python Programming language and can be controlled and accessed remotely through an Internet of Things platform. Nagaraj Patil, Anand K Warad[6] presented a paper IOT and Raspberry Pi based environmental Monitoring application. The wireless sensor network system and Internet of things (IOT), by using WSN it develops an open source hardware platform, raspberry pi (2B model), zigbee and sensors. It is low cost, low power consuming device and highly scalable in a type of sensors and the number of sensor nodes. It is low cost, low power consuming device and highly scalable in a type of sensors and the number of sensor nodes.

### 3.PROPOSED SYSTEM

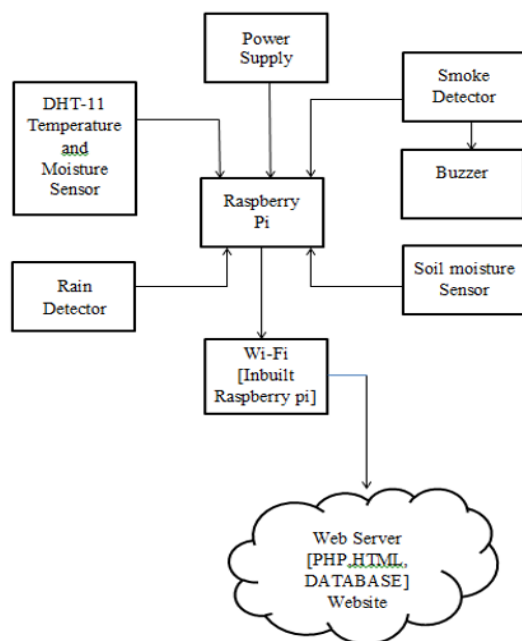

Figure 1. block diagram of proposed work

The basic block diagram of proposed work is presented in figure 1. The system is designed based on the following features: all nodes are similar in architecture and functionality, architecture can be improved in simple way; low power consumption, power effective, every node is capable of transmitting the data collected to the central system directly of working cooperatively with the rest one. We have developed the sensor nodes network using raspberry pi and IoT. Raspberry pi acts as a main processor. A wireless sensor network consists of raspberry pi as a master as well as different types of sensors. A regulated power supply is provided to the overall system. The wireless sensor technology comprises of raspberry pi, wireless sensor network (WSN) and sensors. The system is developed using open source hardware raspberry pi which proves to be cost effective and having low power consumption. The sensors will gather the data of various environmental parameters and provide it to raspberry pi which act as a base station. The raspberry pi will then transmit the data using IoT and the processed data will be displayed on IoT.

#### 3.1 Sensor Unit

The sensors are deployed in the greenhouse which senses the current climatic values of greenhouse. The overall system is controlled by microcontroller of raspberry Pi. Different types of sensors are attached to the sensor nodes. There is serial communication between sensor unit and raspberry Pi. Five types of sensors are attached to it i.e temperature, humidity, soil moisture, rain detector and smoke detector. Also a buzzer is attached to smoke detector sensor.

The humidity and temperature sensor DHT 11 is used here. Humidity sensor will measure the water content in the atmosphere. The rated voltage is DC 5.0 V. and its operating temperature is 0-600C. The temperature sensor is modulated on DHT 11. It will measure both temperature as well as humidity. The soil moisture sensor can be used to test the moisture of soil, when the soil is having water shortage, the module output is at high level, or else the output is at low level. The rain sensor module is an easy tool for rain detection. It can be used as a switch when raindrop falls through the raining board and also for measuring rainfall intensity. The module features, a rain board and the control board that is separate for more convenience, it as an adjustable sensitivity though a potentiometer. The analog output is used in detection of drops in the amount of rainfall. Connected to 5V power supply, the LED will turn on when induction board has no rain drop, and DO output is high. When dropping a little amount water, DO output is low, the switch indicator will turn on. Brush off the water droplets, and when restored to the initial state, outputs high level. Smoke

detector MQ sensor it detect a gas is very easy. You can either use the digital pin or the analog pin to accomplish this. Simply power the module with 5V and you should notice the power LED on the module to glow and when no gas it detected the output LED will remain turned off meaning the digital output pin will be 0V. Introduce the sensor to the gas you want to detect and you should see the output LED to go high along with the digital pin, if not use the potentiometer until the output gets high. Now every time your sensor gets introduced to this gas at this particular concentration the digital pin will go high (5V) else will remain low (0V). As soon as smoke or gas is detected the buzzer beeps i.e. it produces sound. It is in the range of 2 kHz to 4 kHz. IoT is used for transferring of data of devices via internet. By using IoT we can control the appliances anywhere and anytime by just using the SSH remote login or by putty software just by adding Raspberry Pi IP address in it. The cloud provides storage and computing resources to implement webs application. The data is stored on the web server.

### 3.2 Web Server

We have developed the website of green house. On this website we will get the all information about the devices placed in the green house. But this website is accessible only those having login ID and password. A Web server is a program that uses HTTP (Hypertext Transfer Protocol) to serve the files that form Web pages to users, in response to their requests, which are forwarded by their computers' HTTP clients.

## 4. COMPONENT DETAILS

### 4.1 Raspberry pi

The raspberry pi is a low cost, low power credit size single board computer which has recently become very popular. The raspberry pi is the cheapest ARM11 powered Linux operating system capable single board computer board. It has many operating systems. Raspberry Pi can be connected to a local area network through Ethernet cable or USB Wi-Fi adapter, and then it can be accessed by more than one client from anywhere in the world through SSH remote login or by putty software by just putting raspberry pi ip address in it. The raspberry pi is booted by external SD or micro SD card.

### 4.2 DHT 11 humidity and temperature sensor

They consist of a humidity sensing component, a NTC temperature sensor (or thermistor) and an IC on the back side of the sensor. For measuring humidity they use the humidity sensing component which has two

electrodes with moisture holding substrate between them. So as the humidity changes, the conductivity of the substrate changes or the resistance between these electrode changes.. On the other hand for measuring temperature these sensors use a NTC temperature sensor or a thermistor. A thermistor is actually a variable resistor that changes its resistance with change of temperature.

### 4.3 Soil Moisture sensor

This sensor can be used to test the moisture of soil, when the soil is having water shortage, the module output is at high level, and else the output is at low level. By using this sensor one can automatically water the flower plant, or any other plants requiring automatic watering technique. Module triple output mode, digital output is simple, analog output more accurate, serial output with exact readings.

### 4.4 Rain detector sensor

It is a simple sensor and it is an easy to use tool for detecting rain. It can act as a simple switch, where the switch is normally open and when there is rain, the switch closes.

### 4.5 Smoke detector

MQ sensor it detect a gas is very easy. You can either use the digital pin or the analog pin to accomplish this. Simply power the module with 5V and you should notice the power LED on the module to glow and when no gas it detected the output LED will remain turned off meaning the digital output pin will be 0V. When you introduce the sensor to the gas you want to detect and you will see the output LED to go high along with the digital pin, if not use the potentiometer until the output gets high. Now every time your sensor gets introduced to this gas at this particular concentration the digital pin will go high (5V) else will remain low (0V).

### 4.6 Buzzer

A piezo buzzer is a sound producing device. The main working principle is based on the theory that, whenever an electric potential is applied across a piezoelectric material, a pressure variation is generated. Piezo buzzers generate a loud & sharp sound. So, they are typically used as a alarm circuits. Also they are used to make an alert of an event, signal or sensor input.

### 5. HARDWARE IMPLEMENTATION

The main component of the hardware is Raspberry Pi. The sensors used are temperature sensor, humidity sensor, soil moisture sensor, rain detector sensor and smoke detector sensor. The sensors are used to measure the current environmental conditions. Readings at different intervals of time is observed. Temperature sensor is used to measure the present temperature of the atmosphere. Humidity is used to measure the content of moisture present in air. Soil moisture sensor measures the water content in the soil and supplies water if needed. Rain detector sensor is used to detect rainfall. Smoke detected sensor is used to detect the presence of gas in air, the led on the sensor glows as soon as the smoke is detected. As soon as smoke is detected the buzzer beeps.



Figure 2. Hardware of the system

### 6. RESULT

#### 6.1 Web page input window



Figure 3. web page input window

We have developed the website of greenhouse monitoring system as shown in figure 10.1. This web browser displays a web page on a monitor or mobile device. On a network, a web browser can retrieve a web page from a remote web server. This web server is used access a private network such as a corporate intranet. The web browser uses the Hypertext Transfer Protocol (HTTP) to make such requests to the web server.

#### 6.2 Web page output window

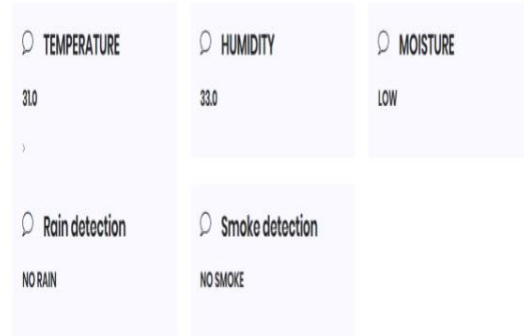

Figure 4. web page output window

The figure 10.2 gives us the webpage result. We can observe the current climatic conditions in the green house on the webpage. One can watch it from anywhere with internet of things. Green house monitoring system provides advanced system for farmers. Every time the sensors sense the climatic conditions it is displayed on this webpage. The refresh time is about 10 seconds. The changes in temperature, humidity, moisture, rain detection and smoke detection are displayed on this page.

#### 6.3 Experimental result

Date: 3/01/2019					
Time	Temperature	Humidity	Soil moisture	Rainfall detection	Smoke detector
1	29	32	Low	Raining	No smoke
2	33	39	High	Raining	Smoke detected
3	36	42	High	No rain	Smoke detected
4	30	66	Low	Raining	No smoke
5	28	60	Low	No rain	No smoke
6	27	35	Low	No rain	Smoke detected
7	31	45	High	No rain	Smoke detected
8	36	38	Low	Raining	No smoke
9	32	40	High	Raining	No smoke
10	29	30	High	No rain	Smoke detected

Figure 5. experimental result



## 7. CONCLUSION

This system describes the design of green house monitoring system based on IoT using Raspberry Pi. The IoT will dramatically change way we live our daily lives and what information is stored about us. This monitoring system perceps different parameters inside the greenhouse using sensors. The parameters such as temperature, humidity, soil moisture and rain detectors are under control. The developed system can be proved profitable as it will optimize the resources in the greenhouse. The complete module is of low cost, low power operation hence, easily available to everyone. This system can be installed by any individual in his house, who doesn't have knowledge about farming. Since one can maintain any climatic condition in this type of greenhouse, it is possible to cultivate any type of crop. Most importantly, we are able to connect farmer directly to consumer using IoT, which can save him from clutches of middleman. It reduces effort and time of farmer and makes farming efficient and profitable activity.

## 8. REFERENCES

- [1] Ravi Kishore Kodali, Vishal Jain and Sumit Karagwal Department of Electronics and Communication Engineering National Institute of Technology, Warangal. *IoT based Smart Greenhouse* Region 10 Humanitarian Technology Conference (R10-HTC) IEEE 2016.
- [2] Sheetal vatari; Aarti Bakshi; Tanvi Thakur *Greenhouse by using IOT and Cloud Computing* IEEE 2016.
- [3] Akshay D. Deshmukh; Ulhas B. Shinde *A low cost environment monitoring system using raspberry Pi and arduino with Zigbee* International Conference on Inventive Computation Technologies. (ICICT) volume 3,2016.
- [4] S. G. Nikhade, *Wireless sensor network system using Raspberry Pi and zigbee for environmental monitoring applications*, "Smart Technologies and Management for Computing, Communication, Controls, Energy and Materials (ICSTM), 2015 International Conference on, Chennai, 2015,pp. 376-381.
- [5] Mohannad Ibrahim; Abdelghafor Elgamri; Sharief Babiker; Ahmed Mohamed *Internet of things based smart environmental monitoring using the Raspberry-Pi computer* Fifth International Conference on Digital Information Processing and Communications. (ICDIPC) 2015.
- [6] Nagaraj Patil, Anand K Warad. *IOT and Raspberry PI Based Environmental Monitoring Application* Dept. of Electronics And Communication Environmental Wireless Sensor Networks. ISSN (Online): 2347-2820 Volume -4, Issue-4, 2016.
- [7] Remya Koshy, M D Yaseen, *Greenhouse Monitoring and Control Based on IOT Using WSN* Dept. of Electronics and Communication Engineering, RRCE, Bangalore. Vol.4, Issue 3, 2016.
- [8] Imran Bin Jafar; Kanij Raihana; Sujan Bhowmik; Shifur Rahman Shakil *Wireless monitoring system and controlling software for Smart Greenhouse Management* International Conference on Informatics, Electronics & Vision (ICIEV) 2014.
- [9] I. F. Akyildiz, Weilian Su, Y. Sankarasubramaniam and E. Cayirci, *A survey on sensor networks*, in IEEE Communications Magazine, vol. 40, no. 8, pp. 102-114, Aug 2002.