

# Optimal Design and Analysis of a Stringer-Stiffened Composite Payload Adapter

Pavithra V.<sup>1</sup>, Balamurali A. G.<sup>2</sup>, Dr. Gangadhar Ramtekkar<sup>3</sup>

<sup>1</sup>M Tech. Structural Engineering, NIT Raipur

<sup>2</sup>Scientist/Engr. S'G', SMD, VSSC, ISRO

<sup>3</sup>Professor, Dept. of Civil Engineering, NIT Raipur

\*\*\*

**Abstract** – Composite materials which have proved their importance in weight sensitive applications like aerospace structures can exhibit their efficiency only when appropriately distributed in shape and material orientation. Thus, an optimal design involves obtaining the best possible shape, dimensions, and material orientation which satisfies a set of design constraints which is attained by maximizing or minimizing an objective function. In this paper, the optimization is performed by an iterative technique of mass minimization. A payload adapter is basically an interface between the payload and the launch vehicle. The reduction of mass of a payload adapter allows subsequent increase in the mass of the payload as the sensitivity is 1:1. Here, the optimal design with minimum mass is arrived at, which at the same time should be able to meet the stiffness and strength requirements during the entire journey of the flight. The design of a Stringer-stiffened composite payload adapter and its comparison with the Monocoque structure is covered in this paper. Static strength, stiffness and buckling resistance of the structure is ensured in the design. The amount of weight savings achieved by designing these structures using laminated composites compared to the metallic version is reported. The finite element modeling and design is performed in MSC. NASTRAN.

**Key Words:** Composite, Laminate, Payload Adapter, Monocoque, Stringer-stiffened

## 1. INTRODUCTION

In spaceflight, a launch vehicle performs the task of transferring the payload or the satellite in to the earth's orbit. A payload adapter (PLA) is a structure which connects the payload to the launch vehicle body [1]. As there is a strong need in reducing the weight of the structural parts of a launch vehicle, composites are widely used in this application. For aerospace applications, design for minimum weight/mass is formulated primarily to reach the best structural performance rather than to save the material [2]. Reduction of structural mass is important in many ways – it helps to increase payload mass and thus reduce the launch cost [3]. Carbon-epoxy composite materials have been used extensively in upper stage structures of launch vehicles in order to improve the payload capability [4]. Although CFRP is superior to metals or other isotropic materials in specific strength and modulus, this advantage is only in the fiber

direction [5]. There comes the relevance of an optimal design. An exploded view of the upper stage of the launch vehicle showing the PLA is shown in fig. 1.

### 1.1 Monocoque Structure

A Monocoque structure is basically a thin-walled shell structure in which the load is transferred directly through the external skin. It doesn't have any stringers to stiffen the structure. Here, the structure is designed by iteratively changing the thickness and the orientation of the skin to arrive at the minimum thickness of the shell required to meet the design constraints. The structure has an advantage of ease of manufacturing compared to the other stiffened constructions.

Here, two types of Monocoque constructions are compared- first one made with Aluminium skin and second one made with laminated composites, both satisfying the same design constraints.

### 1.2 Stringer-Stiffened Structure

The Stringer-stiffened structure consists of a thin face sheet stiffened by uniformly and closely spaced ribs called stringers. The stringers are closely attached to the skin so that they act as a single unit (fig. 2). Here, the stringers are provided with hat section.

In the metallic version, both the stringers and the face sheet are made of Aluminium. In the composite version of the structure, both the stringers and the face sheet are made of M55J/M18 CFRP laminates. The optimum design in both the cases are found out.

## 2. CONFIGURATION OF THE PLA

As the PLA is a structure which connects the payload and the launch vehicle having different diameters, it is in the shape of a truncated cone having fore end diameter 937 mm and aft end diameter 1400 mm. The height of the structure is 1000 mm. The configuration of the PLA is shown in fig. 3. It has metallic rings at both the ends, riveted and bonded to the cone to form the interface attachment rings. The fore end of the PLA joins with the satellite and the aft end flange provides interface with the launch vehicle core.

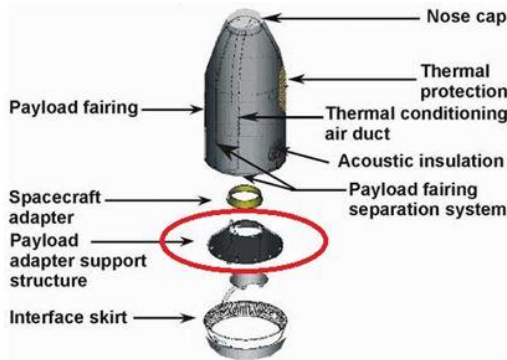

**Fig - 1:** Exploded view of Upper stage of Launch Vehicle showing PLA

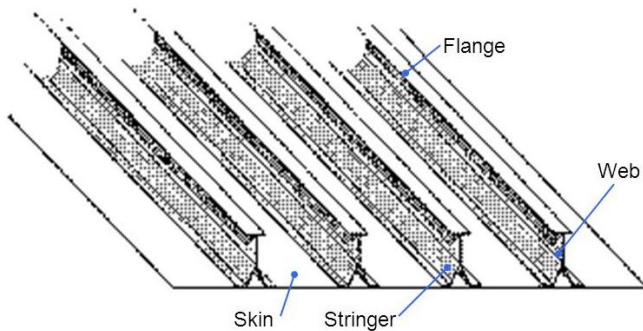

**Fig - 2:** Skin-Stringer Assembly

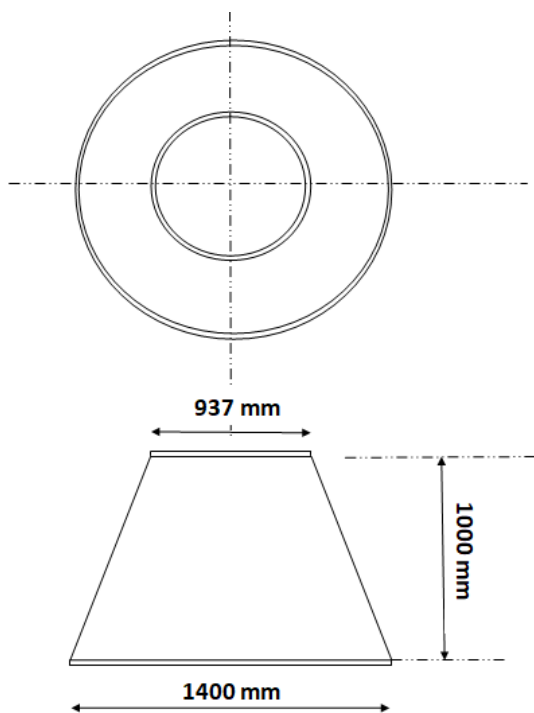

**Fig - 3:** Configuration of PLA

### 3. DESIGN CONSIDERATIONS

Any structure is designed to withstand the loads acting on them during the entire period of their life. Here, a factor of safety of 1.25 is provided as in all aerospace designs. The design loads acting on the structure are given in table 1. The satellite details are given in table 2. The structure is checked for axial stiffness, static strength and also buckling resistance.

The lateral and axial frequency of the structure with the satellite mass and inertia simulated and all the degrees of freedom at the aft end arrested shall not be less than 15 Hz and 30 Hz respectively. This criterion shall be met to avoid dynamic coupling. The stresses generated in the structure should be within the yield strength value of the material. The buckling load factor of the structure with a knock down factor of 0.6 and design factor of safety of 1.25 applied should be greater than 1. A structure which satisfies all the above conditions and having a mass less than 25 kg is taken as the optimum one.

**Table 1:** Loads acting on the PLA

Mass of the payload (Satellite)	3500 kg
Axial load	300.43 kN
Lateral load	128.76 kN
Equivalent axial load	1255.3 kN
Bending Moment	327.04 kN m

**Table 2:** Satellite Mass and Inertia

Mass of the satellite	3500 kg
Height of satellite C.G. above its base	1.5 m
Moment of inertia about axial axis	1500 kg-m <sup>2</sup>
Moment of inertia about lateral axis	3000 kg-m <sup>2</sup>

### 4. FINITE ELEMENT MODELLING

The finite element modeling was done in MSC. PATRAN. The Monocoque configuration was modeled using the 2-D shell elements of PATRAN. In the stringer stiffened structure, the skin was modeled using 2-D shell elements and the stringer was modeled using 1-D beam elements. The discretized model of a Monocoque PLA with rigid link attached on the top is shown in fig. 4. The finite element model of a stringer-stiffened PLA is shown in fig. 5.

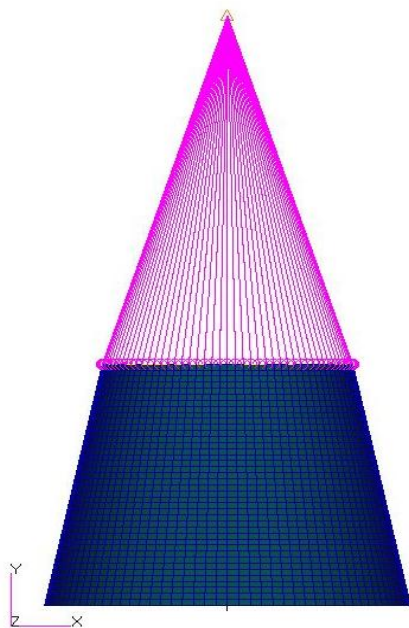

Fig - 4: Finite Element Model of a Monocoque Structured PLA with Rigid link mounted on the top

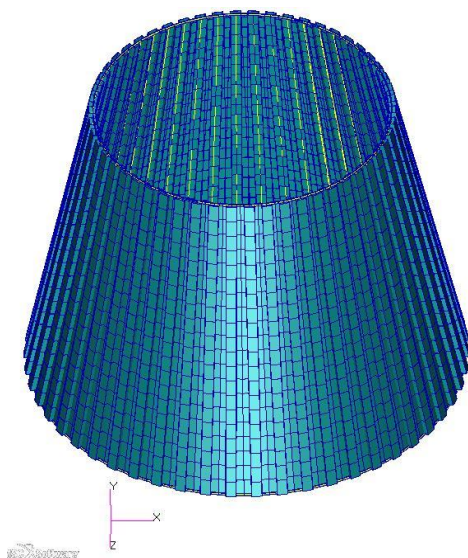

Fig - 5: Finite Element Model of a Stringer-Stiffened PLA

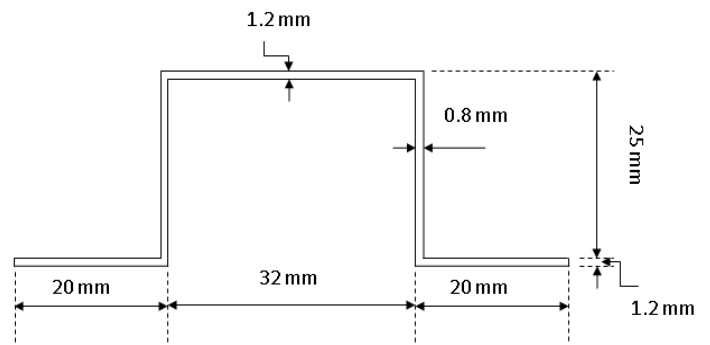

Fig - 6: Cross-sectional Details of the Stringer

## 5. DESIGN AND ANALYSIS

The design approach used here is design through analysis. The two configurations studied here are Monocoque and Stringer-stiffened. Static, free vibration and buckling analyses are carried out for both these structures. In the static analysis, the aft end nodes of the PLA are fixed and the design loads as given in table 1 are applied at the C.G. of the satellite which is transferred to the fore end nodes by using a rigid link. In the free vibration analysis also, the aft end nodes are fixed and fore end nodes mounted with a rigid link. In the buckling analysis, equivalent axial load is uniformly applied on the fore end nodes whereas the aft end nodes are fully fixed.

### 1.1 Monocoque Structure

In the metallic version of Monocoque configuration, the thickness of the Aluminium skin is iteratively increased from 1 mm till that minimum thickness which satisfies all the design constraints. Thus, the optimum thickness of Aluminium sheet required was found to be 6 mm. The mass of the structure was found to be 62.35 kg.

In the case of laminated Monocoque, the number as well as the orientation of the M55j/M18 prepreg laminates was changed iteratively to obtain the optimum design. The design consist of 45 laminate layers in the following orientation with respect to the axis of the PLA - 0/0/90/90/0/90/0/-90/0/45/0/-45/0/90/0/-90/0/-45/45/0/90/0/45/0/90/0/45/-45/0/-90/0/90/0/-45/0/45/0/-90/0/90/0/90/90/0/0. The mass of the structure was found to be 30.31 kg. The contour plots of Monocoque structure under buckling and free vibration analysis are given in fig. 7 to 10.

### 1.2 Stringer-Stiffened Structure

In the Stringer-stiffened structure constructed with Aluminium sheet, the thickness of the face sheet as well as the number of the stringers is varied to find the optimum design. The cross-section of the stringers used are given in fig. 6. The optimum number of stringers was found to be 48. and the thickness of the face sheet is 4 mm. In the laminated design, the thickness as well as the orientation of the

laminated layers of the face sheet and the stringers were varied iteratively to obtain the optimum design. The number of stringers were also varied.

The optimum number of stringers in the laminated design of stringer stiffened structure is obtained as 64. The optimum thickness of the face sheet is obtained as 1.5 mm. The layup sequence of the face sheet with respect to the axis of the shell is -0/-60/0/-90/-90/90/60/0/60/90/-90/-90/0/-60/0 and the layup sequence of the stringer with respect to the axis of the shell is -0/-45/0/45/0/90/90/0/45/0/-45/0. The contour plots of Stringer-stiffened structure under buckling and free vibration analysis are given in fig. 11 to 14.

**Table 3:** Results of Free Vibration and Buckling Analysis of Monocoque Structure made of Aluminium skin

Mode	Natural Frequency	Buckling Load Factor
1	18.15	1.04
2	18.15	1.04
3	52.54	1.27
4	95.40	1.27
5	95.40	1.64
6	98.48	1.64
7	245.80	1.73
8	245.80	1.73
9	257.38	2.08
10	257.38	2.08
Mass of PLA		62.35 kg

**Table 4:** Results of Free Vibration and Buckling Analysis for Monocoque Structure with Laminated skin

Mode	Natural Frequency	Buckling Load Factor
1	22.62	1.00
2	22.62	1.00
3	36.81	1.15
4	69.43	1.15
5	69.43	1.46
6	123.04	1.46
7	278.70	1.77
8	278.70	1.77
9	291.26	1.78
10	291.26	1.78
Mass of PLA		30.31 kg

**Table 5:** Results of Free Vibration and Buckling Analysis of Stringer-Stiffened Structure made of Aluminium skin

Mode	Natural Frequency	Buckling Load Factor
1	16.77	1.03
2	16.77	1.03
3	43.09	1.35
4	79.08	1.35
5	79.08	1.47
6	93.11	1.47
7	292.59	1.85
8	292.59	1.85
9	293.34	2.37
10	293.34	2.37
Mass of PLA		55.10 kg

**Table 6:** Results of Free Vibration and Buckling Analysis of Stringer-Stiffened Structure made of Laminated Composite

Mode	Natural Frequency	Buckling Load Factor
1	16.88	1.08
2	16.88	1.08
3	21.77	1.10
4	42.36	1.10
5	42.36	1.19
6	97.73	1.19
7	393.20	1.19
8	393.20	1.19
9	393.26	1.19
10	393.26	1.19
Mass of PLA		21.79 kg

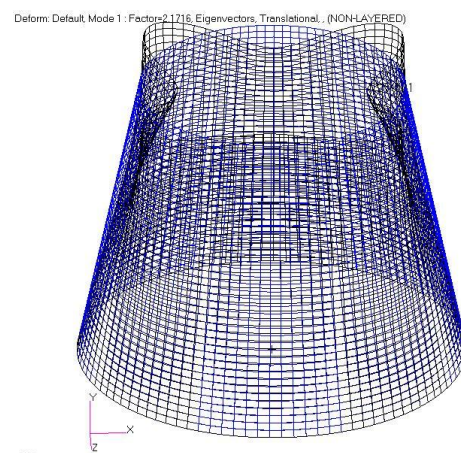

**Fig - 7:** First Buckling Mode of Monocoque Structure made of Aluminium skin

Deform: Default Mode 1.Freq.=18.154, Eigenvectors, Translational, (NON-LAYERED)

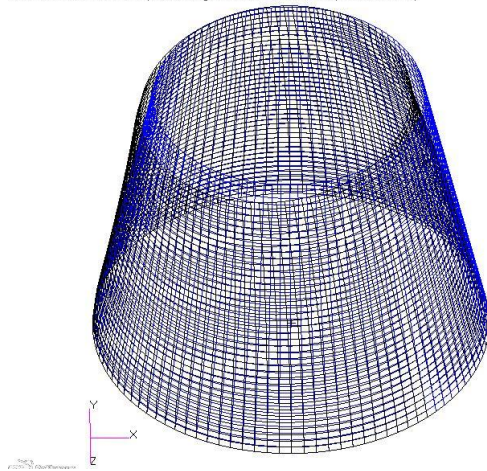

**Fig - 8:** Lateral Mode of Monocoque Structure made of Aluminium skin under Free Vibration

Petran 2016 10-Apr-19 10:37:29

Deform: Default Mode 1 Factor=2.1491, Eigenvectors, Translational, (NON-LAYERED) 1.27-001

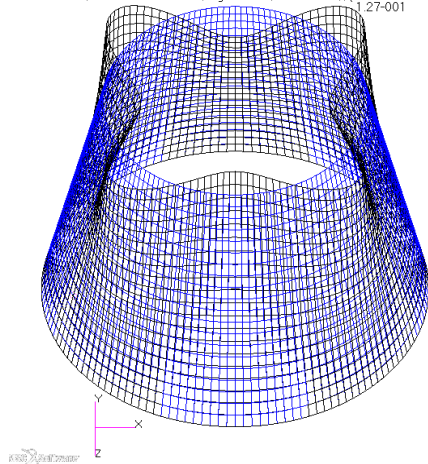

**Fig - 11:** First Buckling Mode of Stringer-Stiffened Structure made of Aluminium skin

Deform: Default Mode 3.Freq.=36.808, Eigenvectors, Translational, (NON-LAYERED)

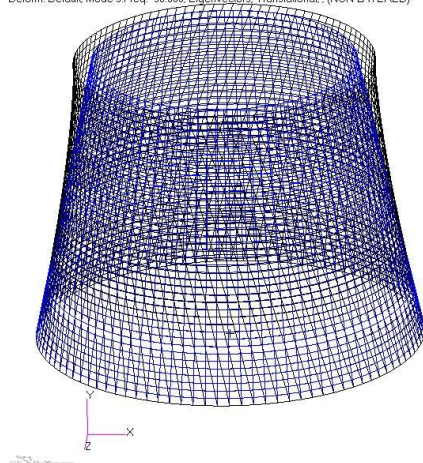

**Fig - 9:** Torsional Mode of Monocoque Structure with Laminate skin under Free Vibration

Petran 2016 07-Mar-19 10:23:55

Deform: Default Mode 2.Freq.=16.766, Eigenvectors, Translational, (NON-LAYERED)

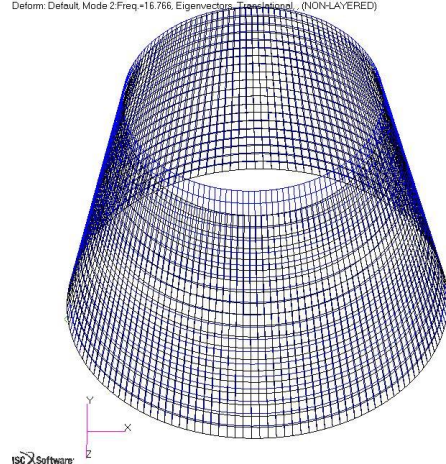

**Fig - 12:** Lateral Mode of Stringer-Stiffened Structure made of Aluminium skin under Free Vibration

Deform: Default Mode 4.Freq.=69.433, Eigenvectors, Translational, (NON-LAYERED)

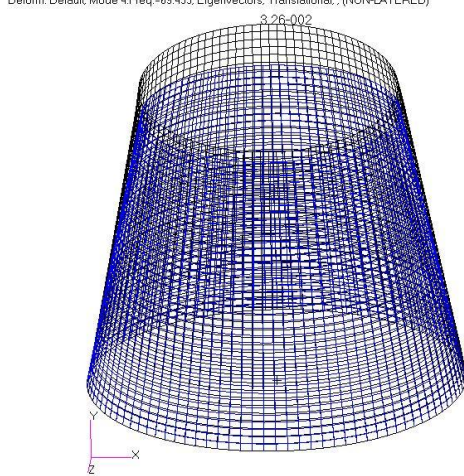

**Fig - 10:** Axial Mode of Monocoque Structure with Laminate skin under Free Vibration

Petran 2016 14-Mar-19 12:08:32

Deform: Default Mode 6.Freq.=97.734, Eigenvectors, Translational, (NON-LAYERED)

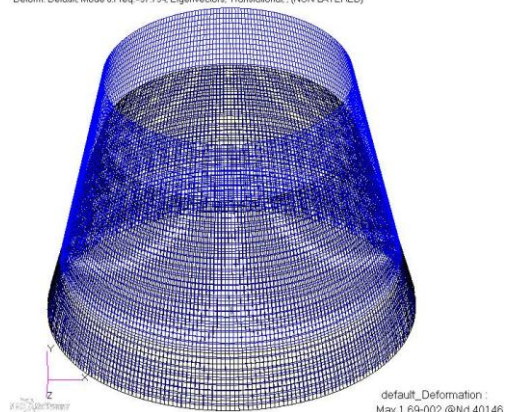

**Fig - 13:** Axial Mode of Stringer-Stiffened Structure with laminate skin under Free Vibration

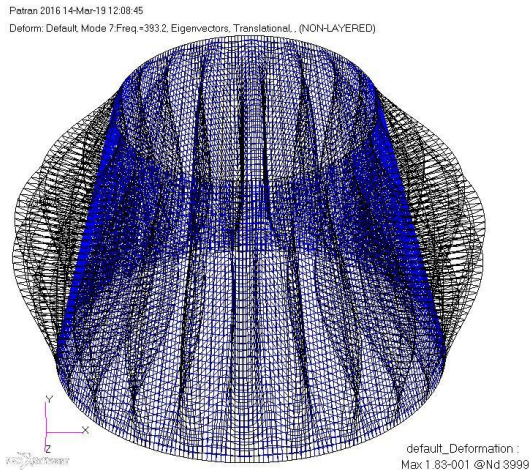

**Fig - 14:** Shell Mode of Stringer-Stiffened Structure with Laminate skin under Free Vibration

## 6. RESULT

The optimized structure in both the configurations were found out. The results of free vibration and buckling analysis of the optimum structures are shown in table 3 to 6. The stresses obtained in the structures were found to be within the permissible limits. The mass of the optimum structures were also found.

## 7. CONCLUSION AND DISCUSSION

It was found that in both the configurations, the use of composite reduced the mass of the structure more than 50% compared to the metallic structure. The Stringer-stiffened structure is found to be light-weight compared to the Monocoque structure. It was found to save 28% mass compared to the Monocoque structure.

## REFERENCES

- [1] A.F. Razinand V. V. Vasiliev. Development of composite anisogrid spacecraft attach fitting.
- [2] Valery V. Vasiliev and Zafer Gurdal, " Optimal design-Theory and applications to materials and structures"
- [3] Devika Venu, Alice Mathai, Jayasree Ramanujan, "Finite Element Analysis of Interface ring of a Rocket Launcher" ISSN: 23198753. www.ijirset.com, 2013
- [4] Nakumura T., "CFRP Application to Upper Stage Structure of Japan's Launch Vehicles", Proceedings of the Fourth Japan-US Conference on Composite Materials, pp. 923-932, 1988
- [5] Hosomura T., "New CFRP Structural Element", Japan-US Conference on Composite Materials, Tokyo, pp. 447-452, 1981