

# PROTECTION OF THREE PHASE INDUCTION MOTOR USING MICROCONTROLLER

Pornima Tilekar<sup>1</sup>, Nikita Walunj<sup>2</sup>, Pooja shinde<sup>3</sup>

<sup>1,2,3</sup>Students, Department of ENTC Engineering, JSPM, ICOER, Pune, India.

\*\*\*

**Abstract** - Induction Motor is used in industrial application in a wide range of operating areas because of their robust structure, high efficiency, low costs etc. So provide protection is very important in industrial application. The purpose of this project is providing the protection to Induction Motor in various applications. The main aim of our research is to protect the Induction Motor from over temperature, over vibration, dry and wet conditions and over voltages. This system design is based on Microcontroller. We use pic18f4520, different types of sensors are used for fault detection and a LCD display is used for faults occurrence.

**Keywords** - Microcontroller, Three Phase Induction Motor, LM35, ADXL335, Fault detection.

## 1. Introduction:

Induction Motor is one of the most important motors used in industrial applications. In industries 3-phase Induction Motors are the most common and frequently encountered machines. The electrically related faults like over-voltage, over-temperature, over vibration, etc.[1] Due to these faults the winding of motor gets heated which leads to insulation, failure and it reduces the life of the motor.[2] Because of this Induction Motor can cause plant shutdown, and waste of raw material. When supply voltage is higher than rated voltage then Induction Motor get overheated. When motor is running for a longer time under loaded condition then also motor gets heated. When vibration increased beyond rated value then also we have possibility of fault occurrence.[5] This fault is generated in motor due to variations in Induction Motor parameters. For this fault detection and protection of Induction Motor proposed system is designed using microcontroller.[8]Circuit is completely controlled by the PIC-Microcontroller. Small scale industries are unable to provide costly protection to the motor it will increase their capital cost. So we tried to implement cheap and compact design of Induction Motor against over voltage, over temperature, over vibration and dry condition. The advantage of the proposed system is low cost, simple design and high accuracy. The protection of induction motor with the help of different faults such as over temperature, over vibration, over voltage, dry and wet conditions. [4].

## 2. Proposed System:

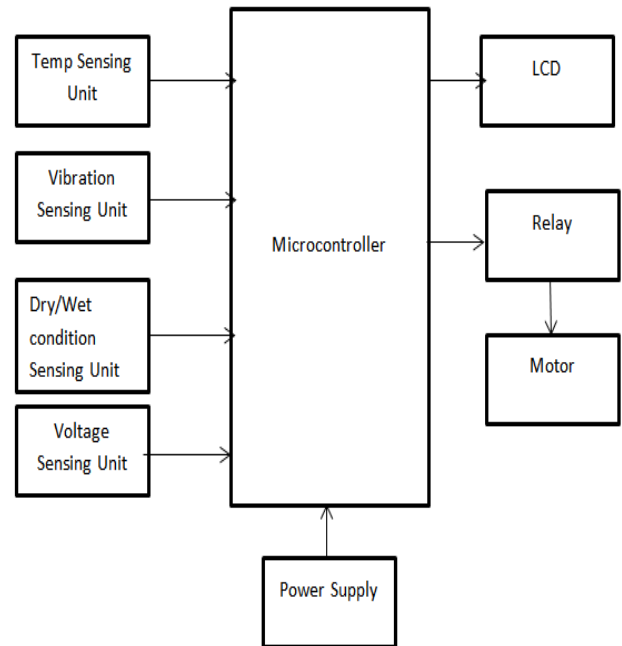

Fig1.1: Block diagram of proposed system

Microcontroller: PIC18f4520

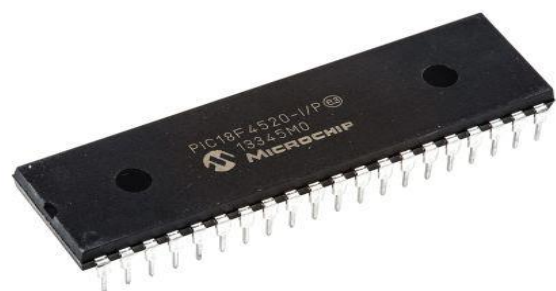

Fig2.2 Microcontroller PIC18f4520

### 2.1 Temperature sensing unit:

When the motor runs for long time under loaded condition of the motor and it gets heated over which reduces the efficiency of the motor. To sense over temperature, LM35 is used. This sensor provides 10 mv/°c output voltage proportional to the increased temperature of the motor. We set temperature value is 45°c. When temperature increases beyond 45°c then over

temperature is detected and display on LCD display screen and motor gets OFF.

**2.2 Vibration sensing circuit:**

In vibration sensing circuit we are using ADXL335 to sense the vibration. In this project we set the vibration range in between 50-200, when the vibration increases in the motor beyond the rated value then the coils or shaft of motor may get damage. Due to the increase in vibrations the motor gets heated up and causes harm. Also the coils in motor may get damage due to vibrations. In order to overcome this situation, the vibrations sensing circuit is used to protect motor from getting damage. When vibration gets increased then motor is turned off with the help of microcontroller.

**2.3 Dry and wet sensing unit:**

In dry and wet sensing unit we used level sensor. Purpose behind using this sensor is to protect motor from running without any load i.e. water. If motor is running without any load on it then coils in motor may get heated and it will cause damage to motor. If the level is high then it will be ok but if level is low then it will turn it off.

**2.4 Voltage sensing unit:**

The voltage sensing circuit using voltage divider circuit. The output from the step-down transformer is measured by this voltage sensing unit. The three phase supply voltage is given from the step-down transformer, and this output voltage is sensed and measured by voltage sensing circuit.

**2.5 Relay:**

Relay is a electro-mechanical device used to control high power application through low power signal electronic circuits, for an example a simple timer circuit working under 5V DC bias cannot control high voltage light bulb, by introducing Relay component we can easily control light bulb. In this project we are using SPDT relay.

**Hardware Setup:**

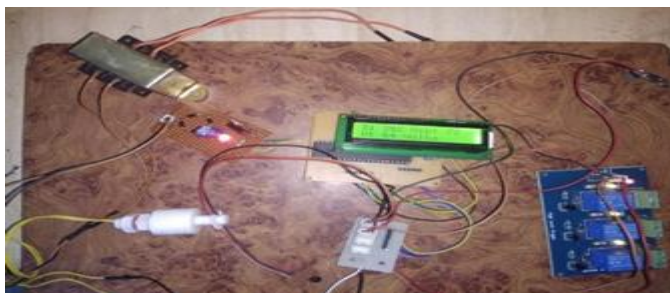

**Fig2.3 Hardware Setup**

**3. Program Algorithm:**

1. Start
2. Initialize LCD
3. Initialize all sensor
4. Check sensor data
  - a) If temp > offset value
    - Motor is off(Status while comparison)
  - b) If vibration > offset value
    - Motor is off(Status while comparison)
  - C) If level senses is LOW
    - Motor is off(Status while comparison)
5. Check motor condition
6. If fault detected
  - a) Remove fault
  - b) Press switch
7. Go to step 4.
8. Stop.

**4. Result:**

**4.1 Temperature sensing unit:** In temp sensing unit we set temperature value is 45°C. When temperature increases beyond 45 °c then over temperature fault is detected and display on LCD display screen and motor is turned off as shown in below figure.



**Fig4.1:Result of temperature sensing unit on LCD**

**4.2 Vibration sensing circuit:** In vibration sensing unit adxl335 sensor is used to sense over vibration in between 50-200. If it breaks down its range then motor gets off due to over-vibration.



**Fig4.2:Result of vibration sensing unit on LCD**

**4.3 Dry and wet sensing unit:** In dry and wet sensing unit we are using float sensor to sense dry condition.



**Fig4.3:Result of Dry and Wet sensing unit on LCD**

**4.4 voltage sensing unit:** Voltage sensing unit we are using voltage divider circuit to sense the over voltage. If voltage increase above its value then over voltage is detected and motor gets off.



**4.4:Result of Voltage sensing unit on LCD**

## 5. CONCLUSION

The Induction Motor have now turn into very popular as compared to other motor for number of the industries because of its low cost, high reliability, high efficiency, extremely rugged and simple construction, good power factor and low maintenance cost. Protection of Induction Motor is very important. Protection of three phase Induction Motor from overheating, overheating, over voltage, under voltage, and dry running give the smooth running of motor enhances its efficiency and lifetime. In three phase Induction Motor when running at rated voltage, current and load these fault are not created. For smooth running of motor by and large fixation on supply voltage under as far as possible and load which is driven by the motor to likewise be under as far as possible. The system is successfully implemented and tested. If any interruption is observed during motor operation, occurred fault is displayed on the LCD and motor stops.

## REFERENCES

- [1]. Malik Abadulrazzaq Alsaedi. –Fault Diagnosis of Three-Phase Induction Motor: A Review||. Optics Special Issue:Applied Optics and Signal Processing. Vol.4,o.1-1,2015,pp.1-8.doi:10.11648/j.optics.s.2015040101.11
- [2] S.Assly Steffy, B.mangaiyarkarasi, S.Sherin Jasper, K.Priyanka, K.Soorya –An Improvement in Winding Protection of Three Phase Induction Machine Using Solid State Relays||. International Journal of Advanced Research in Computer and Communication Engineering Vol. 3, Issue 2, February 2014
- [3] P.E. Elavenil , Dr. R. Kalaivani –Speed Monitoring And Protection Of Motor Using Zigbee Communication||

.International Journal of Scientific Research Engineering & Technology (IJSRET) Volume 2 Issue 11, February 2014.

[4] Ms. Patil Smita Jaywant, Mr. Patil Sachin sambhaji and Ms.Patil Pragati Deepak –Fault Detection and Correction of 3-phase Induction Motor||. International Journal of Advanced Research in Electronics and Communication Engineering (IJARECE) Volume 3, Issue 8, August 2014.

[5] Sumit Narwade, Prasad Kulkarni and C.Y.Patil –Fault Detection of Induction Motor UsingCurrent and Vibration Monitoring||. International Journal of Advanced Computer Volume-3 Number-4 -13 December-2013.

[6] K.K.Pandey, P.H.Zope, S.R.Suralkar, –Review on Fault Diagnosis in Three-Phase-Phase Induction Motor.|| International Journal of Computer Applications (IJCA) 2012.

[7] Oscar Poncelas, Javier A. Rosero, Jordi Cusidó, Member, IEEE, –Motor Fault Detection Using a Rogowski Sensor Without an . IEEE Transactions On Industrial Electronics, Vol. 56, No. 10, October 2009

[8] Prof Ms. Madhuri B. Zambre, Vivek V. Waiphale, Bhupali P. Kumbhar, “Microcontroller based protection and control of three phases IM,” IntJournal on recent and innovation trends in computing and communication, Vol 3, Issue 11. Nov. 2015.