

BIOMETRIC VEHICLE STARTER AND SECURITY

Madhavi Repe¹, Mayuri Kalhapure², Pratiksha Maske³, Aishwarya Nande⁴

^[1] Assistant Professor, Electronics and Telecommunication Department, Dr.D.Y.Patil Institute of Technology, Maharashtra, India.

^{[2][3][4]} Electronics and Telecommunication Department, Dr.D.Y.Patil Institute of Technology, Maharashtra, India.

Abstract: In this current world where technology is growing up day by day and scientific researchers are presenting new era of discoveries, the need for security is also increasing in all areas. At present, the vehicle usage is basic necessity for everyone. Simultaneously, protecting the vehicle against theft is also very important. Traditional vehicle security system depends on many sensors and cost is also high. When the vehicle is stolen, no more response or alternative could be available to help the owner of the vehicle to find it back. The main goal of this paper is to protect the vehicle from any unauthorized access, using fast, easy-to-use, clear, reliable and economical fingerprint recognition technique.

Key words: Bio-Metric, Ultrasonic Sensor, Keyless, Digitized, Fingerprint, Anti-theft.

1.INTRODUCTION:

Wheels have been the most important invention for mankind. These wheels led to the development of various vehicles which plays the vital role in displacement. In this era of development, usage of vehicle is at peak. With increasing mobility, vehicle theft has also become a serious issue.

To tackle this issue it is necessary to develop some secure access for the vehicle. Biometric access can be used for getting rid of unauthorized access to the vehicle.

Fingerprint sensors are quite cheap in comparison to other biometric sensors. And they are relatively easier to maintain also. The reason for going into biometrics is that its chances of being duplicated are very less. There are two main purposes for this project. First, being the eliminating the use of key completely for igniting the vehicle.

Further more security measures for the vehicle are also provided. This project can be implemented on any vehicle.

2.BLOCK DIAGRAM:

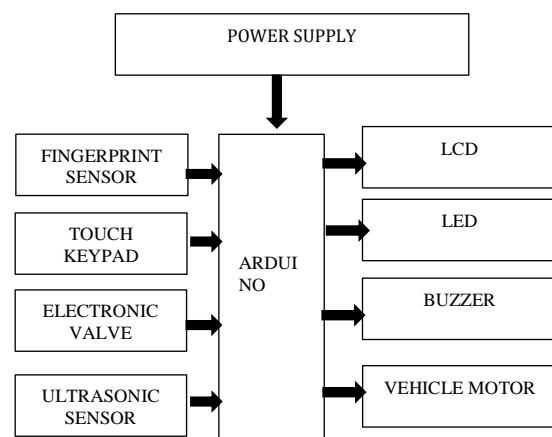

Fig-1. Block diagram of system.

3.WORKING:

In this paper, fingerprint module and keypad is used for providing security and easy access to vehicle. Without authorization vehicle cannot be accessed. In case fingerprint scanner fails, one can access the vehicle using keypad. More over timer is provided for automatic shutdown of system when the engine is in ON condition for a particular period of time but the vehicle is not in motion. Additionally, we are providing electronic switch to disconnect the power given to the spark plug when user don't want to access the vehicle, this will stop the engine and hence system will be locked and cannot be unlocked without authorization. Ultrasonic sensor is used to detect the height in case the vehicle is lifted and the user can be given an alert by using buzzer. Fingerprint sensor is preferred to use here because it is the most secured and easy to access as compared to other biometric devices. It is cost efficient as well.

4.BIOMETRIC SYSTEM:

The diagram below shows a simple block diagram of a biometric system. The main operations a system can perform are enrollment and test. During the enrolment biometric information of an individual are

stored, and during the test information are detected and compared with the stored information.

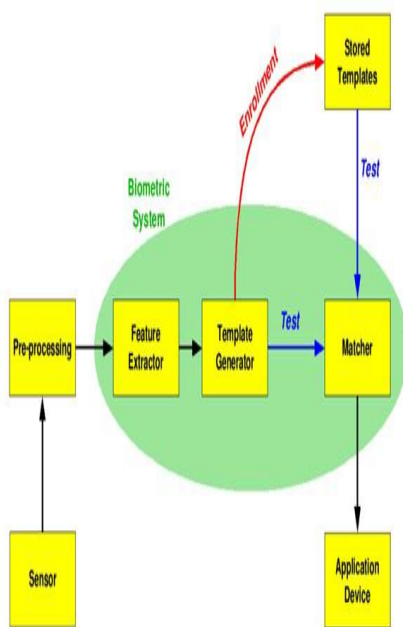

Fig-2. Biometric system.



Fig-3. Proposed vehicle with security features.

4.1.PATTERNS AND FEATURES:

The analysis of fingerprints for matching purposes generally requires the comparison of several features of the print pattern. These include print patterns, which are aggregate characteristics of ridges, and minutia points, which are unique features found within patterns. It is also necessary to know the

structure and properties of human skin in order to successfully employ some of the imaging technologies. There are three basic patterns of fingerprint ridges are the Arch, Loop, and Whorl.

ARCH PATTERN:

An arch is a pattern where the ridges enter from one side of a finger, rise in the centre forming an arc, and then exit the other side of the finger.

LOOP PATTERN:

The loop pattern is a pattern where the ridges enter from one side of a finger, from a curve, and tend to exit from the same side they enter.

WHORL PATTERN:

In the whorl pattern, ridges form a circular pattern around a central point on the finger. Scientists have found that of family members often share the same general patterns, leading to the belief that these patterns are inherited.

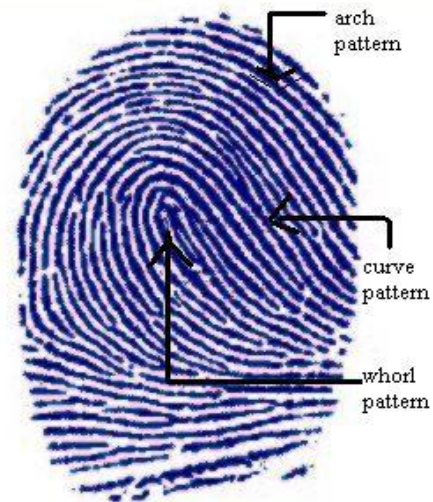

Fig-4. Human Fingerprint Pattern.

5.CIRCUIT DIAGRAM:

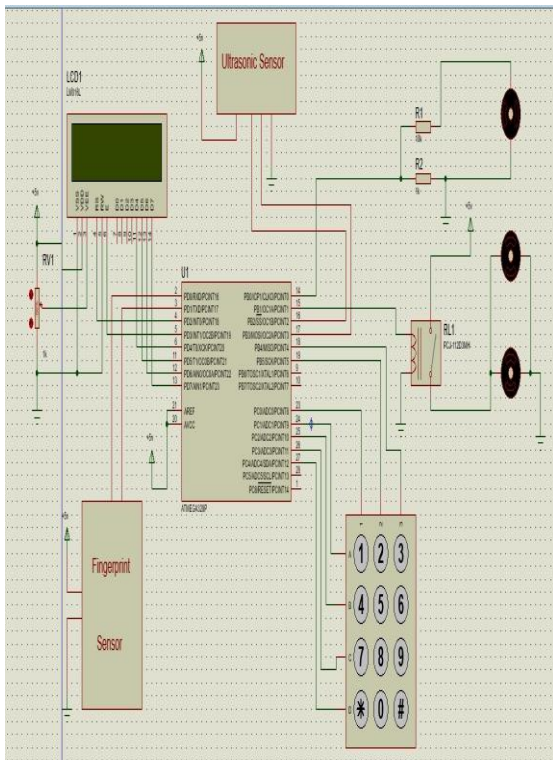

Fig-5. Circuit diagram of the system.

RESULT:

The result which we expect from our paper is that the vehicle will be ignited only when the authorized person scans his/her finger on the fingerprint module. The fingerprints of the authorized person(s) are stored in the fingerprint module. When any person put his/her finger on the fingerprint module then the data of the placed finger is matched with the stored data in the module. If the fingerprint data is found in the module then match condition occurs and the microcontroller ignites the vehicle otherwise vehicle will not start.

If the vehicle is moved beyond the threshold speed accelerometer sensor senses and the buzzer alerts the user.

CONCLUSION:

Hence a total security for the vehicle is assured. The developed security system will be fully digitized. A new affordable and user friendly system can be developed.

REFERENCE:

- [1] Safayetkhan , Obaidurrahman and MD.Ehsan, "Design and fabrication of a password protected vehicle security and performance monitoring system". 2017 IEEE region 10 humanitarian technology conference (r10-htc) 21 - 23dec 2017, Dhaka, Bangladesh.
- [2] Prabal Deep Das, Sharmilasengupta, **Implementing A Next Generation System To Provide Protection To Vehicles From Thefts And Accidents.** IEEE international conference on innovations in green energy and healthcare technologies (icight'17),2017.
- [3] N.N.Nagamma, Dr.M.V..Lakshmaiah, **Raspberry Pi Based Biometric Authentiationvehicle Door Lock System.** IEEE International Conference On Power, Control, Signals And Instrumentation Engineering (Icpci-2017).
- [4] Ronghuachen, Maryfenghua She, Xiangping Sun, Lingxuekong, **Driver Recognition Based On Dynamic Handgrip Pattern On Steeling Wheel.** 2011 IEEE.
- [5] Upendranrajendran and Albert JoeFrancis, **Anti Theft Control System Design Using Embedded System,** proc. IEEE.2011.
- [6] Vivekkumarsehgal **An Embedded Interface For Gsm Based Car Security System.** Department of cse & itjaypee university of information technology wagnaghat, solan, hp(India)IEEE, 2012.

BIOGRAPHIES:

Madhavi Repe presently working as Associate Professor at Dr. D.Y.Patil Institute of Technology, Pimpri-411018.
Email id: madhavirepe90@gmail.com



Pratiksha Maske pursuing B.E.(Electronics & Telecommunication) at Dr. D.Y.Patil Institute of Technology,Pimpri-411018.
Email id: pratiksha.msk@gmail.com



Mayuri Kalhapure pursuing B.E.(Electronics & Telecommunication) at Dr.D.Y. Patil Institute of Technology, Pimpri-411018.
Email id: ayurikalhapure22@gmail.com



Aishwarya Nande pursuing B.E.(Electronics & Telecommunication) at Dr. D.Y.Patil Institute of Technology,Pimpri-411018.
Email id: nandaishwarya8@gmail.com