

College Infrastructure Management System

¹Ankesh V. Singh, ²Vinod L. Gupta, ³Anand Yadav

^{1,2,3} Department of Electronics and Telecommunication, Thakur College of Engineering and Technology, Mumbai University

Abstract - Now a days, it is highly possible to adapt mobile computing in various applications. The portability, open source nature of smart phones and android development platform has made the development of application software for various environments as handy. Smartphone applications are resulted in paperless work, easy to use and time saving in nature. The wireless communication technology of smart phone enables the information transfer from the current client to remote database server, wherever the network range is available.

The College Infrastructure Management System is a mobile computing software application, which focuses on an activity or function, which is based on management of infrastructure of institutions. In this application we select a faulty accessories and report it to the admin with particular complaint. It maintains a database of all the information that are recorded and received. It helps the college to maintain all the accessories safely.

1.INTRODUCTION

The College Infrastructure Management System is a mobile computing software application, which focuses on an activity or function, which is based on management of infrastructure of institutions. In this application we select a faulty accessories and report it to the admin with particular complaint. It maintains a database of all the information that are recorded and received. It helps the college to maintain all the accessories safely.

India has the fastest growing telecom network in the world with many users moving towards SmartPhones and majority by students. Android is a reliable software development kit issued by Google in order to provide developers with a comprehensive set of tools for building Android applications. If used properly, the SDK(Software Development Kit) and JDK (Java Development Kit) is able to deliver state-of-the-art software for Android devices In other words, the SDK includes only the basic utilities for Android app development.

The information which we get from our mobile in a cost effective way & student and teacher can send information easily & quickly. So, it is time saving. Through this service one can send the complete information about the college infrastructure such as faults in a benches, in chairs, water problem, Fan and AC problem.

When admin get this information he can perform quick action to repair infrastructure of college. Also according to

students and teachers complaint he quickly know the location of accessories as classroom, canteen, library, etc. This application is mainly focus on the maintenance of college infrastructure.

1.1Scope of Project

The main scope of this application for managing the complaints, track the complaints easily just using one android application. We can use this android application in various places such as companies, schools, colleges, hospitals, libraries, etc. and in many more places. For placing their complaints regarding some issue and send it to the respective person who will handle this and find solutions for this complaints. After sending complaint user also can view status of their complaint either it will get solved or in a running condition etc. So this process normally we will use for solving complaints. So according to this our application is helpful in any area for solving complaints.

1.2Proposed Design

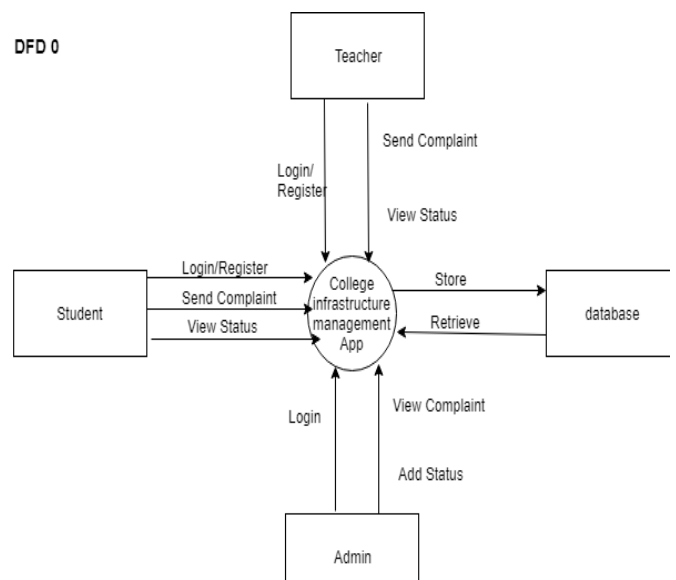
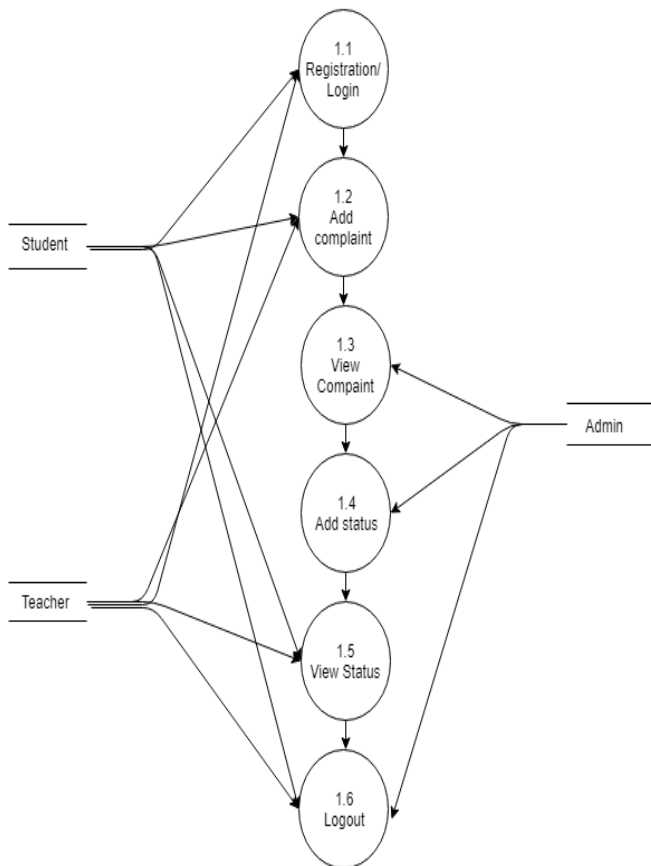

Fig1.1-Block diagram of college infrastructure system

1.3 FlowChart



2. Working principle

In this Android application 3 modules are included:

- 1) Admin
- 2) Student
- 3) Teacher.

This android application is based on the infrastructure of the college. Here student and teacher can write their complaint and send it to the admin on the mail with the place and name of the accessory.

Admin can view mail also he can view all the complaints in the android application. Admin update the status of complaint according to the work done. So student and teacher can track their complaints.

2.1 Software Required

The software required for such application development are:

A. Android studio:

Android studio is an open source and Linux-based operating system for mobile devices such as smartphones and tablet computers. Android was developed by the Open Handset Alliance, led by Google, and other companies. This tutorial will teach you basic Android programming and will also take

you through some advance concepts related to Android application development.

B. JDK 1.10

The Java Development Kit (JDK) is a software development environment used for developing Java applications and applets. It includes the Java Runtime Environment (JRE), an interpreter/loader (java), a compiler (javac), an archive (jar), a documentation generator (javadoc) and other tools needed in Java development.

People new to Java may be confused about whether to use the JRE or the JDK. To run Java applications and applets, simply download the JRE.

However, to develop Java applications and applets as well as run them, the JDK is needed. Java developers are initially presented with two JDK tools, java and javac. Both are run from the command prompt. Java source files are simple text files saved with an extension of .java. After writing and saving Java source code, the javac compiler is invoked to create .class files. Once the .class files are created, the command can be used to run the java program.

For developers who wish to work in an integrated development environment (IDE), a JDK bundled with Netbeans can be downloaded from the Oracle website. Such IDEs speed up the development process by introducing point-and-click and drag-and-drop features for creating an application.

There are different JDKs for various platforms. The supported platforms include Windows, Linux and Solaris. Mac users need a different software development kit, which includes adaptations of some tools found in the JDK.

C. Xampp Software:

XAMPP is an open source free software developed by Apache friends. XAMPP software package contains Apache distributions for Apache server, MariaDB, PHP, and Perl. And it is basically a local host or a local server. This local server works on your own desktop or laptop computer. You can just install this software on your laptop or desktop and test the clients or your website before uploading it to the remote web server or computer.

This XAMPP server software gives you suitable environment for testing MYSQL, PHP, Apache and Perl projects on the local computer. The full form of XAMPP is X stands for Cross-platform, (A)Apache server, (M)MariaDB, (P)PHP and (P)Perl. The Cross-platform usually means that it can run on any computer with any operating system.

The XAMPP installation process is very simple and fast. Once XAMPP is installed on your local computer it acts as a local server or localhost. You can test the websites before uploading it to the remote web server. This XAMPP server software gives you suitable environment for testing MYSQL, PHP, Apache and Perl applications on a local computer.

How to Use XAMPP for Development Process?

Once XAMPP installation is completed you can start and stop each module by using XAMPP Control Panel. For example, testing PHP applications on your computer, you can start the

two modules Apache and MySQL. It will allow PHP programs run on your computer. This XAMPP software emulates remote server like an environment on your local computer. As an app developer, you need to test applications as many times as possible to find and fix the bugs. If you are testing in the local environment like XAMPP, it will speed up your development process. Before XAMPP every time you need to upload files to a remote server for testing purpose. It will be quite difficult to test on the live server and it is visible to your visitors. But whereas in XAMPP you can easily test and make any updates in your localhost. At any number of times, you can update and test in XAMPP. Once completed you can upload this new updated files to the remote server. XAMPP contains tools such as Apache, MYSQL, PHP, and Perl. We will see about these tools.

a.Apache

Apache server is an open source free software which is initially developed by a group of software developers and now it is maintained by Apache software foundation. Apache HTTP is a remote server(computer) if someone request files, images or documents using their browser they will serve those files to clients using HTTP servers. Mainly hosting companies use this application to create a VPS server and shared hosting for their clients.

b.MYSQL

MYSQL is an open source software. It is actually a relational database management system(RDBMS). This SQL stands for Structured Query Language. It is the most popular and best RDBMS used for developing a variety of web-based software applications. With the help of MYSQL, it is possible to organize the information, manage, retrieve and update the data whenever you wish to do.

c.PHP

The full form of PHP is Hypertext Preprocessor. It is a server-side scripting language that helps you to create dynamic websites. This language is mainly used to build web-based software applications. It is an open source software and works fine with MYSQL. What actually happens is, the PHP code will be executed on the server and at the browser side its HTML code will be displayed.

3.RESULT

1.FrontView

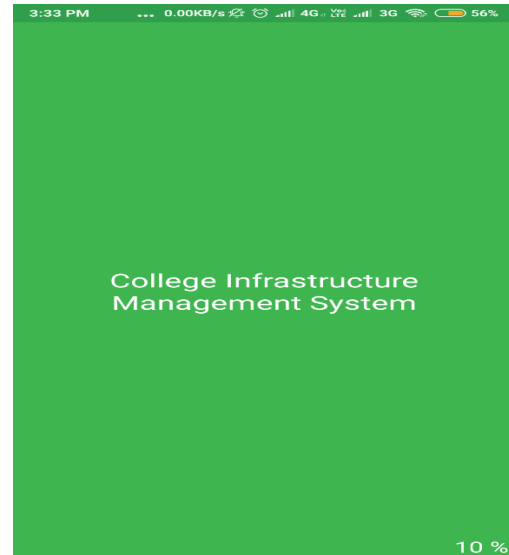

Fig3.1-Front View

2.Enter Sever IP Address

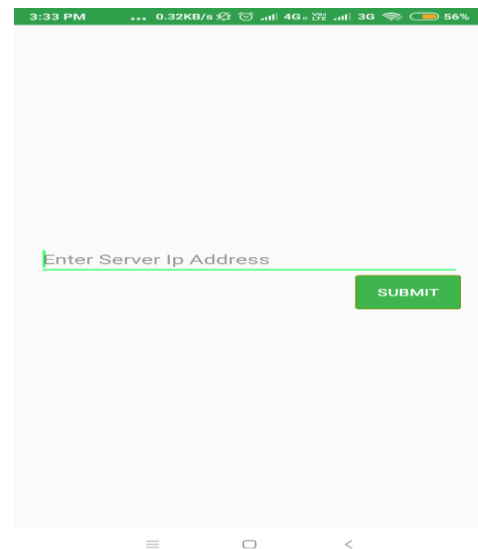

Fig3.2- Enter Sever IP Address

3. Login Page

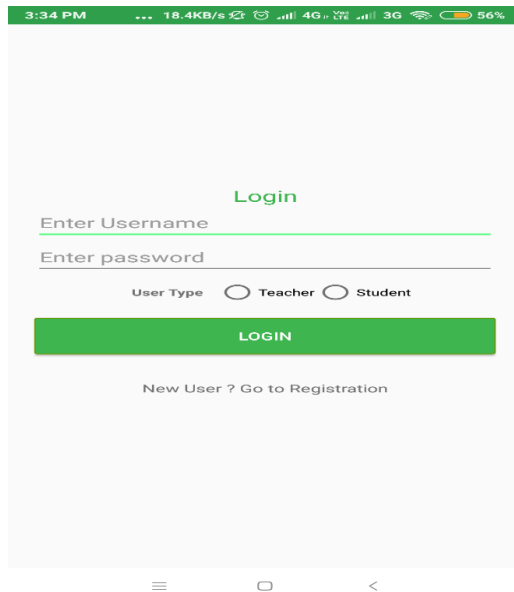

Fig3.3- Login Page

4. Registration Page

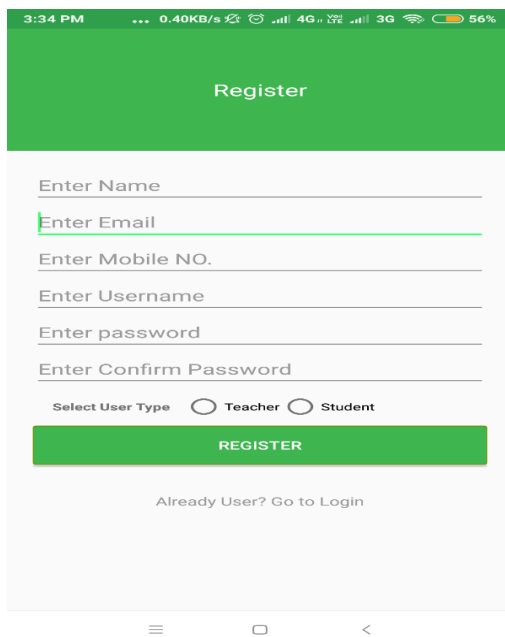

Fig3.4- Registration Page

5. Add Complaint

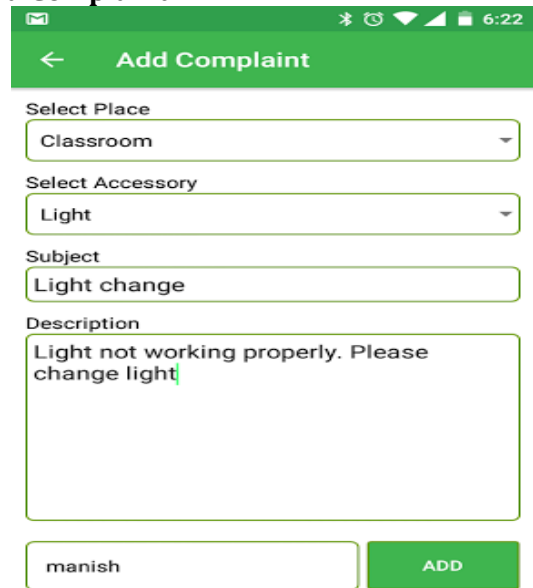

Fig3.5-Add Complaint

6.ViewComplaint

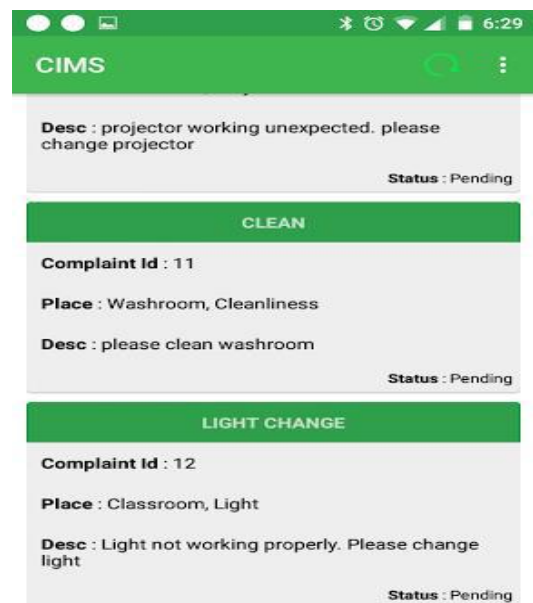

Fig3.6 ViewComplaint

7. Accept/ Reject Complaint

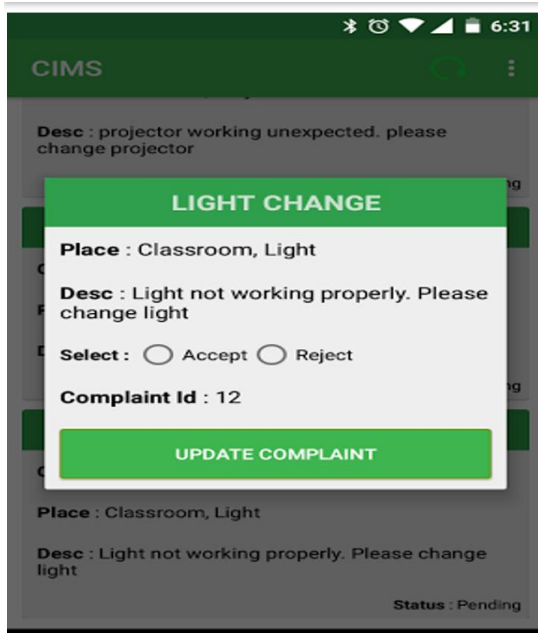

Fig3.7- Accept/ Reject Complaint

8. Track complaint

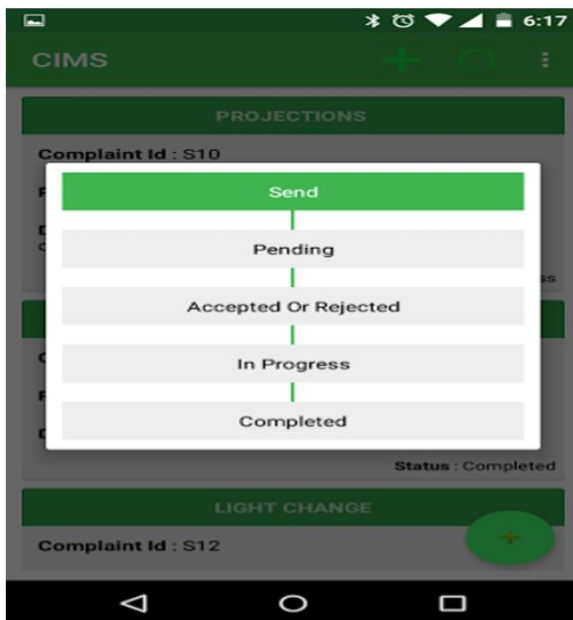

Fig3.8- Track complaint

4.References

[1] D.Vimala, A.Sindhu, S.K.Manikandan ,, "Developing an Android Application for College Management System", International Journal of Future Innovative Science and Engineering Res

[2] S.R.Bharamagoudar, Geeta R.B., S.G.Totad "Web Based Student Information Management System", International Journal of Advanced Research in Computer and Communication Engineering-June 2013, ISSN : 2319-5940.

[3] Shilpi, Taneja.,Goel, Anita. (2015). Mobile Applications in Educational Institutions.

[4] MobileAppDevelopment, <http://www.rapidsofttechnologies.com/androidapplicationdevelopment.html>.