

EXPERIMENT ON WORKING MODEL OF SELF BALANCING VEHICLE

Ashok B. Shyora¹, Rishabh R. Kanthariya², Dipesh N. Soni³, Raj C. Gangurde⁴

^{1,2,3,4}UG-Students-SSASIT, Mechanical Engineering Department

Abstract- The invention discloses a small-sized self-balancing scooter. The small-sized self-balancing scooter comprises a platform, two wheels arranged on the two sides of the platform correspondingly, and a direction control rod arranged on the platform. The small-sized self-balancing scooter further comprises two pedals arranged on the outer sides of the two wheels correspondingly. The pedals are connected with the small-sized self-balancing scooter through hinges. When the small-sized self-balancing scooter is in a non-riding state, the pedals on the outer sides of the wheels can be turned and folded through the hinges, so that the dimension of the scooter in the length direction is greatly reduced. Therefore, the size of the small-sized self-balancing scooter is reduced, and the small-sized self-balancing scooter can be conveniently carried by riders. Meanwhile, tires of the small-sized self-balancing scooter are arranged in a splayed manner, so that the wheel diameter of the wheels is increased on the basis of ensuring the whole size of the scooter, and the obstacle crossing capacity of the scooter is improved.

Keywords- Hoverboard, roller bearing, seat, battery, trolley

I.INTRODUCTION

With the development of science and technology, people's quality of life become increasingly demanding, in order to travel more convenient, a variety of means of transport in people's daily life, in addition to the requirements of a means of transport is easy to operate, saving , it is more convenient and efficient means of transport requirements.

For example impassable in some tourist attractions, business centers and other vehicles, electric cars and other vehicles; the more common white-collar workers from the subway station to the site-specific short-distance transportation, bicycles and other vehicles can not take the subway, and walking for too long, This requires a small, light weight, flexible hand over a new generation of tools, so self-balancing vehicle operators and students, but also by the people's favorite.

Early self balancing vehicle called photo-bit car (Segway), originally transliteration from abroad, is a power-driven, self-balancing ability of individuals to use transport vehicle, is a city with a vehicle. By the American inventor Dean Carmen (Dean Kamen) with his DEKA R & D Company (DEKA Research and Development Corp.) team invented the design, and the creation of photo-bit vehicle liability company (Segway LLC.), later renamed the Segway Company (Segway.1NC). Since December 2001 the car will be taken place commercial production and sales. However, this self-balancing vehicle larger, not suitable for China metro, attractions, shopping malls and other crowded places.

1.1 HISTORY

Some people think the Hover Lord invented the self balancing scooter but I can only take credit for being the best rider in the world and not the actual inventor.

This article on wired gives some interesting insight into the somewhat unknown origins of the self balancing scooter. In summary the article highlights how the rapid movement of technology in the Chinese manufacturing market makes it very difficult to attribute the device to one inventor.

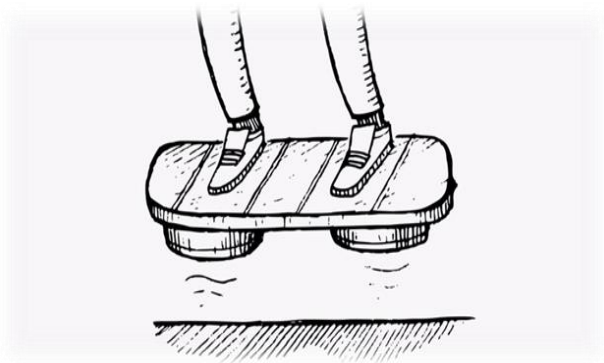

Figure 1: Oldest Hoverboard.

Again, the product as we see it today appears to be the amalgamation of work from many companies with several claiming to be the original without a clear winner to the independent observer. It also goes to show why you should be sure you do your research when buying a scooter to ensure you get a quality model without getting ripped off.

What history will show is that self balancing scooters first came to the attention of the world in 2014. They have since rapidly spread around the world as people begin to

unlock the potential use of the devices for fun and practical use.

1.2 AIM AND OBJECTIVE OF PROJECT

We are going to modify a self-balancing vehicle in such a way that a sitting arrangement is provided which is mainly useful for senior citizens as well as for each and every generation.

General aspect of Self Balancing Vehicle

- It's A Durable Transporter
- Easy To Use
- Following The Trend
- They're Fun!
- More Reliability
- Showing Off To Friends.
- The Hoverboard is Eco Friendly

Objective

- Easy Operating
- Easy balancing
- Transform one form to another
- Environment Controlling
- Low fuel consumption
- Sitting arrangement

1.3 BRIEF LITERATURE REVIEW AND PRIOR ART SEARCH ABOUT THE PROJECTS

According to our research work on web we came to know that a normal car battery having code 004 of 12 voltage having length 205, 175 width and 225 height which weights 14 kg approx.

The other car battery having code 005 of 12 voltage having 230 length, 175 width and 225 height which weights 16 kg approx.

1.4 PLAN OF THE WORK

Therefore, the size of the small-sized self-balancing scooter is reduced, and the small-sized self-balancing scooter can be conveniently carried by riders. Meanwhile, tires of the small-sized self-balancing scooter are arranged in a splayed manner, so that the wheel diameter of the wheels is increased on

the basis of ensuring the whole size of the scooter, and the obstacle crossing capacity of the scooter is improved.

Finally we are going to make a small sized self balancing vehicle which is easy to carry, portable, easy to drive with sitting arrangement.

1.5 MATERIALS AND TOOLS REQUIRED

We are going to use 4 supporting wheels of 6inch to 1 feet and 2 driving wheels of 6 inch in diameter and the motor is also fixed inside these 2 driving wheels.

The dimensions of base are 2 feet 6 inch*3 feet 6 inch made up of aluminium frame and Acrylic sheet.

The compact Japanese battery having 36 volt, of 4400 MAH. It will be dry cell mod of pattern and we just have to charge it. It is one of the compact battery available in our country with great efficiency.

II.EXPERIMENTAL STUDIES

SEGWALK-11 is a vehicle which is maily invented for the senior citizens and young generation also. It is so easy to take it wherever a person wants to take it.

It consist of hoverboard, sitting arrangement, a battery, roller bearing and it is made up of alluminium so that it proves to be durable, and having high sustanibility.

It works on the battery operated hoverboard, when we give a load to forward then it moves in ahead direction and when we give load to back ward direction then it moves to reverse direction.

There is a sitting arrangement on which a person can easily sit comfortably and drive it in a simple way.

It a portable and easy to drive and it have a battery of 3300mAh and can run upto 7 hours and can cover a distance of 17 km.

It can sustain weight upto 120 kgs and it is eco friendly and have zero emission and run on every kind of surface.

2.1 DESIGN SKETCH OF "SEGWALK-11"

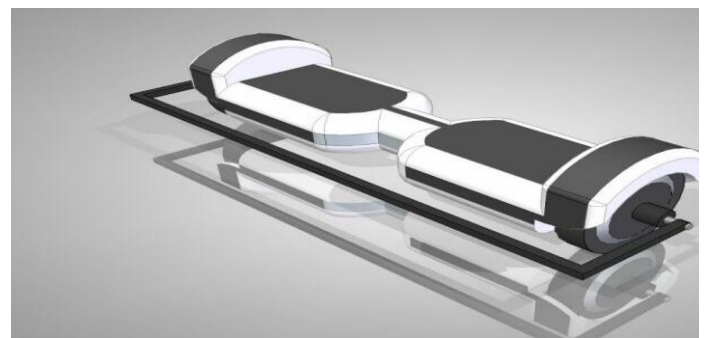

Figure 2: View of Hoverboard.



Figure 3: View of Sitting Arrangement.

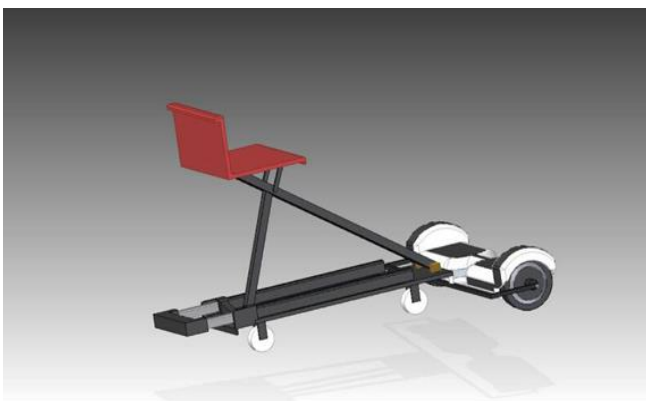

Figure 4: Side View of Segwalk 11.



Figure 5: Original Picture of Segwalk 11.

III. ADVANTAGE AND DISADVANTAGE AND FUTURE PLAN OF SELF BALANCING VEHICLE

Advantages:

1. Self-balancing boards have a modern or futuristic design, making them more appealing than the traditional skateboard.
2. Our self balancing vehicle get you places faster
3. Fun to ride

4. Cost a lot of money , but is really worth it
5. Substitute for bikes, motorcycles, cars, etc.
6. Can entertain you , instead of electronic
7. Walking is so last year. The productive prefer to use this self -balancing vehicle.
8. These self balancing vehicle are eco-friendly and run on a very low cost. These scooters work on rechargeable batteries with zero emission and they are almost noiseless. Obviously, these self-balancing scooters have enough power to run fast and cover large distances, and they can easily cover short distances without any issues.
9. These scooters are easy to operate and they are light-weight to carry around. They are low on maintenance costs and less accident prone. The lower power consumption aspect makes it a good choice.
10. These self balancing vehicle are an excellent alternative to bikes and motorcycles. This hoverboard is best for limited use. You can use this vehicle to shop for weekly groceries. You can take the self-balancing board to your office or fitness centers. It is a handy invention ideal for the urban adventure junkie.
11. Self-balancing scooters are one of the best creations of this era. It makes movement possible without too much exertion. You can use it in your house if you are lazy to take it around. These electrical scooters are the best vehicles to move if we want to keep this earth beautiful and safe.

Disadvantages:

1. Exploding Hoverboards
2. Accessibility
3. Availability
4. Steep hills
5. Can catch on fire

Future Plan:

- In future work, we can make our segwalk-11 more useful by providing hydraulic system and a joystick to move the wheels.
- It can also be more comfortable by changing the seat which will be more comfortable.

IV. CONCLUSION

This paper presents design and the development of the self balancing personal transporter which is capable of carrying single person to move from one place to another within the premises of large campus. The vehicle balances itself by moving the motors in clockwise or anti-clockwise direction base on the readings from sensors. Thus the proposed system can be much helpful in the large campuses like airports, universities etc. This system reduces the work of humans as well as provides eco friendly environment.

Reference

1. Shea, Ammon. "Hoverboard". Merriam-Webster. Retrieved 2016-02-16.
2. ^ Jump up to:^a ^b snope0s (4 November 2015). "Back to the Future Hoverboard : snopes.com". Snopes.
3. <https://en.wikipedia.org/wiki/Hoverboard> - cite_ref-3 Canadian Develops Futuristic Hoverboard. 13 October 2015 – via YouTube.
4. <https://www.youtube.com/watch?v=Bfa9HrieUyQ>
5. <http://www.guinnessworldrecords.com/world-records/116249-farthest-flight-by-hoverboard>
6. "Exhibits: Hiller Flying Platform".
7. "The Hover Board: How Close Are We?".
8. "Arbortech Industries Limited Airboard page". Archived from the original on July 20, 2001.
"Arbortech releases Airboard Series II"
9. "Hoverboard Project Takes Flight--and Actually Hovers". TechHive. 27 May 2010.
10. "Le Mag Surf- Université Paris Diderot- Paris 7". univ-paris-diderot.fr.
11. Anthony, Sebastian. "HUVr: The Back to the Future hoverboard is finally here". Ziff Davis, LLC. Retrieved 4 March 2014.
12. "Funny Or Die is Sorry for Lying about Hoverboards". Retrieved 5 March 2014.
13. Sean Buckley (2010-10-21). "We rode a \$10,000 hoverboard, and you can too". Engadget.
 1. Hendo Hover (2014-10-21). "Hendo Hoverboards - World's first REAL hoverboard". Kickstarter.
 2. Conor Dougherty (2014-10-21). "Hoverboard? Still in the Future". The New York Times.
 3. Kevin Lynch (22 May 2015). "Video: Watch incredible footage of farthest flight by a hoverboard record set by Canada's Cătălin Alexandru Duru". Guinness World Records. Retrieved 22 May 2015.
 4. <https://en.wikipedia.org/wiki/Hoverboard> - cite_ref-18 Andrew Liszewski. "Wait a Minute, Did Lexus Actually Make a Working Hoverboard?". Gizmodo. Gawker Media.
 5. <https://en.wikipedia.org/wiki/Hoverboard> - cite_ref-19 "HOVERBOARD IS a 2015 REALITY : IT'S CALLED LEXUS SLIDE !!!". CROSS BOARD RIDING FOR ANY RIDER RIDESUPBOARDS.COM.