

# Mini IR Radar for unauthorized object detection

Pradnya Kamble<sup>1</sup>, Tejashri Ghatage<sup>2</sup>, Swapnali Choudhari<sup>3</sup>

*Pradnya Kamble<sup>1</sup>, Department of ENTC Engineering, SGI, Atigre, Kolhapur, Maharashtra  
Tejashri Ghatage<sup>2</sup>, Department of ENTC Engineering, SGI, Atigre, Kolhapur, Maharashtra  
Swapnali Choudhari<sup>3</sup>, Department of ENTC Engineering, SGI, Atigre, Kolhapur, Maharashtra*

\*\*\*

**Abstract** - The purpose of this paper is to present Mini IR Radar for unauthorized object detection using IR sensor. More precise definition of radar is that it is a system used for recognition of target objects by transmitting IR signal, receiving reflection from target objects within its volume of coverage and extracting information such as distance and angle. The system can monitor an area of limited range and alert the authorities with a buzzer and LCD screen for monitoring a PIC controller circuit that is connected to an IR sensor mounted on a stepper motor for the detection status. As soon as an object is detected the radar system will detect the distance as well as the angle and display it on the LCD screen. After detecting that particular object after certain time span the motor will continue to rotate till next object is detected.

**Key Words:** Object Detection, PIC Controller, IR Sensor, Stepper Motor, LCD Display

## 1. INTRODUCTION

Radar is an object detection system that uses radio waves to determine the range and the angle. It can be used to detect aircraft, ships, spacecraft, guided missiles, motor vehicles and for whether formation. A radar system consists of transmitter producing electromagnetic waves in the radio or microwave domain and emitting antenna and receiving antenna to capture any returns from objects in the path of emitted signal. IR radar is an application of automotive radar where this type of IR radar is operating by sending IR signal to make scanning actually with small range. The goal of this paper is to create working of IR radar system to detect close target at an angle of 360 degrees with range upto 100cm.

### 1.1 Literature Survey

The research conducted for object detection in radar system is discussed in this paper. In this section, only the representative radar system are discussed for better understanding of the fundamental concepts of radar. Object detection has a lot of application in real world. Object detection is important where entry is banned for human being and to the robots etc. Therefore object detection of wide areas requires a system with the ability to detect objects through various angles. To overcome the related problem described above, this paper proposed a new technique for object detection using IR sensor which is mounted on the stepper motor which will rotate whole 360 degrees for detecting objects.

## 1.2 OBJECTIVES

In present experimental program the performance of IR radar with combination of stepper motor is used to increase the efficiency of the object detection technique. The experimental program is planned to improve the object detection system also to study the following objectives through which we can improve the performance.

1. To study the properties of Radar.
2. To evaluate the range between the object and radar IR sensor is used.
3. To find out actual distance PIC controller is used which also increases the feasibility of radar.

## 2. WORKING PRINCIPLE

Generally, the distance can be measured using pulse echo and phase measurement method. Here, the distance can be measured using pulse echo method. The IR sensor transmit a signal to the object then receive echo signal from the object and produces output signal whose time period is proportional to distance of object, for that purpose we consider the velocity of light and frequency of signal. Also, we have used the stepper motor which gives 10 degrees of rotation for each step throughout 360 degrees. As the target detects our system will display the distance and angle on the LCD screen. Buzzer will turn on after each recognition of target.

### 2.1 Material required

#### Hardware:

1. PIC 18F877A CONTROLLER
2. IR Sensor
3. Stepper Motor
4. Connecting Wires
5. Power Supply
6. LCD 16\*2
7. Buzzer

#### Software:

1. MicroC
2. Proteus8

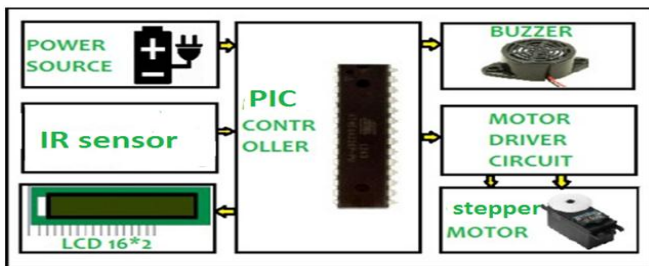

Fig -1: Block Diagram

The above block diagram shows the circuitry of our project. Here, we have used PIC microcontroller as a controller. For detecting the object IR sensor has been used which is also connected to the PIC controller. The sensor has been mounted on the stepper motor for continuous rotation, when as object is detected first then the buzzer will start buzzing and then the LCD display will shows its distance from the sensor.

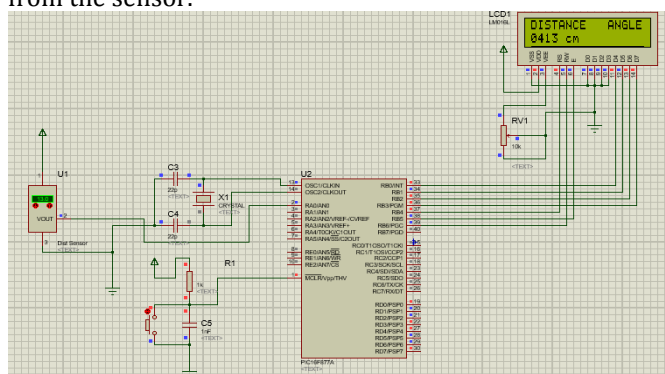

Fig-2: Simulation diagram

### 3. CONCLUSION-

In this paper low cost, low power and efficient detection and access control system is presented. A proof of concept system was designed and successfully implemented with one friend module. A result is successfully displayed on LCD display.

### REFERENCES

1. <https://netmaxtech.com/why-pic-is-important/>
2. <https://embetronicx.com/tutorials/microcontrollers/pic16f877a/ir-sensor-interfacing-with-pic16f877a/>
3. <https://www.electronicshub.org/ir-sensor/>
4. <https://www.jameco.com/jameco/workshop/howitworks/how-servo-motors-work.html>
5. <https://components101.com/pic16f877a-pin-diagram-description-features-datasheet>
6. <https://components101.com/stepper-motor-driver-ic-uln2003-pinout-datasheet>
7. <http://ethesis.nitrkl.ac.in/4836/1/211CS1049.pdf>