

Design of Slot Loaded Patch Antenna and Circular Patch Antenna Using 5G Frequency Range

Ramya Shree R¹, Priyanka B², Ashok P³

¹Student, Department of ECE, PSVPEC

²Student, Department of ECE, PSVPEC

³Professor, Department of ECE, PSVPEC, Tamil Nadu, INDIA

Abstract - This paper describes the 5G antenna design and its specifications. The frequency limit allocated to India for 5G implementation is named as lower and mid frequency ranges from 3.4 to 3.9 GHz and with this frequency range various types of 5G antenna is designed with all its required parameters. High speed Data rate and Efficiency is achieved in 5G by using Massive MIMO technique. Massive Multiple Inputs and Multiple Output can be further developed in future based on their requirements after the 5G antenna is fabricated. 5G Communication aims to improving energy efficiency without compromising on user experience. Massive MIMO and Beam forming important techniques for 5G wireless communication, attracted a great deal of research. Architecture of massive MIMO systems developed by designing large number of 5G patch antennas and they are configured in a single panel for future implementation. 5G antennas designed using microstrip patch in three types - Micro strip patch antenna, Circular patch antenna, Slot loaded patch antenna.

Key Words: 5G Antenna Design, Microstrip Patch Antenna, Circular Patch Antenna, Slot Loaded Patch Antenna, Antenna Parameters.

1. INTRODUCTION

In today's world 4G technology has getting lost its existence as 5G enters into the communication world. To develop 5G and its applications 5G antenna design has a major role for developing it. In today's world there are various types of antenna design but for 5g antenna it can be developed in the form of slot loaded patch antenna design and circular patch antenna design.

The design for choosing the antenna type is important because it can be able to use it over the space craft application and mobile communication. The circular patch antenna is popular for portable wireless system because of their light weight, low cost, low volume, easily manufacturable. The Circular patch antenna that require dielectric substrate over the radiating element to provide protection from heat, rain, physical damages.

The slot loaded patch antenna is designed for the frequency range of 300MHz to 24GHz. it is popular for its easy cutting and can be mounted on any type of surface. The

polarization of slot is linear. it is generally used in high performance aircraft, space craft, satellite, and missile applications, where size, cost, weight, performance, ease of installation etc. it can also be used to develop government and commercial applications such as mobile and radio wireless applications.

This paper mainly consist of the antenna design of both the circular patch antenna and slot loaded patch antenna design which details the developing such antennas for further applications such as mobile and space craft applications.

2. DESIGN OF 5G ANTENNA

Since the types of patch antennas are designed they follow the common procedure. The common procedure for designing such antennas are as follows:

- Specify W, L and the cut-off frequencies namely f_r , ϵ_r and determine the height of the substrate as h.
- For an efficient radiator, a practical width that leads to good radiation efficiencies is given by the equation [1] and as follows,

$$W = \frac{v_0}{2f_r} \sqrt{\frac{2}{\epsilon_r + 1}} \quad [1]$$

- Where v_0 = free space velocity of light
- Determine the effective dielectric constant of the microstrip patch antenna using [2].
- Determine the extension of ΔL using the [3] formula.

$$\epsilon_{r_{eff}} = \frac{\epsilon_r + 1}{2} + \frac{\epsilon_r - 1}{2} \left[1 + 12 \frac{h}{w} \right]^{-1/2} \quad [2]$$

$$\frac{\Delta L}{h} = 0.412 \frac{(\epsilon_{r_{eff}} + 0.3) \left(\frac{W}{h} + 0.264 \right)}{(\epsilon_{r_{eff}} - 0.258) \left(\frac{W}{h} + 0.8 \right)} \quad [3]$$

- The effective length of the patch is given by the equation [4] and is given by,

$$L_{eff} = L - 2\Delta L \quad [4]$$

- These are the equations used for designing the patch antennas.

3. MICROSTRIP PATCH ANTENNA DESIGN

The microstrip patch antenna is designed for the following specification and also follows the above mentioned procedure. Table -1 describes the following parameters are used to design the microstrip patch antenna.

Table -1: Parameters of Microstrip Patch Antenna Design

Parameter	Values
F	3.46GHz
h _s	1.6mm
W	36.11mm
L	27.88mm
F _i	4.8
W _f	2.932
G _{pf}	1
L _g	2*L
W _g	2*W
H _f	0.035

The microstrip patch antenna is designed based on the above parameters with the frequency of about 3.5GHz and is shown in fig-1 as follows:

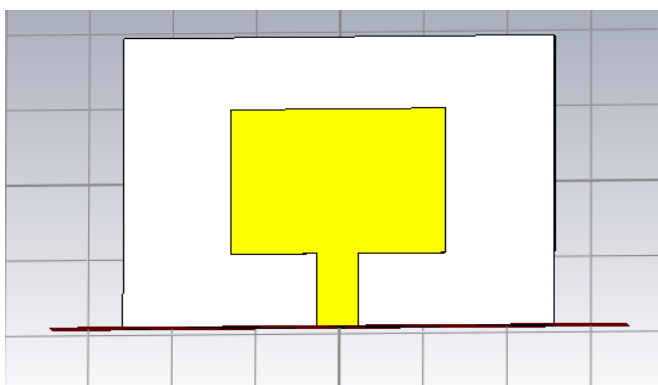

Fig -1: Designed Microstrip patch antenna

4. CIRCULAR PATCH ANTENNA

The circular patch antenna is designed for the following specification and also follows the above mentioned

procedure. Table -2 describes the following parameters are used to design the circular patch antenna.

Table -2: Parameters of Circular Patch Antenna Design

Parameters	Values
L _g	6mm
W _g	6mm
h _g	0.035mm
h _s	0.8mm
R _{patch}	1.5mm
W _{ef}	0.1mm
l _{ef}	3mm

The circular patch antenna is designed based on the above parameters with the frequency of about 4 GHz and is shown in fig-2 as follows:

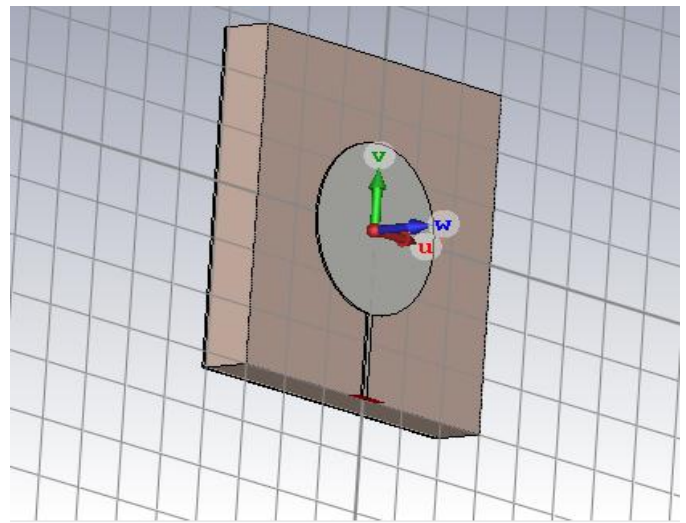

Fig -2: Designed Circular Patch Antenna

4. SLOT LOADED PATCH ANTENNA

The slot loaded patch antenna is designed for the following specification and also follows the above mentioned procedure. Table -3 describes the following parameters are used to design the slot loaded patch antenna.

Any number of slots can be created in the slot loaded patch antenna as per the applications requirement. In the designed slot loaded patch antenna, the power loss is minimum when compared with the circular patch antenna. In the designed slot loaded patch antenna there are 4 slots used

for the development of spacecraft applications, mobile communications, low profile antennas.

Table -3: Parameters of Slot Loaded Patch Antenna Design

Parameters	Values
λ	56.53mm
L	28.265mm
W	28.265mm
T	0.1mm
H	0.8mm
X	4.06625mm

The slot loaded patch antenna is designed based on the above parameters and is shown in fig-3 as follows:

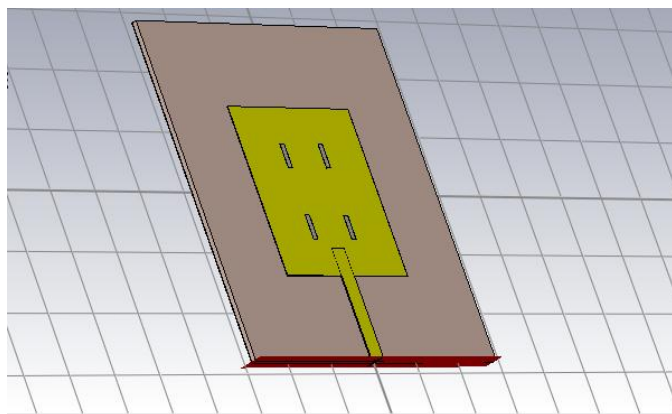

Fig -3: Designed Slot Loaded patch Antenna

5. ANALYSIS AND RESULTS

Two types of antennas are designed with the above parameters. They are circular patch antenna and slot loaded patch antenna designed on the frequency range allocated for 5G for India. The various output parameters for these two antennas are listed below with its corresponding figures in 3D as follows with various pictorial and graphical representation as shown below:

5.1 Result of Circular Patch Antenna Design

The following list of parameters achieved by the circular patch antenna design to prove its efficient working under the frequency range of 3.5GHz of 5G. The attained parameters are [i]S-Parameter [ii]VSWR [iii]Efficiency[iv]Far Field Distance in 3D [v]Far Field Directivity in polar form [vi]Impedance [vi]Admittance.

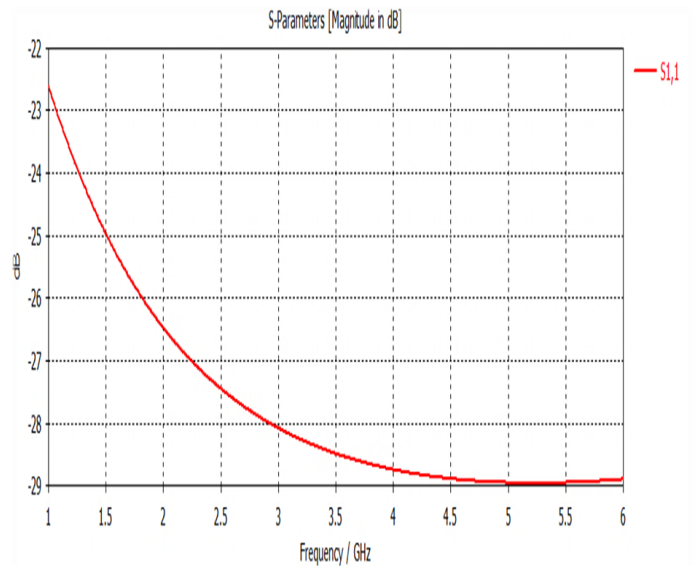

[i]

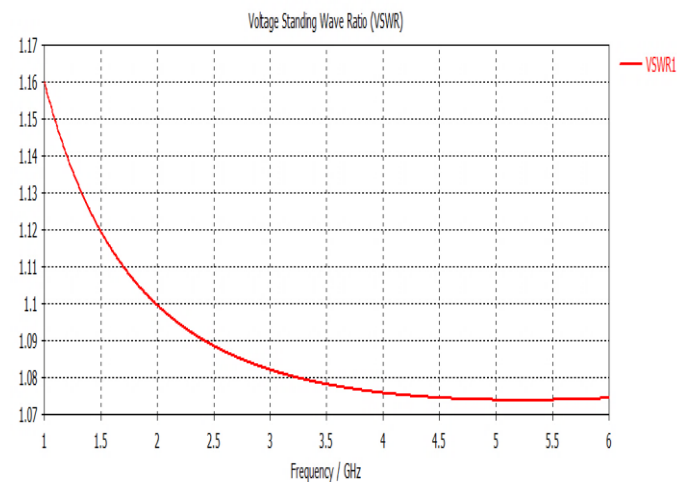

[ii]

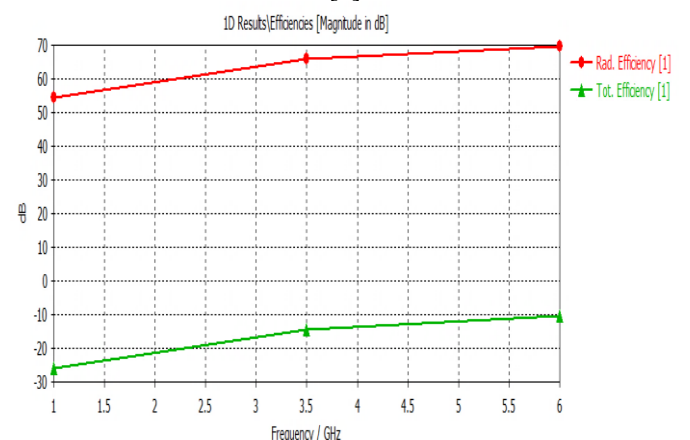

[iii]

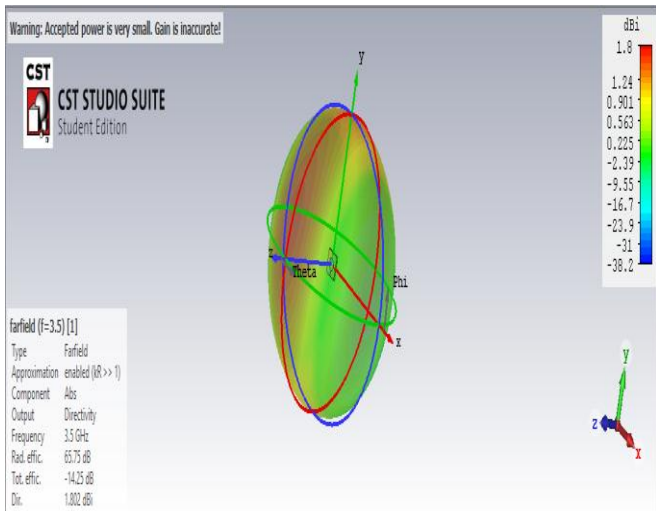

[iv]

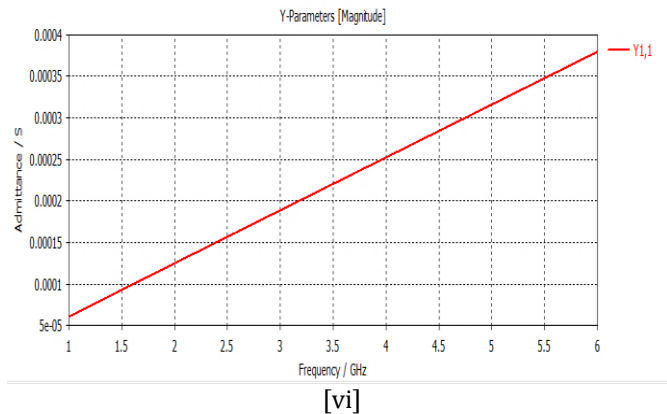

5.2 Result of Slot Loaded Patch Antenna Design

The following list of parameters achieved by the circular patch antenna design to prove its efficient working under the frequency range of 4GHz of 5G. The attained parameters are [i]S-Parameters [ii]VSWR [iii]Efficiency [iv]Far Field Distance in 3 [v]Far Field Directivity in polar form [vi]Impedance [vi]Admittance.

The slot loaded patch antenna output parameters shown below represents the features of slot loaded patch antenna with high radiated power and also with minimum power loss in compared with the circular patch antenna which has high efficiency.

Thus the following graphs shows various parameters attained from the design of slot loaded patch antenna in the following output results as shown below.

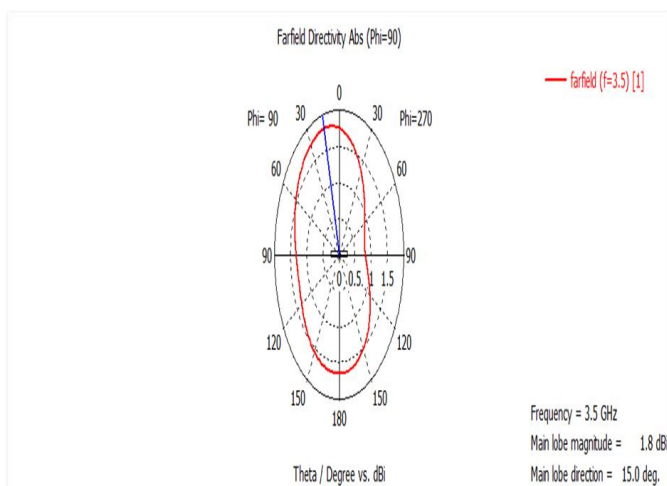

[v]

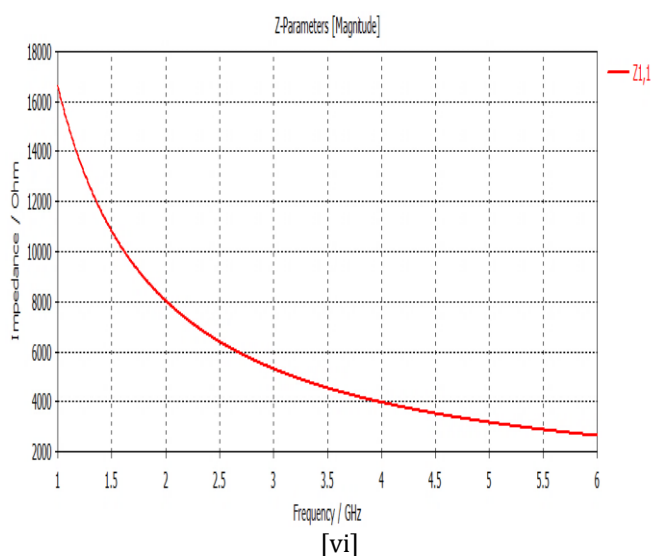

[vi]

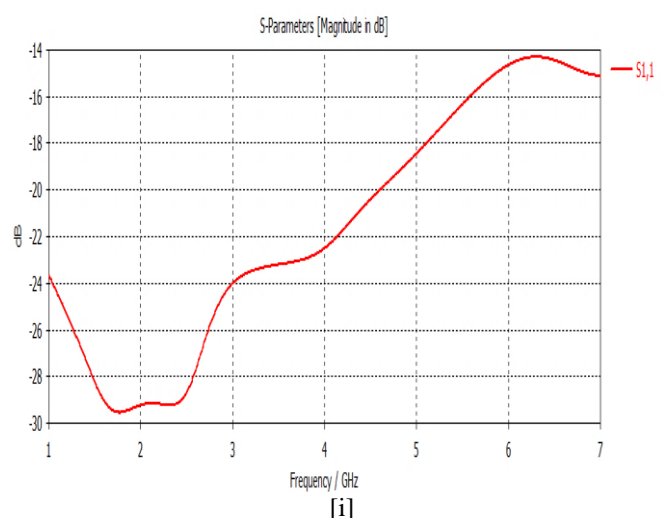

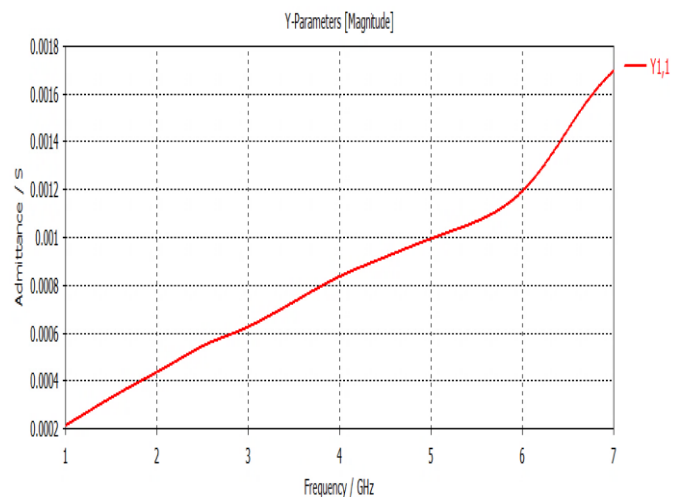
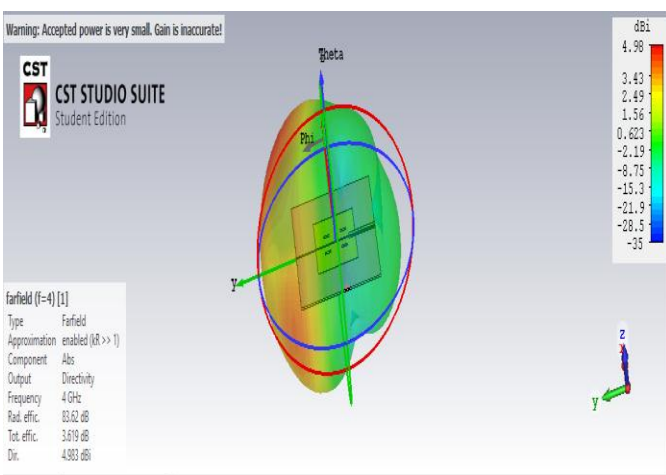
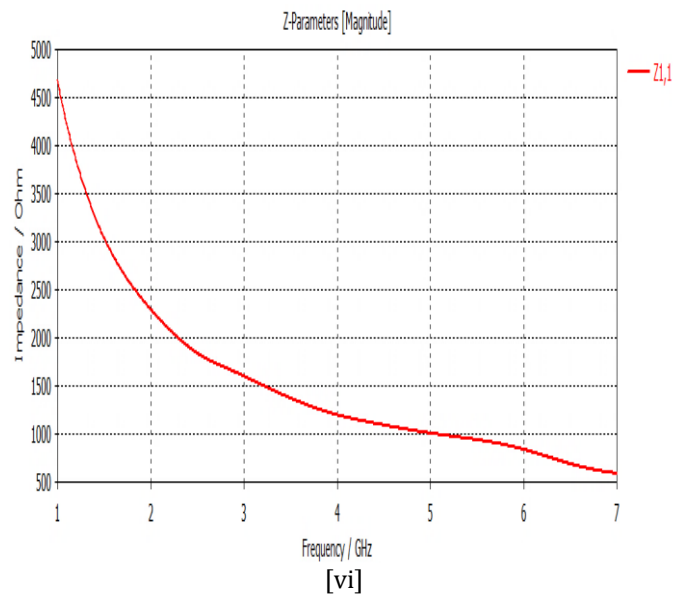
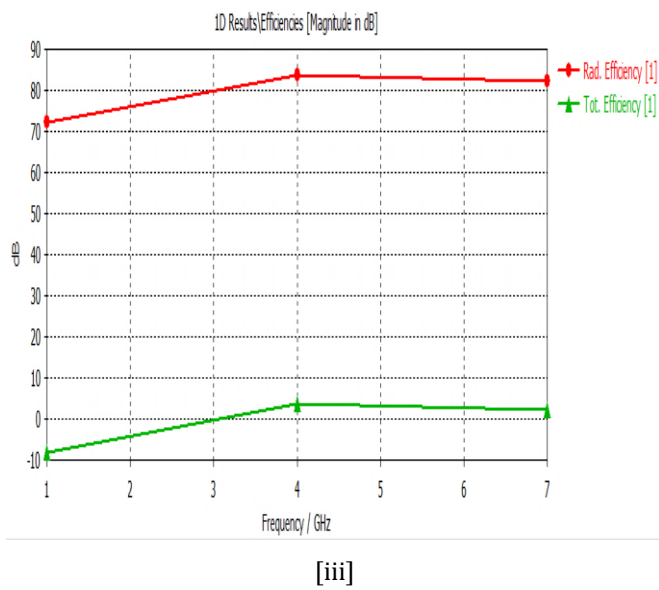
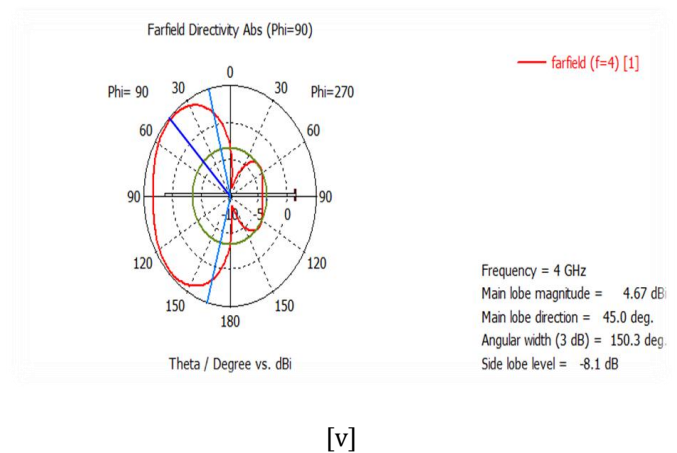
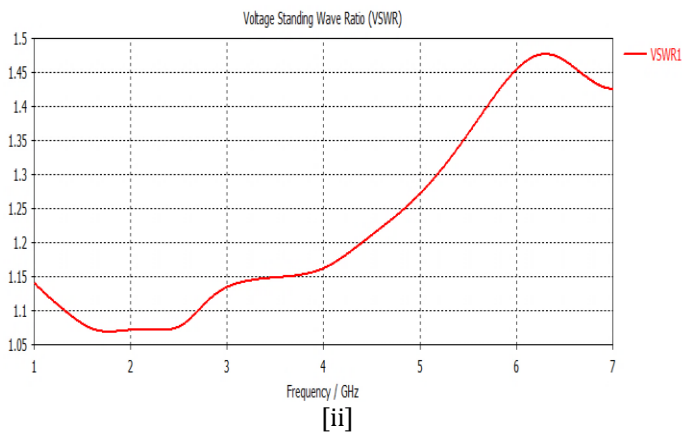

6. CONCLUSIONS

The final conclusion of the project is designing different types of antennas with 5G frequency (mid frequency range 3.4 to 3.9 GHz) allocated to India, used for mobile communication. Here Micro strip patch antenna has been designed as reference it has been modified in to different types as follows. They are Circular patch antenna of frequency range is of 3.5GHz and Slot loaded patch antenna of frequency range is of 4 GHz. This antenna design can be further deployed in future research and development process for future enhancement. Then these antennas can be fabricated and constructed to Massive MIMO antenna by implementing them in single panel.

REFERENCES

- [1] M. Abirami, and Alhothaily, "A review of patch antenna design for 5G in wireless communication," IEEE Wireless Communication, 2018.
- [2] A. Afif osserain, Jose F. Monserrat, "5G Mobile and Wireless Communication," 2017.
- [3] Qia Wang Ning Mu, Ling Li Wang "5G MIMO Conformal Microstrip Antenna Design," IEEE Wireless Communication and Mobile, 2016.
- [4] Wonbin Hong, Kwang-Hyun Baek, Seungtae Ko, "MillimeterWave 5G Antennas for Smartphones: Overview and Experimental Demonstration," IEEE Wireless Communication, 2016.
- [5] Yassine Jandi, Fatima Gharnati, Ahmed Oulad, "Design of a compact dual Band Patch Antenna for 5G Applications," IEEE Journals on Wireless Communications, 2016.

BIOGRAPHIES

1. Ramya Shree.R, UG Student from PSVPEC pursuing ECE. Her area of interest include Antennas,Wireless Commuication.
2. Priyanka. B, UG Student from PSVPEC pursuing ECE. Her area of interest include Antennas,Wireless Commuication.
3. Ashok P, Assistant Professor from PSVPEC has guided this project . His area of interest include Antennas,Wireless Commuication.