

Organ Printing For Surgical Planning Using Additive Manufacturing Machine From Patient Medical Imaging Data

Sagar R Ganthade¹, Prof. Vikram Gawali²

¹UG Student ²Assistant Professor

^{1,2}Department of Electronics and Telecommunication Engineering, Government College of Engineering Chandrapur, Maharashtra, India

Abstract -additive manufacturing for 3d printing is low cost and easily available platform for the medical use, this additive manufacturing machine is very adaptive in nature once a designer's create's a machine then they can use it for printing any complex 3d body organ's on which surgeon

Makes the planning on that organ's just before a surgery. We feed the patient medical imaging data of CT & MRI to the 3d printing machine to create exact replicas organ's from original organ's this can enhance the surgeon's skill.

1. INTRODUCTION

Additive manufacturing is straight forward, an object is created by starting with nothing and adding material layer at a time until you have a completed object there are many natural example of the process for example making a brick wall

There are three categories of additive manufacturing

- 1.1 Selective binding
- 1.2 Selective solidification
- 1.3 Selective deposition

1.1 Selective binding

Selective binding technologies make 3d printed object from a powder (metal and gypsum are common material) by applying binding agent or heat to fuse the powder's practical's together, an example is SLS

Selective laser sintering in which a laser is used to fuse one layer of powdered material at a time the first layer is fused to a platform acts as a supporting medium for the print, so that very complex and delicate print can be created

1.2 Selective solidification

Selective solidification makes a solid object from a vat of liquid by selectively applying energy to solidify the liquid layer at a time. Again typically a first layer is created on some sort of build platform, which then moves down into the liquid or in some cases, a build platforms pull up out of the liquid. One example is stereo lithography SLA, which uses UV light projection DLP imager, to harden a whole layer at a time

1.3 Selective deposition

Selective deposition technique only place material where you want it, the filament based printers by melting a filament and then placing the melted plastic to create an object precisely.

Which technologies have been used depends on several things our budget, the model's complexity and finest details but here we used a selective deposition technique.

1. LITERATURE SURVEY

the main focus of this project to improve the anatomical & physiological knowledge about complex human organs for medical student's as well as for the surgeon to stimulates the operation procedure on dummy organ's printed by this project. This project is inspired from the 3d bone printer by using the patient medical scanned image data and processing on them we can print the exact replicate organ's.

2. DESIGN CONSTRUCT & OPERATION

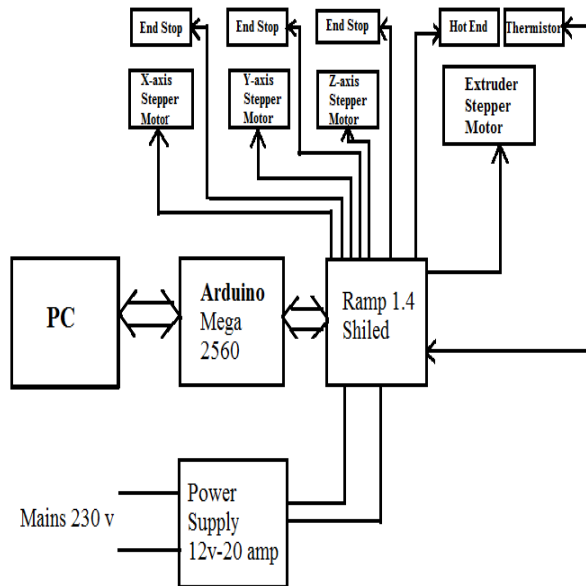

Fig-1: Block diagram

the structure of this machine is made out of aluminum rectangular block's this machine uses the 3 axes for controlling this axes we use the smooth rods for the smooth controlling on it on that friction's and also threaded rod is needed for the z axis controlling. The X & Z axes move the extruder carriage. While the Y axis moves the bed .For the transmission of X & Y axis we used the GT2 timing belt along that GT2 pulley which can be hooked up we the stepper motor shaft the Z axis using a pair of MY threaded rods coupled with two synchronized stepper motor here we used Neema17 stepper motor .For controlling the system we used the aurdino mega 2560 microcontroller and a RAMPS Shield with aurdino .The desktop computer will sends the installation towards the microcontroller then this Atmega 2560 will decodes this instruction and gives the controlling signal towards MOSFET works as a switching element for hotendby just simply turn ON the power register for melting a filament & stepper motor's to power the overall electronics component we used 12 V DC 20 Amps power supply .

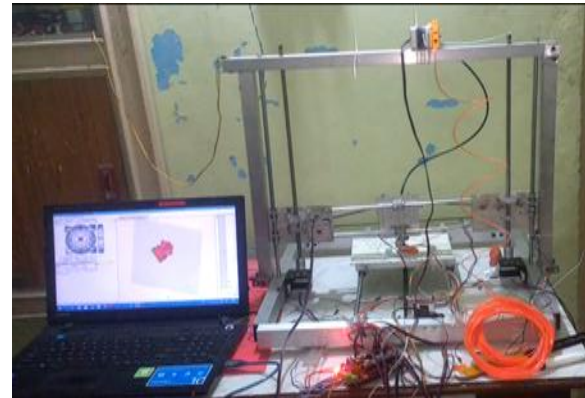

Fig-2: Model of Additive Manufacturing Machine

3. PRINTING ORGANS MODELS

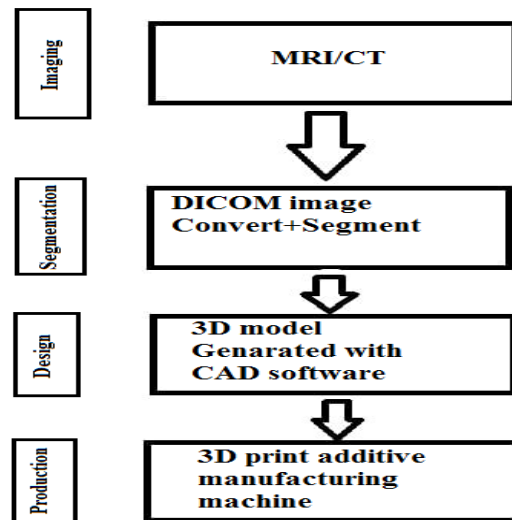

Fig-3: Flowchart for converting medical images into 3D images

The printing of organ's model's summarized in three stage Image acquisition, Image Segmentation, 3d printing.

4.1 Image acquisition

Image acquisition is the first step the most popular medical imaging method for scanning are CT (Computed tomography) and MRI (magnetic resonance imaging) both CT & MRI consisting a three Sets of grayscale images. Having a two divisional layer & the format of this scene image is in DICOM

4.2 Image Segmentation

The main used of this step to reduce the complexity of the original image after the radiologist getting the DICOM they must obtain the regions of interest ROI to be as 3d printable object. The process of identifying and separating tissues and other regions of interest is called segmentation. after Segmentation is completed convert Segmented objects into a file type that additive manufacturing machine can use this file type is typically an STL file format for conversion of STL format we used the 3d slicer software which can create a 3d mesh from DICOM THE 3D slicer is open source image visualization software package

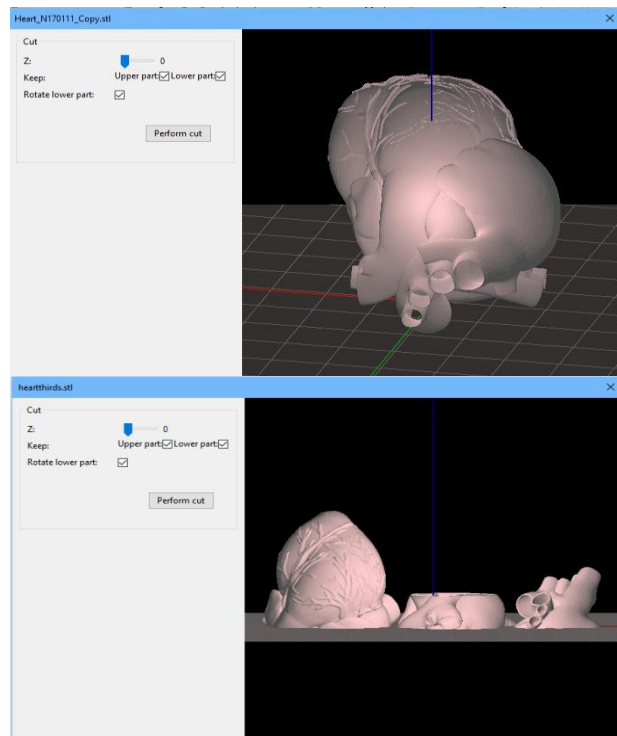

Fig-4: Screenshot of the segmented human heart

4.3 3D printing

Once G-code file is ready, it can be exported and send to a microcontroller for 3d printing fabrication

In order to create the G Code from the organ model's a software known as a "Slicer" needed to be used in this case" Slic3r"software has been used for conversion of STL to G-Code

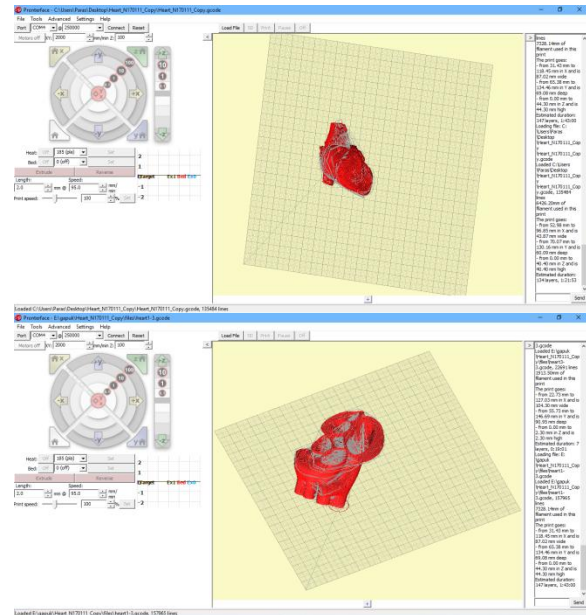

Fig-5: Screenshot of G-code Realization human heart

4. CONCLUSION

thus we can conclude that the surgeon can used the MRI and CT Scan of patient's organ's and can obtain a 3d printed organ for pre operation study purpose

This technique can also be used for medical student to study about different organ's in details

REFERENCES

Proceeding paper & Books

[1] Popescu, A. T., Stan, O., & Miclea, L. (2014). 3D printing bone models extracted from medical imaging data. 2014 IEEE International Conference on Automation, Quality and Testing, Robotics. doi:10.1109/aqtr.2014.6857890.

[2]Mastering3d printing Modeling, Printing, Prototyping with Rep-Rap 3d Printers by Joan Horvath.