

## RESIDENTIAL HYDRO POWER GENERATION

Tandale Vaibhav Santoshrao<sup>1</sup>, Mhetre Tanmay Sujitkumar<sup>2</sup>, Survase Sumeet Ramchandra<sup>3</sup>,  
Patil Pravin Raghuvir<sup>4</sup>,

Mr. Bidve Mangesh Angadrao<sup>5</sup>, Mr. Devshette Ashish Rajkumar<sup>6</sup>

<sup>1,2,3,4</sup> Diploma Students, Department Of Mechanical Engineering, Vishweshwarayya Abhyantriki Padvika  
Mahavidyalay, Almala, Latur, Maharashtra, India

<sup>5</sup> Head Of Department, Mechanical Engineering Department, Vishweshwarayya Abhyantriki Padvika  
Mahavidyalay, Almala, Latur, Maharashtra, India

<sup>6</sup> Lecturer, Department Of Mechanical Engineering, Vishweshwarayya Abhyantriki Padvika  
Mahavidyalay, Almala, Latur, Maharashtra, India

\*\*\*

**Abstract** - In this paper an attempt is made to construct a model of residential hydro power generation for running the generator and use of battery to light up the houses which is common to rural folks. The difficulty of getting the fuel and the cost of fuel are the main problems. Use of other alternative renewable energy such as solar photovoltaic modules, which is available for a number of hours per day, is very costly. It is required to find suitable option to provide cheap and reliable option. While large hydropower provides electrical power for industry and domestic use, small-scale hydro is making some contributions toward providing this basic need to remote and off-grid areas especially in developing countries.

This paper is focusing on hydro-power an application which does not require complex design set up. It is cost effective, environmentally friendly and the turbine can be manufactured locally. Water flow in the domestic pipes has kinetic energy that potential to generate electricity for energy storage purposes in addition to the routine activities such as laundry, cook and bathe. The inherent water pressure and flow inside the pipe from utility's main tank that used for those usual activities is also used to rotate small scale hydro turbine to drive a generator for electrical power generation. Hence, this project is conducted to develop a small scale hydro generation system using consuming water distributed to houses as an alternative electrical energy source for residential use.

**Key Words:** Generator, Hydro power Generation System, Small-scale hydropower, turbine, rural electrification, Renewable Energy

### 1. INTRODUCTION

Residential hydro power generation is an application based project model which works on principle of hydro electricity generation methods with maximum electric output of 3 KW.

It is also called PICO hydro power generator.

Hydropower can bring low-cost electricity to isolated communities without polluting the air or water. Furthermore, hydropower is a proven technology; people have been obtaining energy from falling water. It is also a versatile power source. AC electricity can be produced enabling standard electrical appliances to be used. Common examples of devices which can be powered by hydropower are light bulbs, radio and televisions, and other electric appliances.

It allows electricity generation simply and at no fuel cost. The growing high demand in electrical energy is forcing man to search for different available energy resources. The equipment used in hydroelectricity generations specialized with its small and compact design, so that it could be installed in a small area very easily. The main benefit of hydroelectric power generation is that it has a lower cost per kilowatt compared to that of solar or wind power.

The hydropower plant can be classified according to the size of electrical power it produces as shown in Table 1.1.

Hydro power	Type/Class
> 10 MW	Large
< 10 MW	Small
< 1 MW	Mini

< 100 KW	Micro
< 5 KW	Pico

**Table 1.1:** Classification of Hydro-Power Plant

Pico-hydro is a term used to define the smallest systems, casing hydroelectric power generation under 5kW. Depending on its size, a pico-hydro power system may provide a small, remote community with adequate electricity.

Type	Capacity
High Head	100 m and above
Medium Head	30 – 100 m
Low Head	2 – 30 m

**Table 1.2:** - Classification of Hydro plant based on head

## 2. RESEDENTIAL HYDRO POWER GENERATION

Micro generation or residential hydro power generation is feasible option for the average village/ town home. Under the technology of “Home Water-Tank Pico Hydro Power Generator Distributed Generation for Smart Home” here trying to generate power from low hydro energy to generate clean and green electric power for every home at remote location. Pico hydro is a hydroelectric power generation of

under 5 kW. It is useful to fulfill need of electricity for individual home that require only a small amount of electricity.

setup typically is run-of-stream, meaning that a reservoir of water is not created, only a small weir is common, pipes divert some of the flow, drop this down a gradient, and through the turbine before being exhausted back to the reservoir again. Like other hydroelectric and renewable source power generation, pollution and consumption of fossil fuels is reduced, though there is still typically an environmental cost to the manufacture of the generator and distribution methods. Home & Village/Town Water storage tank can be used to create head to drive Pico Hydro power

Generator. Generator (1kW) enough for cooking, home lightning, Electric fencing and many at rural and urban applications. Simple water turbine designed to work with quantity of water flow rather than the Head. Such generator can be used where no enough head at the site.

There are many factors that determine the feasibility and achievability of the system. This includes:

- i. The amount of power available from the water flow inside the pipelines. This depends on the water pressure, amount of water available and friction losses in the pipelines.
- ii. The turbine type and availability of required generator type and capacity.
- iii. The types and capacity of electrical loads to be supplied by the Pico-hydro system.
- iv. The cost of developing the project and operating the system.

### A. Power Estimation

This system works on the principle of relation between potential of input and output power of hydro energy.

$$P_{in} = H \cdot Q \cdot g \tag{1}$$

$$P_{out} = H \cdot Q \cdot g \cdot \eta \tag{2}$$

Where  $P_{in}$  = Input Power (Hydro Power)

$P_{out}$  = Output Power (generator power)

H = head (meter)

Q = water flow rate (liter/second)

g = acceleration due to gravity (9.81 m/s<sup>2</sup>)

$\eta$  = efficiency

Based on the equation (1) and (2), both head and water flow rate are very important parameters in hydropower system. Head is a measure of falling water at turbine, i.e. vertical distance from the top of the penstock to the turbine at the bottom. Conversely, water flow rate is the amount of water flows within one second. Normally, water flow available is more than needed since the flows for Pico-hydro are small. Thus, it is important to measure the head carefully because the greater head, the greater power and the higher speed of the turbine rotation

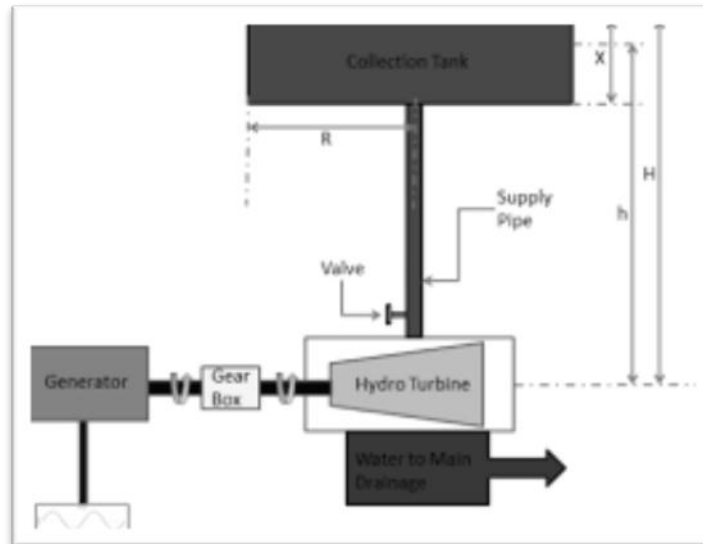

Fig 2.1.1: Power Flow of Hydro Power Generation

**B. Head Measurement:**

There are various methods for head measurement. Gross head is the vertical distance between the top of the penstock and the point where the water hits the turbine. Water is stored in collection tank and it flows through pipelines onto the runner buckets of hydraulic turbine.

The speed of rotation of turbine and power generation capacity depend on the available head of water. Also during the flow of water various head losses take place like major and minor losses due to friction, bend, and sudden area change of pipe. Gross head can be used to estimate power availability and determine general feasibility, but net head is used to calculate the actual power available.

The available head for setup is determined by using relation of

$$H = 0.704 * P$$

Where H = head available (meter)

P = water pressure (Psi)

The water pressure represents the net head of the system that useful to calculate the actual power available.

**C. Hydraulic Turbine:**

The hydraulic turbine model is constructed for our project setup by using a runner wheel and curved cups are attached on its periphery at regular distance.

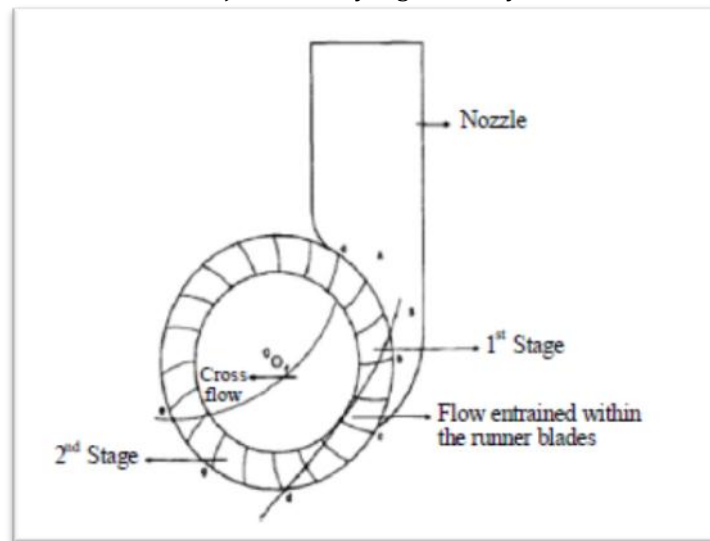

**Fig 2.1.2: Hydraulic Turbine runner model**

The turbine with 6 cups fabricated from polyvinyl chloride (PVC). is used for the proposed system.

Reaction turbine is fully immersed in water and is enclosed in a pressure casing. The runner or rotating element and casing are carefully engineered so that the clearance between them is minimized. In contrast, impulse turbine can operate in air and works with high-speed jet of water.

**Pelton Turbine:** Pelton turbines are suitable to high head, low flow applications. It can be outfitted with one, two, or more nozzles for higher output. Typically, when using this type of turbine, water is piped down a hillside so that at the lower end of the pipe, it emerges from a narrow nozzle as a jet with very high velocity to the turbine blades.



**Fig 2.1.3: Working Of cross flow turbine**

As the fluid passes through the turbine, the fluid transfers energy to the turbine blades, creating angular momentum that rotates a central shaft and generates electricity.

**D. Flow rate:**

The flow rate water flowing through pipelines from water tank to turbine depend on the elevation of tank above the ground surface. The relation between flow rate and speed of turbine is given by

$$Q = A \cdot V$$

The flow rate of the distributed water is diverted into a bucket or barrel and the time it takes for the container to fill is recorded. The volume of the container is known and the flow rate is simply obtained by dividing this volume by the filling time. For example, the flow rate of water that filled 20 liters bucket within one minute is 20 liters per minute or 0.333 l/s. This is repeated several times to give more consistent and accurate measurement.

#### D. Pipeline System and Friction Loss:

Piping system is used to carry water to a turbine. This is commonly termed as penstock which consists of pipe from the reservoir or fore bay tank to the turbine and valve or gate that controls the rate of water flow.

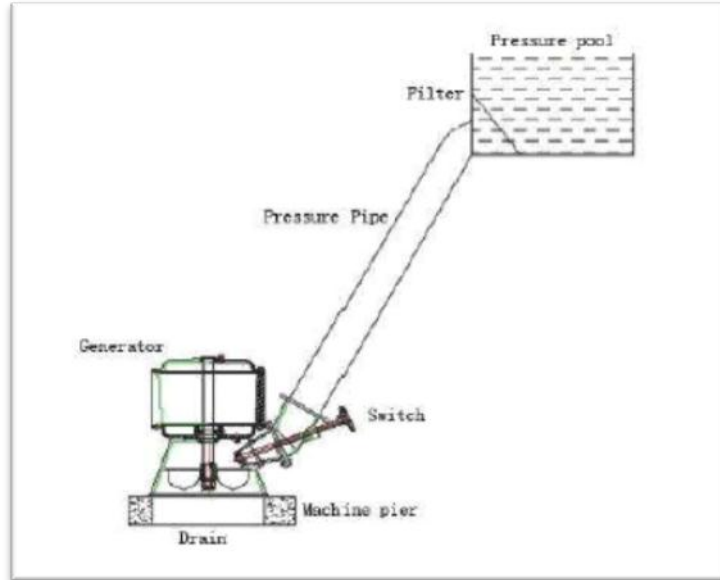

Fig 2.1.4: Part details of project model

#### D. DC GENERATOR:

A permanent magnet DC generator is preferred for generating electricity out of the mechanical power produced in a hydro system. DC generator could provide high currents at even minimum voltage required for charging of the battery and operation of direct current loads. They are much cheaper and are small in size too.



Fig 2.1.4: DC generator assembly

#### E. BATTERY CHARGER

Batteries are used for storing of electrical energy and reused when necessary. The generator output is made connected to the charging circuits for energy storage. When charged a maximum load current is limited to 1.5 A, Ni-Cad battery is preferred for the hydro system. Lead acid battery could be also used if necessary.

### 3. TECHNOLOGY AND WORKING

Residential Hydro-power generation is an application based project model. It consists of different parts like

- Hydraulic Turbine Model
- Casing to turbine
- Water storage tank

- Pipelines
- Nozzle
- DC generator
- 12 V battery
- Bearings
- Shaft
- Water sump

All above parts are arranged in a required manner to construct a project model.

Water is stored in storage tank in large quantity at the roof of buildings or at appropriate elevation above earth surface. This provides the potential energy in stored water.

When water is allowed to freely flow through pipe then potential energy is converted into kinetic energy.

This water flow strikes on the buckets of turbine runner through nozzle.

Due to pressure head and high flow rate the turbine rotates with high speed so power is produced.

This rotation of turbine is transferred to electric generator by the shaft and bearings arrangement.

Generator converts mechanical energy into electric energy and get stored into battery.

The blade is most significant component of micro wind turbines which extracted Kinetic Energy from wind and convert into electricity through generators. Production of Kinetic energy is influenced by Aerodynamic shape of micro wind turbines.

Micro Hydro Turbine is widely used in hydro power plants with the high head from 2m to 200m. Design water flow from 0.1m<sup>3</sup>/S to 3m<sup>3</sup>/S. Runner diameter from 0.8cm to

1meter. Capacity from 5KW to 100KW for one single turbine.

### 3.1 Structure of Pelton Wheel Turbine:

- The Pelton wheel is a universal component used in hydroelectric power production. The main parts of the Pelton wheel are runner, spray pipe, baffle plate, spiral casting, diversion plate.
- The main material requirements are high strength, abrasion resistance, casting suitability and ability to withstand extensive use in water. Materials generally used are Aluminum, Copper Alloys, Grey Cast Iron, Stainless Steel and Plastic.
- Electricity from waste energy can be used for charging mobile phones in restaurants, coffee shops, hotels or resorts which will have large source of waste water. This can be considered as green engineering as it is recovering waste energy. Apart from charging mobile phones, another application may be to power to small lights on pathways.

### Material Specification :

Base rod dimensions:

Length of base -1000 mm

Breadth of base -500 mm

Height of base -1020 mm

Width of rod -5 mm

Outer casing specification:

Diameter of casing -890 mm

Thickness of casing sheet -1.5 mm

Pelton wheel specification:

Diameter of pelton wheel -700mm

Width of pelton wheel sheet -50mm

Total number of cups attached -12

Motor pump specification:

Power -1 HP

Capacity -8000 LITRES/HOUR

Water inlet - 22 mm

Water outlet -8 mm



**Fig 3.1:** Pelton Wheel Without Bucket



**Fig 3.2:** Pelton Wheel with bucket

### 3.2 Structure of Frame:

Design of the frame is of great importance as it has to be manufactured in order accordingly with the design and scale of the project. The frame should have the capacity to hold the whole project firmly so that it could not fall or break down during the running of water or running of the Pelton wheel during its live operation.



**Fig3.3:** Frame

### 3.3 Nozzle:

Nozzles are used to provide the high velocity jet coming out of the pump to the Pelton wheel. We had made these different sizes of nozzles. The diameters of the nozzles are 20, 25, and 30mm.

### 3.4 Shaft:

To connect the alternator and the shaft, coupling is used. For coupling, one part of the shaft is threaded to join the alternator. We make a key slot on the shaft and the coupling part, which is done in the lathe and the shaper machine so that the rotatory motion of the shaft is being transferred to alternator/generator.

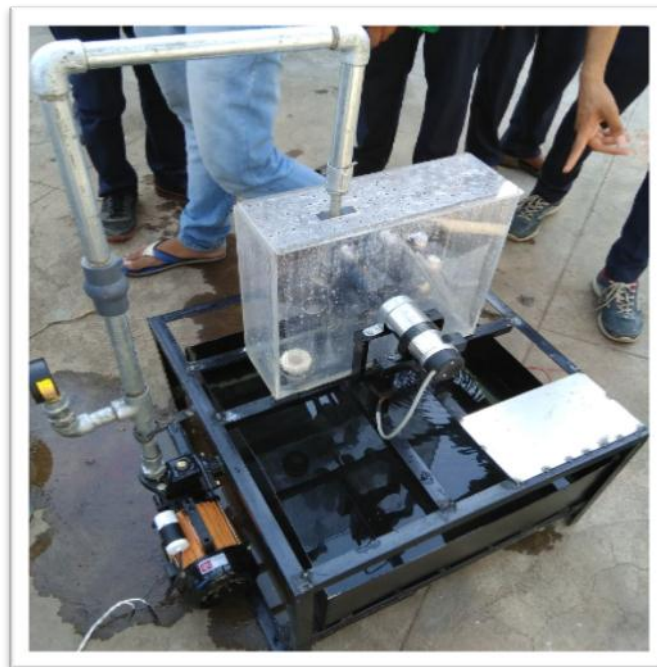



**Fig3.4:** Shaft

#### 4. RESULTS:

After completion of all the required parts, an alternator/generator is fitted to the main shaft of the rotating turbine and a proper cover is made by using sheet metal so that water could not get entered inside the turbine which may cause some problems to the alternator used. As all the required parts are manufactured and fabricated painting is done on the all required parts so that there should not be any rusting problem. Painting also gives an attractive look to the model.



**Fig 4.1:** Final project Model

#### 5. DISCUSSION ON PROJECT MODEL :

- The design and fabricated model have given around 500 rpm when rotated with the help of a pump under the artificial head of 15m. This rpm can be further enhanced by using a higher head resulting in more discharge of water and more jet velocity.
- The Pelton wheel may not rotate after a while or stop rotating if enough RPM is not generated as per the limitations of the Alternator due to partial excitation of the rotor. Partial excitation of the rotor inside the alternator generates opposition force to the rotating shaft. If we can overcome this force, then only current will be generated produced/generated in the alternator.
- If there is manufacturing defect in the alignment of the Pelton wheel, then there will be vibrations to the Pelton wheel which may result in fewer rotations or zero rotations
- The Pelton wheel, shaft and Alternator should be held tightly in the frame so that there must be lesser vibrations as much as possible.
- The design of the nozzle should be such that it could discharge the required amount of water without any failure with a high velocity. This velocity of jet would generate the force on the Pelton wheel will lastly rote the conductor of the Alternator.



## 6. CONCLUSION:

Residential hydro power generation system is to be designed as an alternative energy resource by consuming water from the water tank of residential buildings. This could be a reliable and eco-friendly form of energy, which can be generated to develop small scale hydro generation. This is very versatile power source that could be used to generate AC electricity even at remote places along around the globe.

Hydroelectric power has an important role to play in the future, and provides considerable benefits to an integrated electric system.

## 7. REFERENCES:

- A Textbook of Hydraulic machines- by R.K. Rajput
- Principles of electrical machines- by V.K. Mehta and Rohit Mehta
- [www.ehow.com](http://www.ehow.com)
- [www.google scholar.com](http://www.google scholar.com)
- Ministry of power, Government of India 2010 [www.powermin.nic.in](http://www.powermin.nic.in)
- Renewables 2011 Global Status Reports, page25, Hydropower
- D. Singh, Micro-Hydro-Power, Resource Assessment Handbook, An Initiative of the Asian and Pacific Center for Transfer of Technology, September (2009).